

F9J "	89G7 F-DHC B.	B5A 9#85H9.

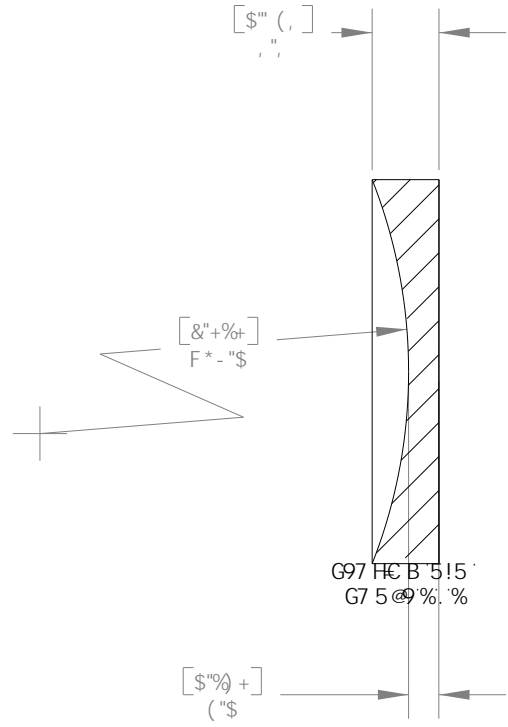
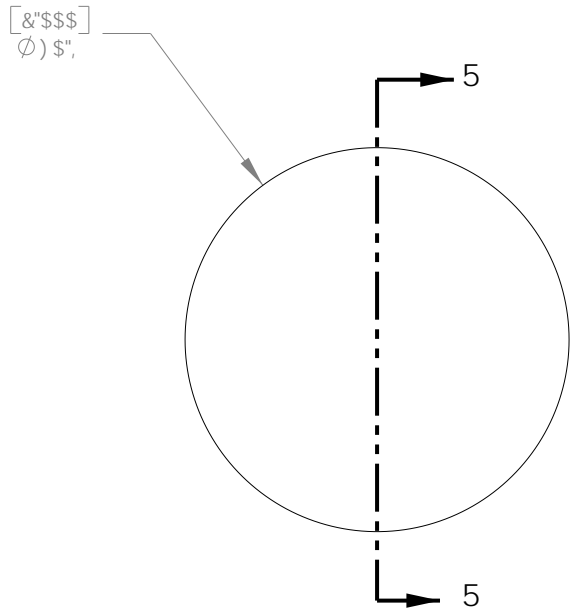

89G7 B K 5J 9@9B; Hk.'**' ba
 G7 F5H7 <#8 ≠ . (\$#&\$
 8-5A 9HDF HC @F5B7 9. Z'\$\$\$a a #!\$"%\$a a
 7 @5F 5D9F5H F9. 2- \$!
 7 9BHF5HC B.' 5F7 'A B"
 5 @5F 7C 5HB; G5F96FC 5865B8 5F'
 7C 5HB; GK Hk FO\$") i C J 9F Hk 99BHF 9F5B; 9'
 5H\$\$-B7 -89B7 9"

7C 5HB; .1 B7C 5H98
 :C7 5 @9B; Hk. !%) '\$\$a a
 657? :C7 5 @9B; Hk. !%) '&"+a a
 b1 %(* '\$\$,

HC @F5B7 9G	B5A 9	85H9
1 B @GGCH: 9FK @9 GD97 ≠ 98.	8F5K B	65; (#& #&\$ \$*
8-A 9BGC BG5F9-B -B7 <9G	9B; 5DDF"	HC (#& #&\$ \$*
@B95F HC @F5B7 9G	A: ; 5DDF"	HC (#& #&\$ \$*
...HK C D@57 9897-A 5@ ±\$'\$%\$	DFC DF-96FM5B8 7CB: -89BH5@	
...H: F99 D@57 9897-A 5@ ±\$'\$%\$)	Hk-9 B: CFA 5HC B 7C BH5-B98 B Hk-6	
5B: 1 @5F. ±' \$H"	8F5K B: 6Hk-9GC @DFC D9F HMC:	
GI F: 57 9: B-G<." &A 7FC -B7 <9G	Hk C F @56Gz-B7 " 5BMF9DFC 8I 7HC B	
D5F 5 @9@CA. '\$\$\$&	B D5FHC F 5G5 K <C @K Hk C I H	
: @5B 9CG '\$\$\$&	Hk-9K F #H9 D9FA 6GC B C:	
GF 5 ≠ <HB 9CG '\$\$\$&	Hk C F @56Gz-B7 " 6DFC <-6+98"	
7C B7 9BHF 7 HM '\$\$\$&		
D9FD9B 8-71 @5F HM '\$\$\$&		
H: F95 8. 7 @5GG&: #H		

Hk C F @56Gz-B7 "		DC '6CL' **
		B9K HC B B>
H# @.		
I J D@5BC 7C B7 5J 9 @9BGZ!%) '\$\$a a X1) \$", a a		
A 5H9F 5@		G#9 F9J "
I J ; F589: I G98 G@7 5		5 5
G7 5 @% %		G<99H% C: %
8K ; " BC "	D5FH BC "	@7 (, *-
') \$+!9\$ %		