

FGA21 InGaAs Photodiode  
 Active Area: 3.14mm<sup>2</sup>  
 Range: 800-1700 nm  
 Cathode Grounded

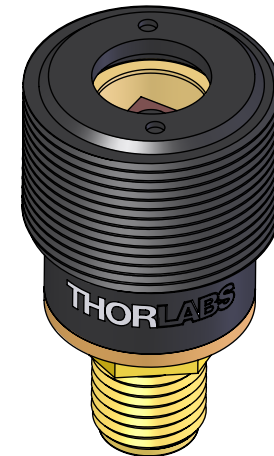
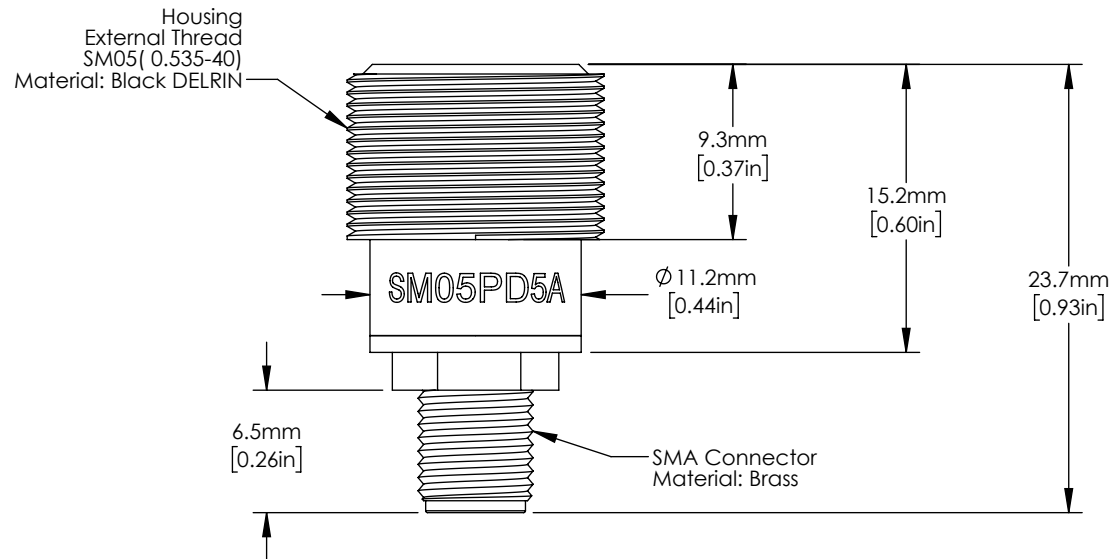
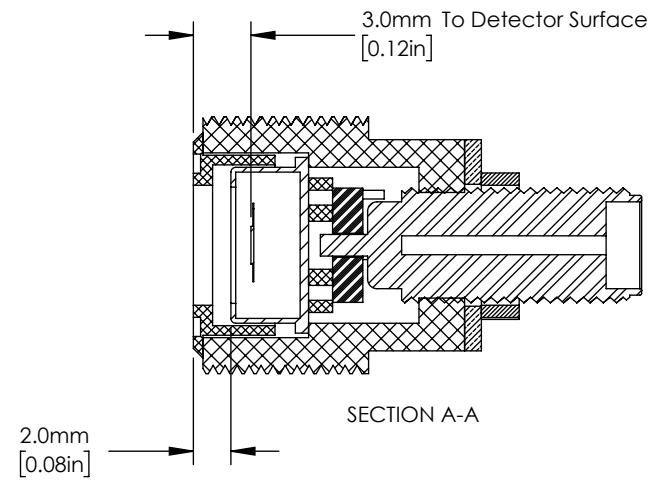
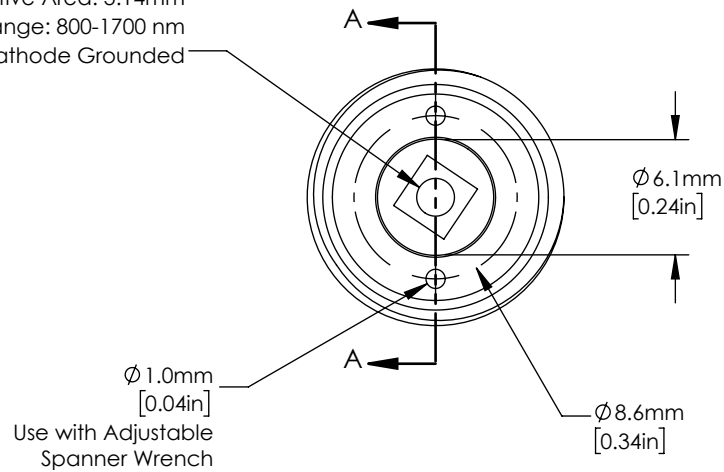

FOR INFORMATION ONLY  
 NOT FOR MANUFACTURING PURPOSES

DRAWING PROJECTION			<b>THORLABS</b> www.thorlabs.com	
NAME	DATE	SM05 Mounted InGaAs-Photodiode		REV
DRAWN	WKC	29/MAR/18	E	
APPROVAL	EC	30/MAR/18	MATERIAL	See Drawing
COPYRIGHT © 2018 BY THORLABS				
VALUES IN PARENTHESIS ARE CALCULATED AND MAY CONTAIN ROUND OFF ERRORS				
ITEM #	APPROX WEIGHT	SM05PD5A .005 kg		