

F9J "	89G7 F-DHC B.	B5A 9#85H9.

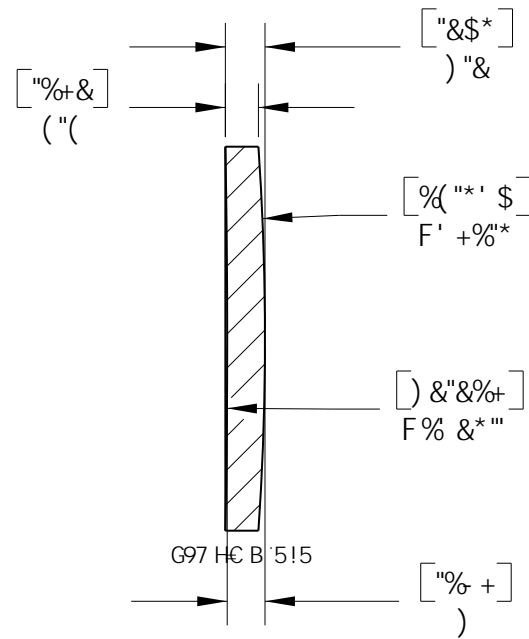
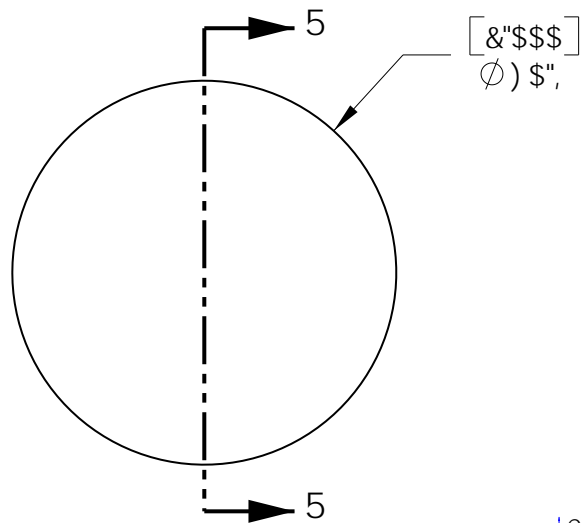

I B7C 5H98

G97 HC B'5!5

*C 75@@B; Hk. %\$\$\$a a
 657?: C 75@ --)"+a a
 B89L. %)%) 4 *'' ba
 89G= B'K 5J 9@B; Hk. '''' ba
 G7 F5H7 <#8 ≠ .(' \$&\$
 8-5A 9HF HC @F 5B7 9. Ž\$\"\$\$a a # \"\$\"\$a a
 7 @95F '5D9FH F9. O- \$i
 7 9BHF 5HC B. ' 5F7 'A B
 7 9BHF 'H-? ?B9GG'HC @F 5B7 9. '-\$\"%a a
 7 <5A: 9F '\$\"&\$a a '5H() \$5@G<5FD'98; 9G
 98; 9Hk-? ?B9GG'5GGI A-B; 'G<5FD'98; 9
 5B8; 9B'69.C F97 <5A: 9F

BCH9.
 :CF`B: CFA 5HCB`CB@M
 BCH: CF`A 5BI : 57H F-B;

5@I B+G; 9B`B`A @A 9HFG

HC@F5B79G	B5A 9	85H9
I B@GGC H: 9FK @9 GD97 ≠ 98.	8F5K B	5D)#& #&\$ \$*
8-A 9BGC BG5F9-B`B7<9G	9B: '5DDF"	HC)#& #&\$ \$*
@B95F HC@F5B79G	A:: '5DDF"	HC)#& #&\$ \$*
...Hk C D@57 9897-A 5@ ±\$\"\$%\$	DFC DF-9H6FM5B8 7CB: B9BH5@	
...Hk F99 D@57 9897-A 5@ ±\$\"\$%\$	Hk-9 B: CFA 5HCB 7C B H5 B98`B Hk-G	8F5K B: '6Hk-9GC @DFC D9F HMC:
5B: I @5F. '+' \$H	Hk C F @56Gz-B7 \"5B MF9DFC 8I 7 HCB	B D5FHC F 5G5 K <C @K Hk C I H
GI F: 57 9: B-G<.\" &A =FC-B7 <9G	Hk-9K F H9B`D9FA GGC B C:	Hk C F @56Gz-B7 \"GDFC <6+98"
D5F5 @@CA. \"\$\"\$&		
: @5B 9CG \"\$\"\$&		
GF 5 ≠ <H 9CG \"\$\"\$&		
7 C B7 9B HF =7 H M \"\$\"\$&		
D9F D9B 8-7 I @5F H M \"\$\"\$&		
Hk F95 8. 7 @5GG&: #I		

Hk C F @5 6Gz-B 7 \" DC '6CL\" **	
B9K HC B`B>	
H# @.	
«) \$\", a a '6?+ 'DC G+H 9'A -BI @7I G @9BG	
A 5H9F 5@	G@9 F9J \"
6?+ž: fUXY '5	5 5
G7 5 @. %%	G< 99H% C: %
8K ; \"BC \"	D5FH`BC \"
' (+\$!9\$%	@9% ' (