

F9J "	89G7 F-DHC B.	B5A 9#85H9.

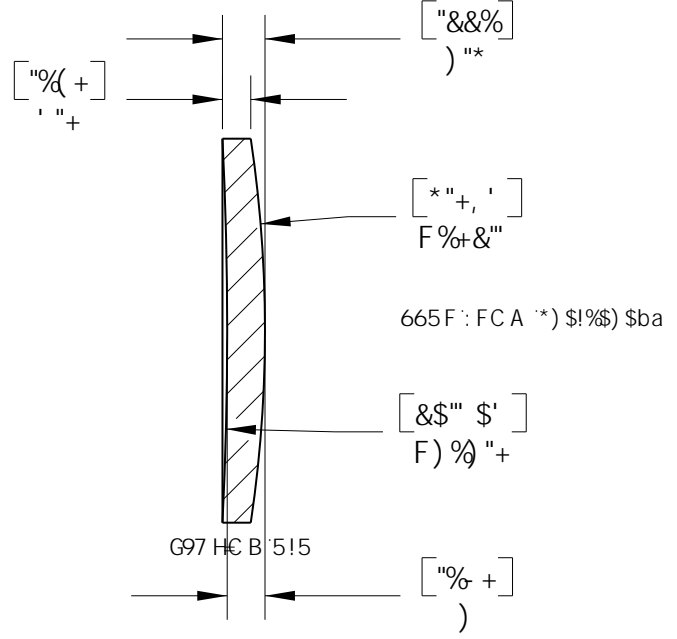
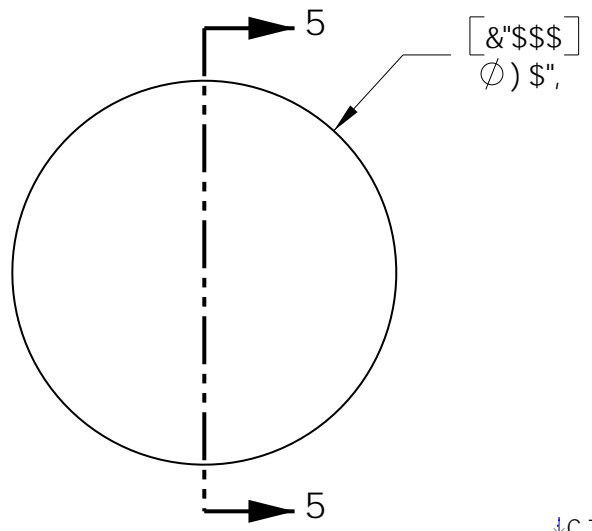

\*C 75@9B; Hk. )\$\$"Sa a  
657?: C 75@ (-)%"a a  
B 89L. %) %' 4 \*' ' ba  
89G= B 'K 5J 9@B; Hk. ' \*' ' ba  
G7 F5H7 <#8 = .(' \$&\$  
8-5A 9H9F HC @F5B79. Ž"\$Sa a # \$"%Sa a  
7 @95F '5D9FH F9. O- \$i  
7 9BHF5HC B. ' '5F7 'A B  
7 9BH9F 'Hk-? B9GGHC @F5B79. '-%"a a  
7 <5A : 9F '\$"&Sa a '5H() \$'5@G<5FD'98; 9G  
98; 9Hk-? B9GG5GGI A B; 'G<5FD'98; 9  
5B8; √ 9B '69. C F97 <5A : 9F

BCH9.  
: CF 'B: CFA 5HC B 'CB@M  
BCH: CF'A 5BI : 57H F-B;

5@I B+G; √ 9B 'B'A @A 9HFG

HC@F5B79G	B5A 9	85H9
1 B@9GGCH: 9FK @9 GD97 =98.	8F5K B	5D )#&)#&\$S*
8-A 9BGCBG5F9-B 'B7<9G	9B: '5DDF"	HC )#&)#&\$S*
@B95F HC@F5B79G:	A:: '5DDF"	HC )#&)#&\$S*
"Hk C D@579897-A 5@ ±\$S%\$	DFC DF-96FM5B87CB: -98H5@	
"Hk F99D@579897-A 5@ ±\$S%\$)	Hk-9 B: CFA 5HC B 7 C B H5 B 98 B Hk-G	
5B: 1 @5F. '±' \$F"	8F5K B: 'Gk-9 GC @DFC D9F HMC:	
GI F: 579: B-G<." &A =FC-B7<9G	Hk C F @56Gz-B7 "5BMF9DFC 8I 7 HC B	
D5F5 @9@CA. '\$S\$&	B D5FHC F 5G5 K <C @K Hk C I H	
: @5B9CG '\$S\$&	Hk-9 K F H9B 'D9FA GGC B C:	
GF5 = <H9CG '\$S\$&	Hk C F @56Gz-B7 "GDFC <6+98"	
7 C B7 9BHF =7 H M '\$S\$&		
D9FD9B 8-7 1 @5F H M '\$S\$&		
Hk F958. 7 @5GG&: #1		

Hk C F @56Gz-B7 " DC '6CL" '* B9K HC B 'B>	
H#I@.	
« )\$", a a '6?+ 'DC G+H 9'A -BI -G7I G @9BG	
A 5H9F 5@ 6?+ž: fUXY '5	G@9 F9J " 5 5
G7 5@9. %%	G<99H% C: %
8K ; ""BC " (, (, !9\$%	D5FH'BC " @9%)! '6