

M3 x 0.5 INTERNAL THREAD
6.4mm [0.25in] MAX THREAD DEPTH

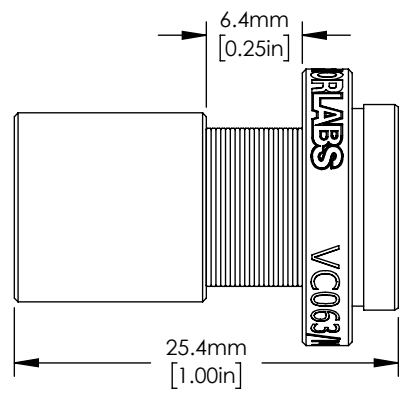

MAXIMUM RECOMMENDED EXTENSION

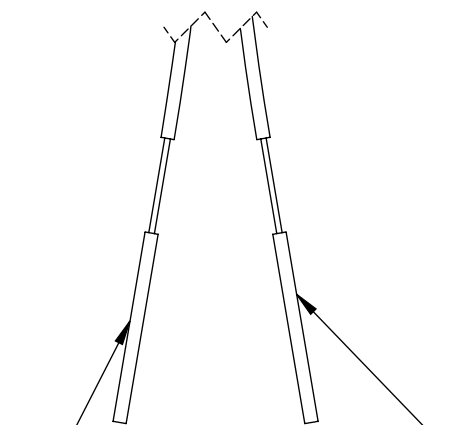
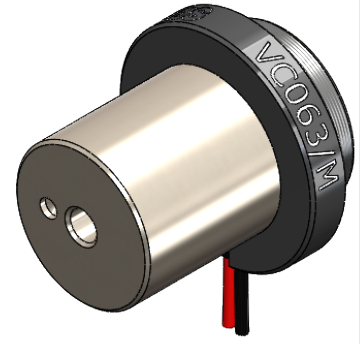

NEGATIVE WIRE BLACK
381.0mm [15.00in] LONG

POSITIVE WIRE RED
381.0mm [15.00in] LONG

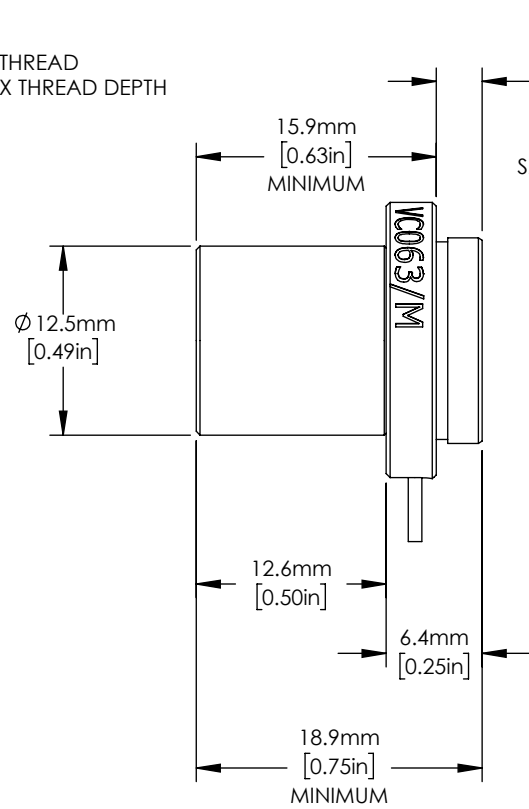

M3 x 0.5 INTERNAL THREAD
3.18mm [0.13in] DEEP

SM05 (∅ 0.535-40) SERIES
EXTERNAL THREAD

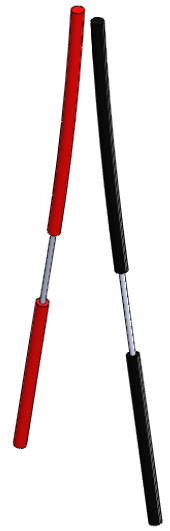
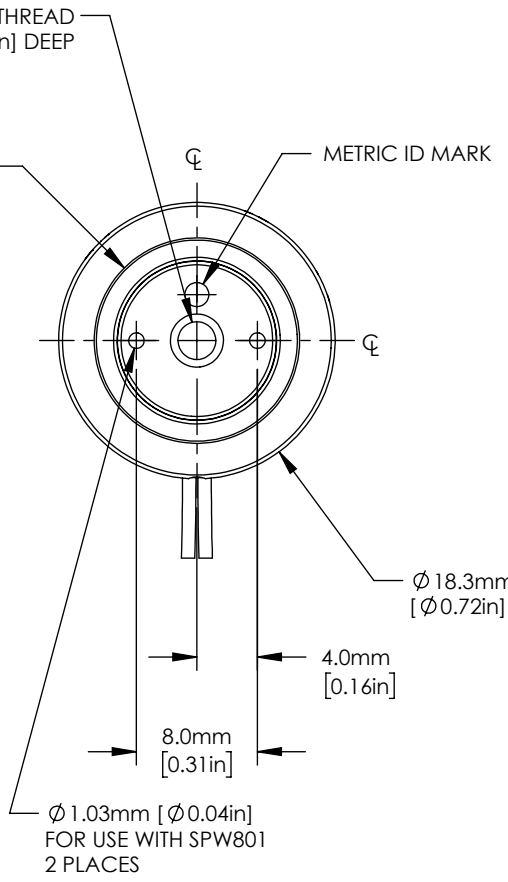

NOTES/SPECIFICATIONS:

1. FORCE CONSTANT: 0.74N/A*
2. TRAVEL: 6.3mm
3. COIL MASS: 7g
4. MAGNET MASS: 7g
5. COIL RESISTANCE: 1.9Ω
6. COIL INDUCTANCE: 167μH
7. MAXIMUM 100% DUTY CYCLE CURRENT @ 60°C: 0.85A
8. MAXIMUM 100% DUTY CYCLE CURRENT @ 200°C: 1.76A

*SPECIFIED AT THE STROKE POSITION THAT PROVIDES THE MAXIMUM CONTINUOUS FORCE WHEN DRIVEN WITH 1 A CURRENT

FOR INFORMATION ONLY
NOT FOR MANUFACTURING PURPOSES

DRAWING PROJECTION		
NAME	DATE	
DRAWN JC	07/NOV/19	
APPROVAL CT	08/NOV/19	
COPYRIGHT © 2020 BY THORLABS		
VALUES IN PARENTHESIS ARE CALCULATED AND MAY CONTAIN ROUND OFF ERRORS		

THORLABS www.thorlabs.com	
6.3mm VOICE COIL ACTUATOR	
MATERIAL	N/A
ITEM #	VC063/M
APPROX WEIGHT	0.02 kg
REV	A