



SM05PD7A

### Description

Thorlabs' SM05PD7A photodiode is ideal for measuring both pulsed and CW fiber light sources by converting optical power into electrical current. The detector is mounted in a convenient SM05 (Ø0.535"-40) externally-threaded tube for easy mounting and integration into existing setups. The photodiode is a *Type A (Cathode Grounded)* arrangement, and the pin codes for the specific package can be found in the drawing below. The photodiode anode produces a current, which is a function of both the incident light power,  $P$ , and the wavelength,  $\lambda$ . The responsivity,  $\mathfrak{R}(\lambda)$ , can be read from the plot on the following page to estimate the amount of photocurrent. This current can be converted to a voltage by placing a load resistor ( $R_L$ ) from the photodiode anode to the circuit ground. Where  $P$  is the power, the output voltage is expressed by

$$V_o = P \times \mathfrak{R}(\lambda) \times R_L$$

The bandwidth,  $f_{BW}$ , and the rise time response,  $t_R$ , are determined from the diode capacitance,  $C_j$ , and the load resistance,  $R_L$ , as shown below. The diode capacitance can be lowered by placing a bias voltage from the photodiode cathode to the circuit ground.  $\Omega$

$$f_{BW} = \frac{1}{(2\pi)R_L C_j}, t_R = \frac{0.35}{f_{BW}}$$

### Specifications

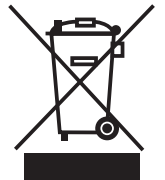

Specifications <sup>a</sup>		
Wavelength Range	$\lambda$	150 - 550 nm
Peak Wavelength	$\lambda_p$	440 nm
Responsivity	$\mathfrak{R}(\lambda)$	0.12 A/W
Active Area	-	2.2 mm x 2.2 mm
Rise/Fall Time ( $R_L=50 \Omega$ , 5 V, 405 nm)	$t_r/t_f$	55 ns / 55 ns (Typ.)
NEP, Typical (440 nm, 5 V)	W/√Hz	$1.3 \times 10^{-14}$
Dark Current (5 V)	$I_d$	15 pA (Typ.) 40 pA (Max)
Capacitance (0 V)	$C_j$	1000 pF (Typ.)
Package	-	SM05, External Thread
Sensor Material	-	GaP
Corresponding Unmounted Diode	-	FGAP71

a. Unless otherwise noted, all measurements are performed at 25 °C ambient temperature.

Maximum Rating	
Max Bias (Reverse) Voltage	5 V
Reverse Current	2 mA
Operating Temperature	-40 to 125 °C
Storage Temperature	-40 to 125 °C

## Recommended Circuit Diagram

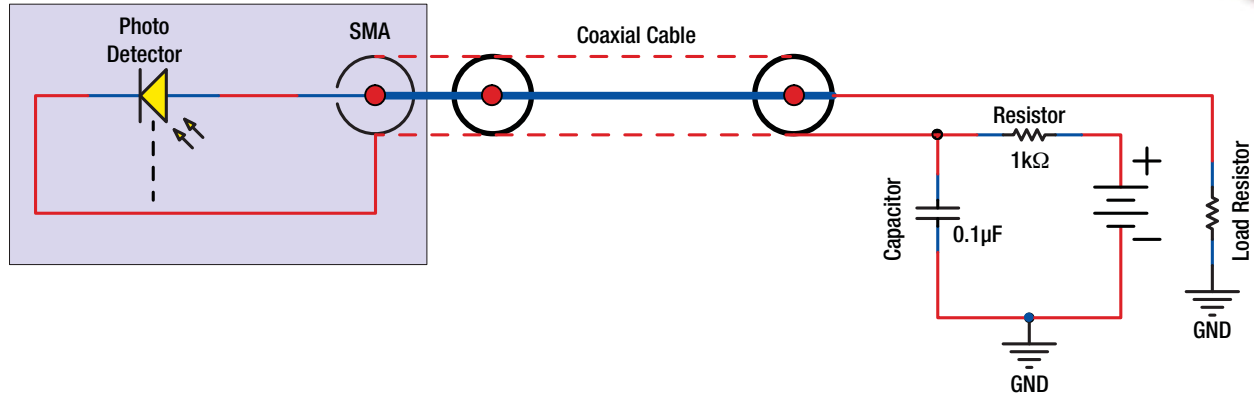

## Responsivity Graph

The responsivity of a photodiode is a measure of its sensitivity to light and is defined as the ratio of the photocurrent  $I_p$  to the incident light power  $P$  at a given wavelength:

$$R_\lambda = \frac{I_p}{P}$$

In other words, it is a measure of the effectiveness of the conversion of light power into electrical current. Responsivity varies from lot to lot and with the wavelength of the incident light, applied reverse bias, and temperature. It increases slightly with applied reverse bias due to improved charge collection efficiency in the photodiode. An increase or decrease in the temperature changes the width of the band gap, which will vary inversely with the temperature change.

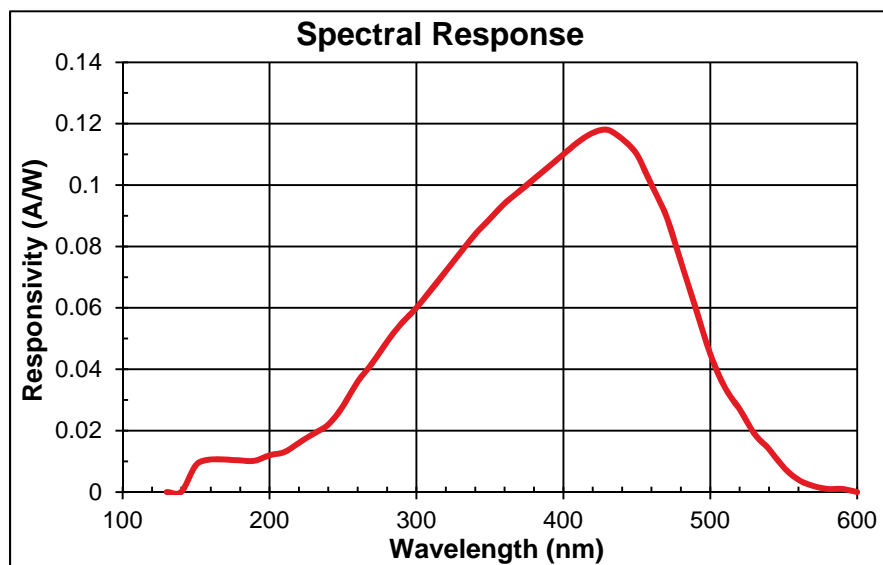

## Drawing

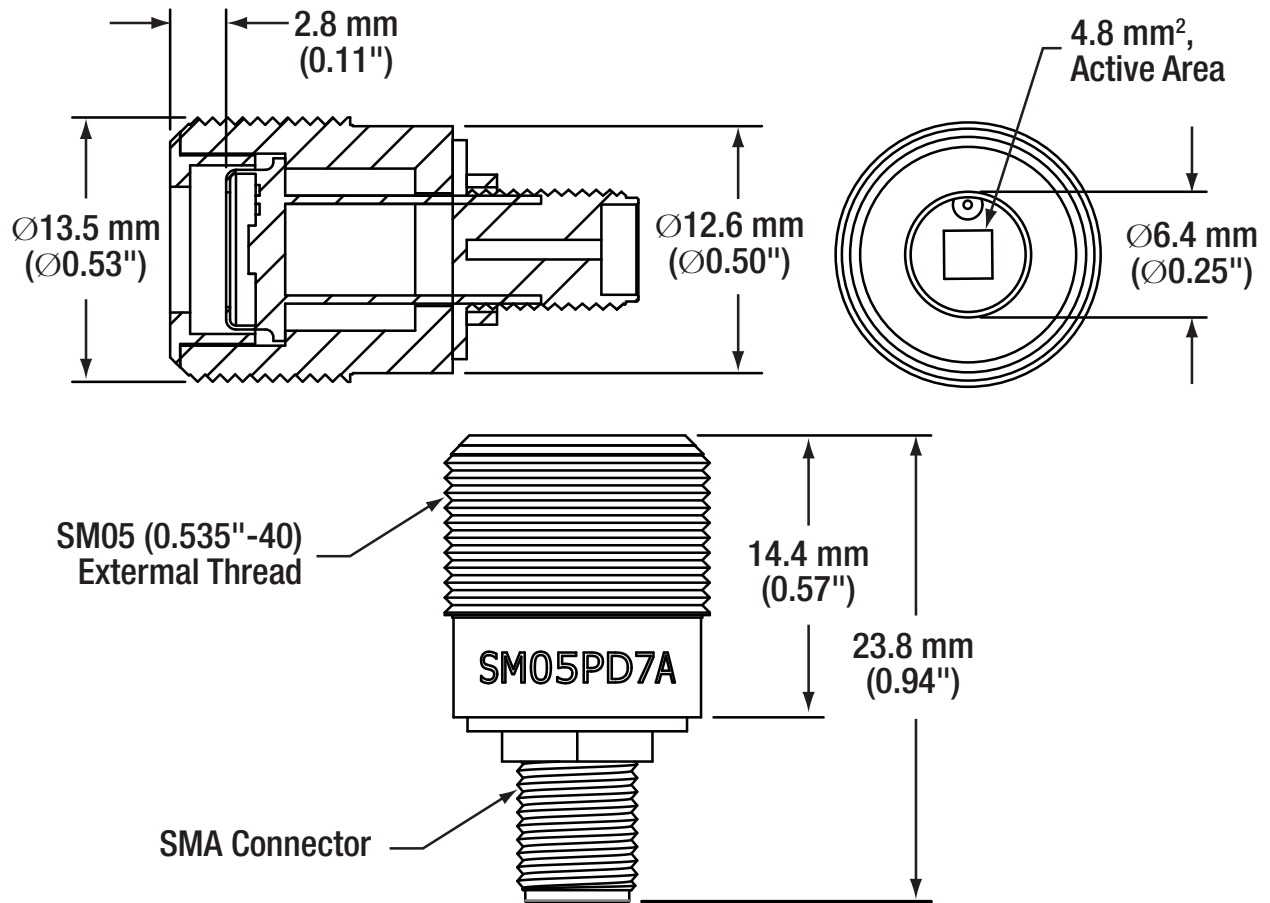

## *Precautions and Warranty Information*

---

These products are ESD (electro static discharge) sensitive and as a result are not covered under warranty. In order to ensure the proper functioning of a photodiode care must be given to maintain the highest standards of compliance to the maximum electrical specifications when handling such devices. The photodiodes are particularly sensitive to any value that exceeds the absolute maximum ratings of the product. Any applied voltage in excess of the maximum specification will cause damage and possible complete failure to the product. The user must use handling procedures that prevent any electro static discharges or other voltage surges when handling or using these devices.

Thorlabs, Inc. Life Support and Military Use Application Policy is stated below:

THORLABS' PRODUCTS ARE NOT AUTHORIZED FOR USE AS CRITICAL COMPONENTS IN LIFE SUPPORT DEVICES OR SYSTEMS OR IN ANY MILITARY APPLICATION WITHOUT THE EXPRESS WRITTEN APPROVAL OF THE PRESIDENT OF THORLABS, INC. As used herein:

- 1. Life support devices or systems are devices or systems which, (a) are intended for surgical implant into the body, or (b) support or sustain life, and whose failure to perform, when properly used in accordance with instructions for use provided in the labeling, can be reasonably expected to result in a significant injury to the user.*
- 2. A critical component is any component in a life support device or system whose failure to perform can be reasonably expected to cause the failure of the life support device or system or to affect its safety or effectiveness.*
- 3. The Thorlabs products described in this document are not intended nor warranted for usage in Military Applications.*