

DIMENSIONS WHEN INSTALLED ON THE LFE1220W FRAMES

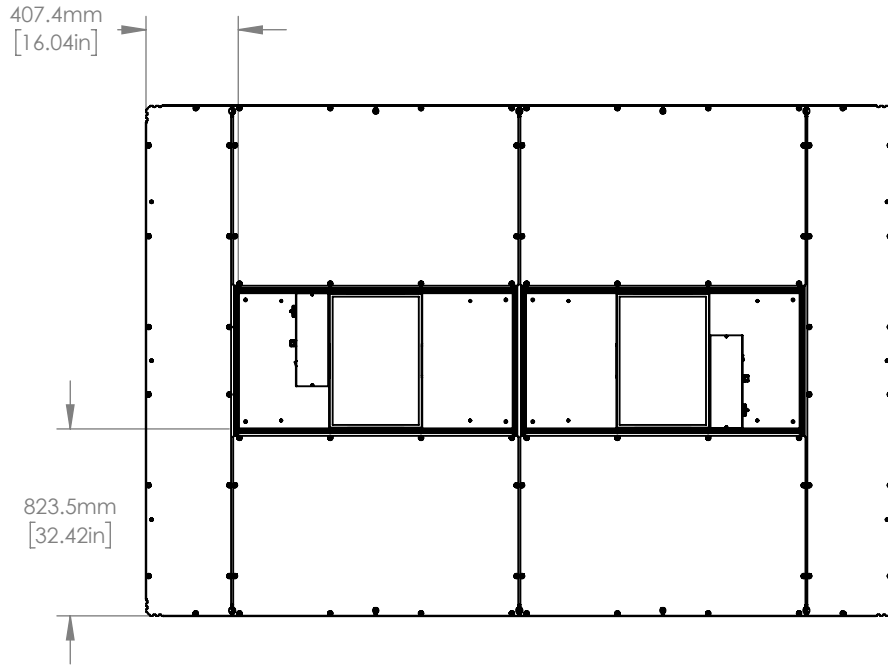

DIMENSIONS OF FAN UNIT

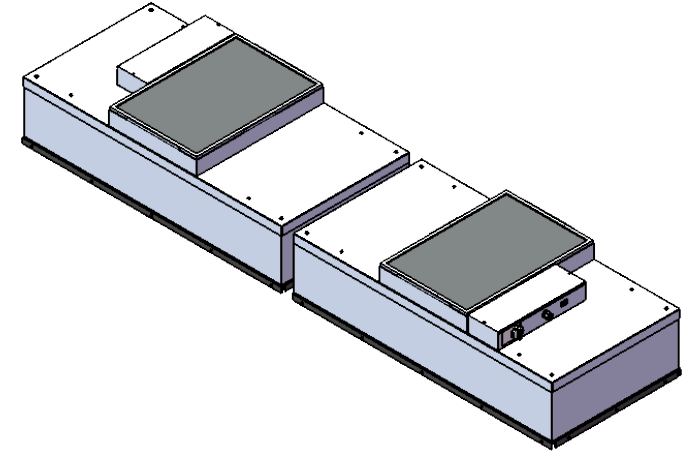

REFER TO HANDBOOK FOR THE LIST OF FASTENERS AND MOUNTING ACCESSORIES

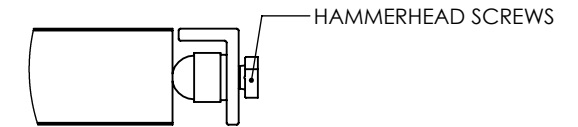
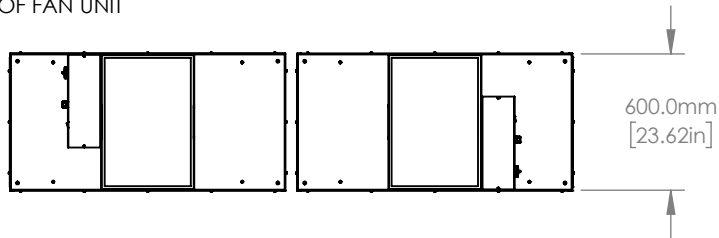

DETAIL A
SCALE 1 : 2

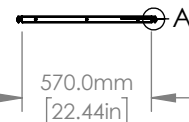
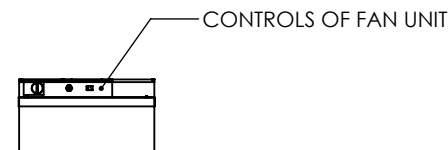
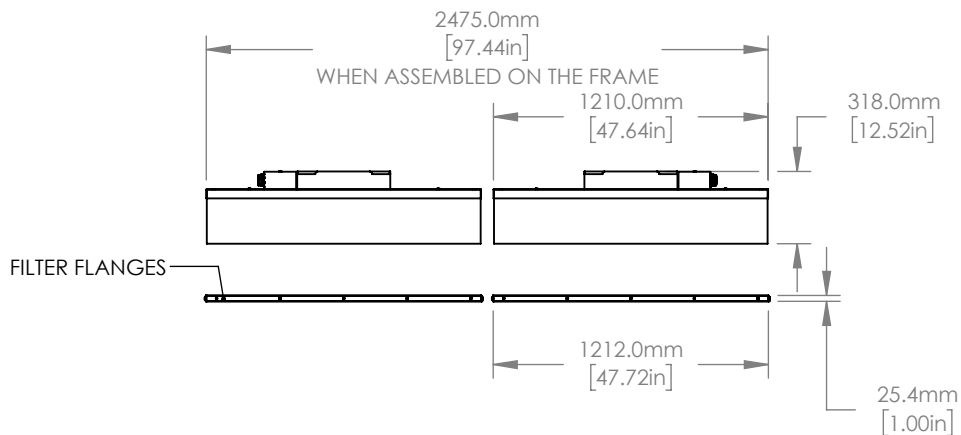

FOR INFORMATION ONLY
NOT FOR MANUFACTURING PURPOSES

DRAWING PROJECTION

	NAME	DATE
DRAWN	IK	07/JAN/22
APPROVAL	DJG	07/JAN/22

COPYRIGHT © 2022 BY THORLABS

VALUES IN PARENTHESIS ARE CALCULATED AND MAY CONTAIN ROUND OFF ERRORS

THORLABS
www.thorlabs.com

HEPA FILTER FAN & HARDWARE ASSEMBLY KIT
FOR LFE1220W, 115V FAN UNITS

MATERIAL	N/A	REV A
----------	-----	----------

ITEM #	LFEF2-US	APPROX WEIGHT	67 kg
--------	----------	---------------	-------