

F9J "	89G7 F-DHC B.	B5A 9#85H9.

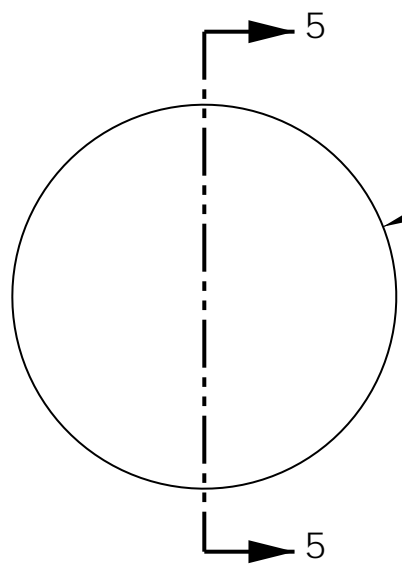

["%\$\$\$"]
∅ &)"(

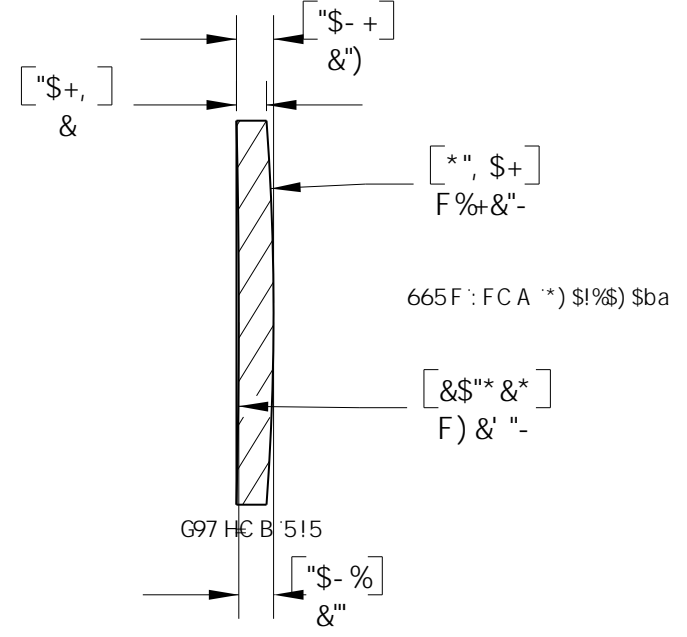

:C 75@@B; Hk.)\$\$"\$a a
657?: C 75@ (-+"+a a
B89L. %)%) '4 *'' ba
89G≠ B'K 5J 9@B; Hk. *'' ba
G7 F5H7 <#8≠ .('(\$#&\$
8-5A 9H9F HC @F5B79. Ž"\$\$\$a a #"\$%\$a a
7 @95F 5D9FH F9. O-\$i
7 9BH5HC B. " 5F7 'A B
7 9BH9F Hk-? B9GGHC @F5B79. -\$%a a
7 <5A : 9F '\$&\$a a 5H() \$5@G<5FD'98; 9G
98: 9Hk-? B9GG5GGI A B; G<5FD'98; 9
5B8; ∫ 9B 69. C F97 <5A : 9F

BCH9.
:CF B: CFA 5HCB CB@M
BCH: CFA 5BI : 57H F-B;

5@! B+G; ∫ 9B B'A @A 9HFG
5B8 B7 <9G

HC@F5B79G	B5A 9	85H9
1 B@9GC H: 9FK @9 GD97 ≠ 98.	8F5K B	5D)#& #&\$ \$*
8-A 9BGC BG5F9-B B7 <9G	9B: 5DDF" HC)#& #&\$ \$*	
@B95F HC @F5B79G	A: 5DDF" HC)#& #&\$ \$*	
...HK C D@57 9897-A 5@ ±\$"\$%	DFC DF-96FM5B87CB: B9BH5@	
...H: F99 D@57 9897-A 5@ ±\$"\$%	H: 9B: CFA 5HCB 7CBH5B98 B Hk G	
5B: 1 @5F. ±' \$H"	8F5K B: 6H: 9GC @DFC D9F HMC:	
GI F: 579: B-G<." &A ∫ FC B7 <9G	H: C F @56Gz-B7 " 5B MF9DFC 8I 7 HC B	
D5F5 @9@CA. "\$\$\$&	B D5FHC F 5G5 K <C @K Hk C I H	
: @5B 9CG "\$\$\$&	H: 9K F H9B D9FA @GC B C:	
GF 5≠ <H 9CG "\$\$\$&	H: C F @56Gz-B7 " 6DFC <6+98"	
7C B7 9BH ∫ H M "\$\$\$&		
D9F D9B 8-71 @5F H M "\$\$\$&		
H: F958. 7 @5GG&: #H		

Hk C F @56G B7 " DC 6CL" ** B9K HC B B>	
H# @.	
« &)"(a a '6?+ DC G+H 9A 9B @7I G @9B G	
A 5H9F 5@ 6?+ž: fUXY 5	G#9 F9J " 5 5
G7 5@. %%	G<99H% C: %
8K ; "BC" (, ' -!9\$%	D5FH BC " @9%&*% 6