

InGaAs Photodiode 800-1700 nm

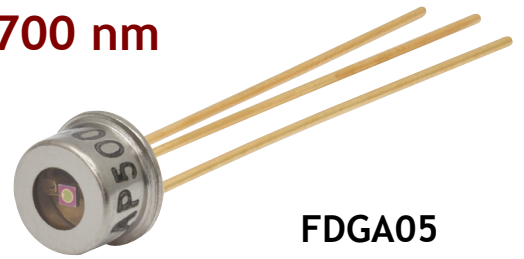

FDGA05

Description

The Thorlabs FDGA05, InGaAs photodiode is ideal for measuring both pulsed and CW fiber light with sensitivity from 800 to 1700 nm. The detector is housed in a TO-46 package for ease of use and integration into an existing system. Under reverse bias application, the photodiode anode produces a current, which is a function of the incident light power and the wavelength. The responsivity $\mathfrak{R}(\lambda)$, can be read from Figure 1 to estimate the amount of photocurrent per incident light energy. The photodiode current can be converted to a voltage by placing a load resistor (R_L) between the photodiode anode and the circuit ground. The output voltage is derived as:

$$V_o = P \times \mathfrak{R} \times R_L$$

The bandwidth, f_{BW} , and the rise time response, t_R , are determined from the diode capacitance, C_j , and the load resistance, R_L , as shown below. The diode capacitance can be lowered by placing a bias voltage from the photodiode cathode to the circuit ground.

$$f_{BW} = \frac{1}{(2\pi)R_L C_j}, t_R = \frac{0.35}{f_{BW}}$$

Specifications¹

Specification		Value
Wavelength Range	λ	800 - 1700 nm
Peak Wavelength	λ_p	1550 nm
Responsivity	$\mathfrak{R}(\lambda_p)$	0.95 A/W
Active Area		0.196 mm ²
Rise/Fall Time ($R_L=50 \Omega$, 5 V)	t_r/t_f	2.5 ns
NEP, Typical (1550 nm)	W//Hz	2.0×10^{-14}
Dark Current (5 V)	I_d	6 nA (typ) 30 nA (max)
Capacitance (5 V)	C_j	10 pF
Package		TO-46
Sensor Material		InGaAs
Maximum Rating		
Max Bias (Reverse) Voltage		20 V
Operating Temperature		-40 to 85 °C
Storage Temperature		-55 to 125 °C

¹Unless otherwise noted, all measurements are performed at 25 °C ambient temperature.

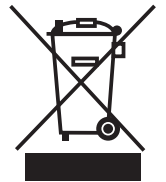

Typical Spectral Intensity Distribution

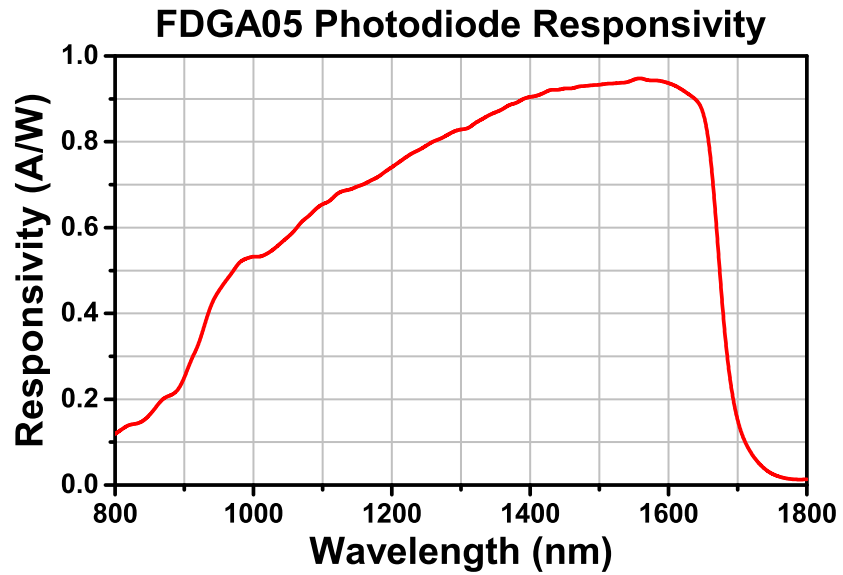

Recommended Circuit

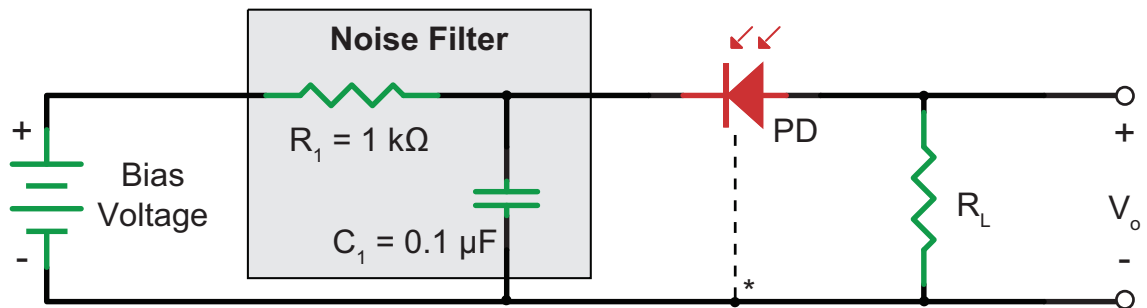

* Case ground for PD with a third lead.

Drawing

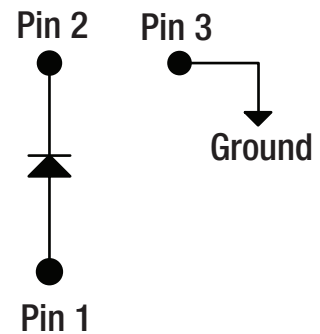
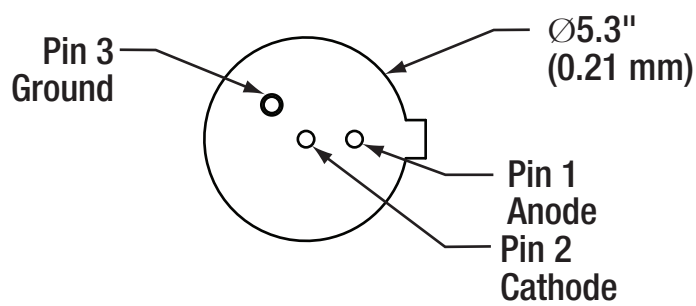
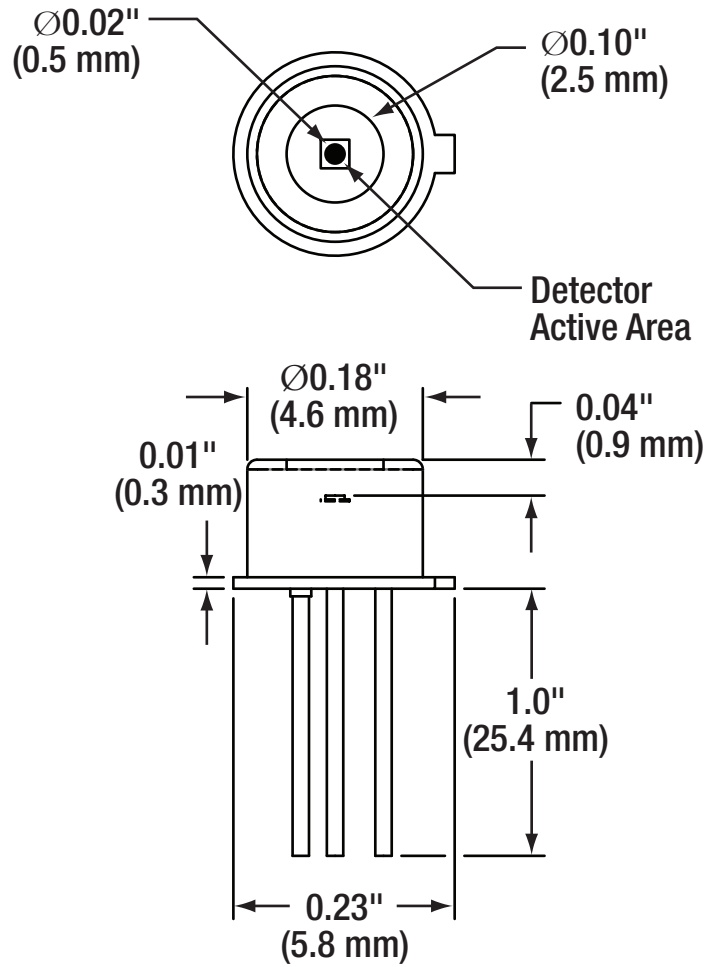

Precautions and Warranty Information

These products are ESD (electro static discharge) sensitive and as a result are not covered under warranty. In order to ensure the proper functioning of a photodiode care must be given to maintain the highest standards of compliance to the maximum electrical specifications when handling such devices. The photodiodes are particularly sensitive to any value that exceeds the absolute maximum ratings of the product. Any applied voltage in excess of the maximum specification will cause damage and possible complete failure to the product. The user must use handling procedures that prevent any electro static discharges or other voltage surges when handling or using these devices.

Thorlabs, Inc. Life Support and Military Use Application Policy is stated below:

THORLABS' PRODUCTS ARE NOT AUTHORIZED FOR USE AS CRITICAL COMPONENTS IN LIFE SUPPORT DEVICES OR SYSTEMS OR IN ANY MILITARY APPLICATION WITHOUT THE EXPRESS WRITTEN APPROVAL OF THE PRESIDENT OF THORLABS, INC. As used herein:

- 1. Life support devices or systems are devices or systems which, (a) are intended for surgical implant into the body, or (b) support or sustain life, and whose failure to perform, when properly used in accordance with instructions for use provided in the labeling, can be reasonably expected to result in a significant injury to the user.*
- 2. A critical component is any component in a life support device or system whose failure to perform can be reasonably expected to cause the failure of the life support device or system or to affect its safety or effectiveness.*
- 3. The Thorlabs products described in this document are not intended nor warranted for usage in Military Applications.*