

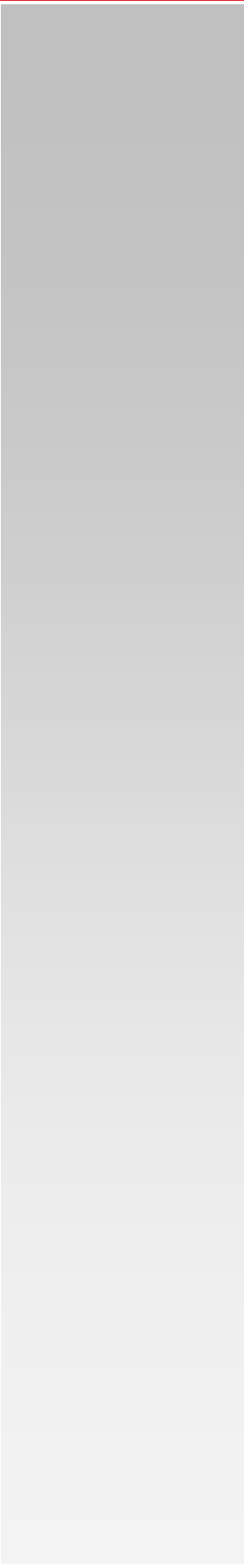

PMTSS Series Photomultiplier Tube

User Guide



Copyright August 9, 2016 Thorlabs, Inc. All rights reserved.

Information in this document is subject to change without notice. No part of this publication may be reproduced, stored in a retrieval system, or transmitted in any form or any means electronic or mechanical, including photocopying and recording for any purpose other than the purchaser's personal use without the written permission of Thorlabs, Inc.

Thorlabs, Inc.
108 Powers Court
Sterling, VA 20166
703-651-1700



















Table of Contents

Chapter 1	Warning Symbol Definitions.....	1
Chapter 2	Safety.....	2
Chapter 3	Description	3
	3.1. <i>Front Panel Overview</i>	3
	3.2. <i>Back Panel Overview</i>	4
Chapter 4	Getting Started	5
	4.1. <i>Ordering Codes</i>	5
	4.2. <i>Unpacking and Inspection</i>	5
	4.3. <i>Setting up PMTSS Series</i>	6
	4.3.1. Preparation.....	6
	4.3.2. Expanding the Detection Channels (PMTSS2).....	6
Chapter 5	Maintaining the PMTSS Series.....	10
	5.1. <i>Storing the PMTSS Series</i>	10
Chapter 6	Connection and Programming.....	11
Chapter 7	Performance Plots	12
Chapter 8	Specifications.....	13
	8.1. <i>General Specifications</i>	13
	8.2. <i>Performance Specifications</i>	13
Chapter 9	Mechanical Drawing	14
Chapter 10	Cable Wiring Diagram	17
Chapter 11	Certifications and Compliance.....	18
Chapter 12	Warranty.....	19
Chapter 13	Regulatory	20
	13.1. <i>Waste Treatment is Your Own Responsibility</i>	20
	13.2. <i>Ecological Background</i>	20
Chapter 14	Thorlabs Worldwide Contacts.....	21

Chapter 1 Warning Symbol Definitions

Below is a list of warning symbols you may encounter in this manual or on your device.

Symbol	Description
	Direct Current
	Alternating Current
	Both Direct and Alternating Current
	Earth Ground Terminal
	Protective Conductor Terminal
	Frame or Chassis Terminal
	Equipotentiality
	On (Supply)
	Off (Supply)
	In Position of a Bi-Stable Push Control
	Out Position of a Bi-Stable Push Control
	Caution: Risk of Electric Shock
	Caution: Hot Surface
	Caution: Risk of Danger
	Warning: Laser Radiation
	Caution: Spinning Blades May Cause Harm

Chapter 2 Safety

All statements regarding safety of operation and technical data in this user guide will only apply when the unit is operated correctly. Please read the following warnings and cautions carefully before operating the device.



CAUTION



DO NOT use the device for anything other than its intended use.

Chapter 3 Description

Thorlabs' PMT (Photomultiplier Tube) modules are designed for easy integration of PMT detection into imaging systems and are ideal for laser scanning microscopy. These side-on PMTs have a broadband spectral response (185 – 900 nm), gain $> 10^7$, and a fast response time (1.4 ns). The modules use a Cockcroft-Walton circuit with low power consumption. A BNC connector supplies the output data from the detectors. The PMTSS series consist of PMTSS (Stand-Alone PMT), PMTSS2 (Two-Channel PMT), and PMTSS2-SCM (Single-Channel Add-on PMT).

The PMTSS2 module consists of two multi-alkali standard sensitivity PMTs, a DFM dichroic filter cube insert, and a base. The filter insert enables easy exchange of dichroic mirror/emission filter sets. This configuration enables dual-channel detection of signals at two different wavelengths. The input port of the filter block features SM1 (1.035"-40) threading, which is directly compatible with a wide array of Thorlabs' SM1 Lens tubes and fiber collimation adapters. The module has an SMA fiber connector for attaching an SMA-terminated multimode fiber patch cable. The base of the module is equipped with 1/4" (M6) slots for attachment to an imperial or metric optical table or breadboard. Due to the weight of the unit, we recommend placing it on a table or breadboard. Add on the PMTSS2-SCM module to the PMTSS2 module to increase the number of detection channels. The two-channel PMTSS2 modules are expandable to up to eight detection channels.

The PMTSS is a stand-alone photosensor module in a compact aluminum housing. It is a multi-alkali PMT detector without any filter block and base. It has a C-mount internal thread. For compatibility with Thorlabs' SM1 lens tubes, convert the C-mount thread to external SM1 threads using Thorlabs' SM1A9 C-mount to SM1 adapter. For compatibility with a 30 mm cage system, attach an SM1T2 externally SM1-threaded coupler to the SM1A9, which is compatible with any of our SM1-threaded 30 mm cage plates.

3.1. Front Panel Overview

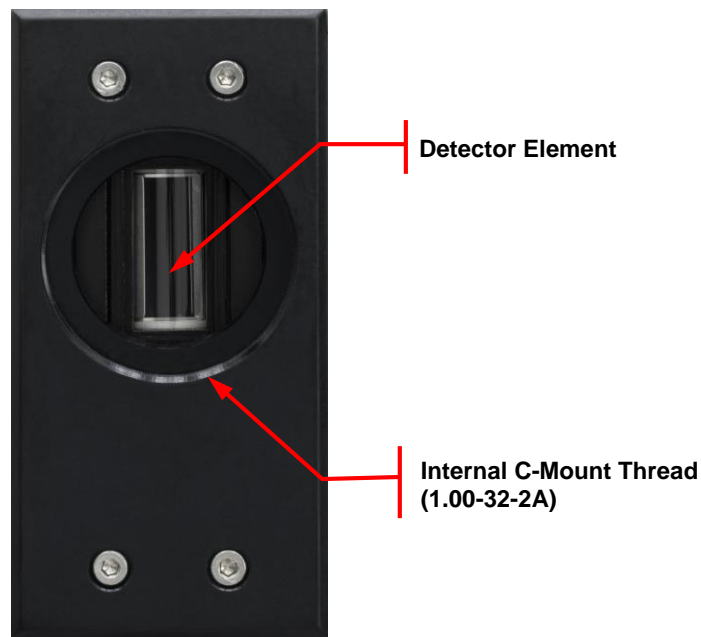

3.2. Back Panel Overview

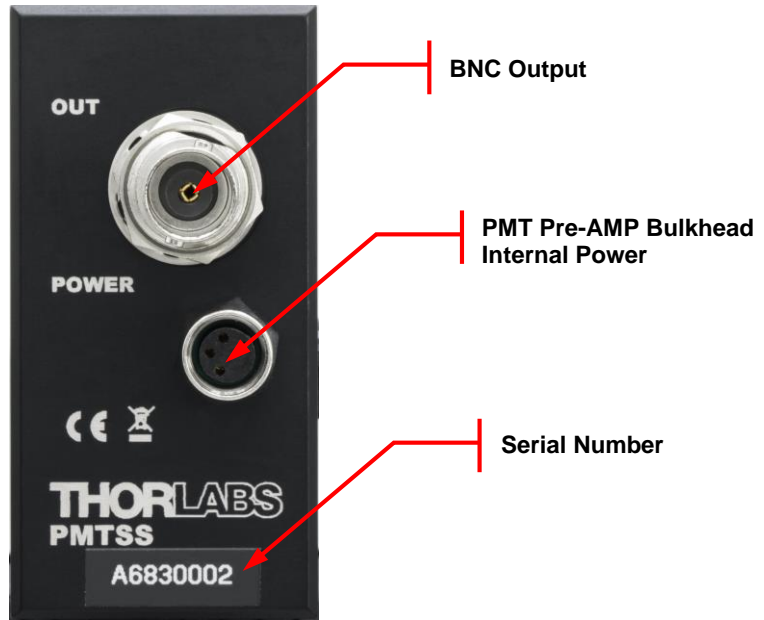

Chapter 4 Getting Started



This section is provided for those interested in getting the PMT up and running quickly.

4.1. Ordering Codes

Ordering Codes	Description
PMTSS	Stand-Alone Photomultiplier Tube
PMTSS2	Dual-Channel Photomultiplier Tube
PMTSS2-SCM	Single-Channel Add-On Photomultiplier Tube

4.2. Unpacking and Inspection

Open the package, and carefully remove the PMT and its accessories. The table lists the standard accessories shipped with the device.

Name	Quantity		
	PMTSS	PMTSS2	PMTSS2-SCM
			
PMT	1	2	1
Male M8 x 1 Connectors with Colored Wire Leads	1	2	1
M8 x 1 Extension Cords	1	2	1
Fiber Patch Cable	-	1	-
PMT Module Mount	-	-	1
PMT 2 Channel Assembly	-	1	-
C-Mount Cap	1	-	-

Inspect the device and its accessories for any missing parts or damage. If there is any problem, please contact Thorlabs by Phone: **973-300-3000** or email: **techsupport@thorlabs.com**.

4.3. Setting up PMTSS Series



WARNING



DO NOT switch on the light source until the setup is complete. Use proper eye and skin protection for the corresponding wavelength in use while setting up the photomultiplier tube to detect hazardous wavelengths, such as UV, blue lights, and other high intensity radiations.



WARNING



Use proper eye and skin protection for the corresponding wavelength in use while operating the photomultiplier tube with hazardous wavelengths, such as UV, blue lights, and other high intensity radiations.



CAUTION



DO NOT expose the photomultiplier tube to strong light sources (especially UV). They can temporarily increase the noise in the signal.

4.3.1. Preparation

1. Mount the PMT on your optical table or application.
2. Connect the PMT Pre-Amp Bulkhead Internal Power cable Pin 1 to a standard power supply and Pin 2 (0.25 – 1.2 V) to a voltage control unit.
3. Connect the output signal to a data acquisition system.
4. Align the light source to the PMT input, and switch on the light source.
5. Remove the C-Mount cap (PMTSS module).
6. Vary the voltage in the voltage control unit to control the PMT gain.

4.3.2. Expanding the Detection Channels (PMTSS2)

Add the PMTSS2-SCM module to the PMTSS2 module to increase the number of detection channels. The PMTSS2 module is expandable to up to eight detection channels.



CAUTION



DO NOT switch on the photomultiplier tube module while installing additional detection channels. Stray lights may temporarily increase the noise in the signal and may damage the detector element.

1. Use a 2 mm hex key to remove the setscrews (2x) from the PMT Face Plate, and remove the Fiber Couple Lens Tube.

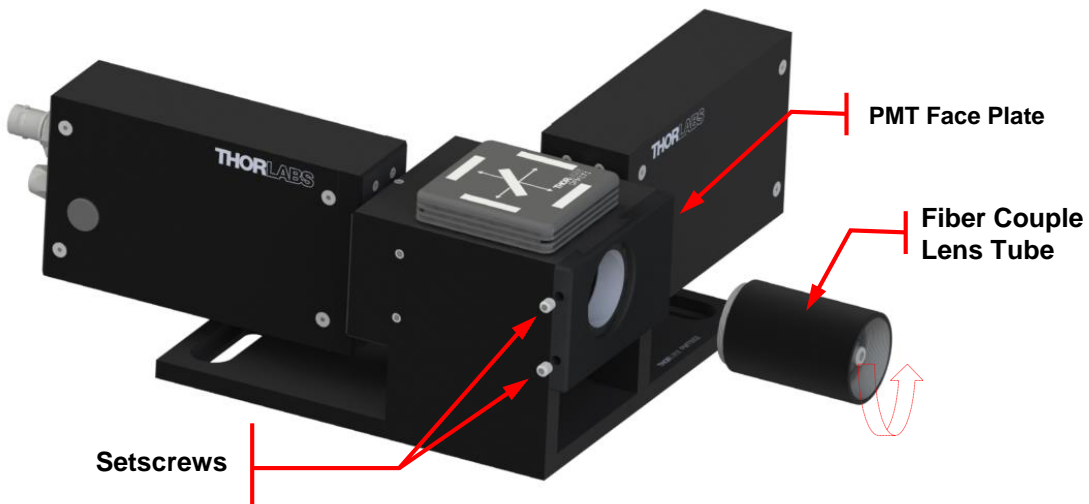

2. Slide the PMT Face Plate out of the assembly.

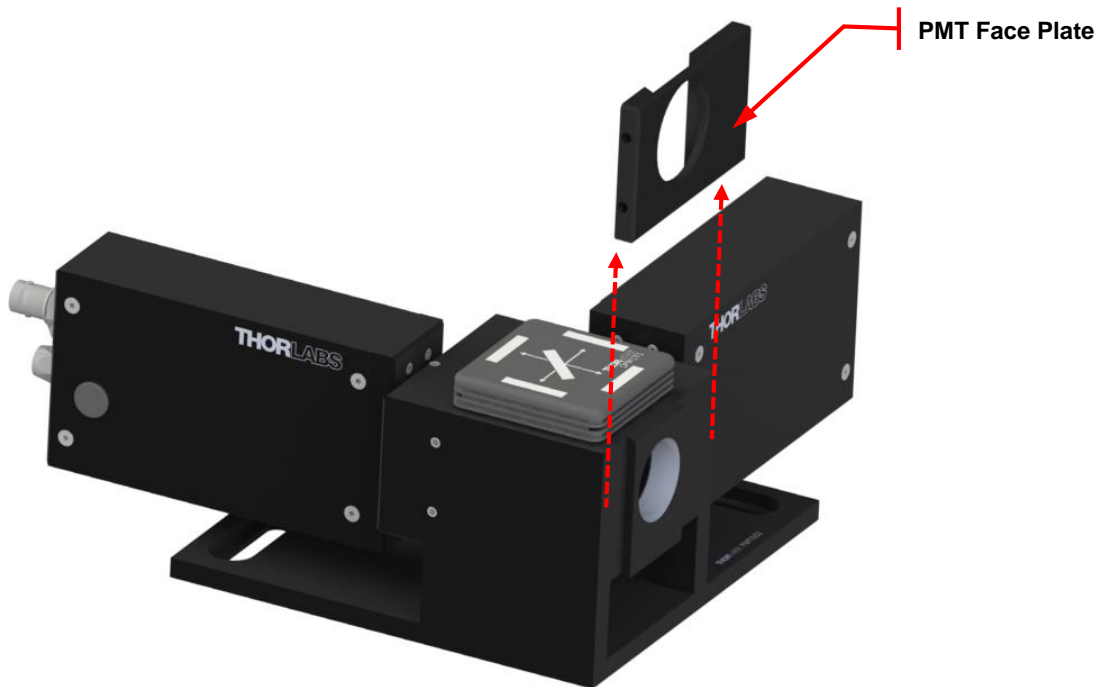

3. Use the 2 mm hex key to remove the setscrews (2x) from the PMTSS2-SCM module, and slide the PMTSS2 detection block onto the PMTSS2-SCM.

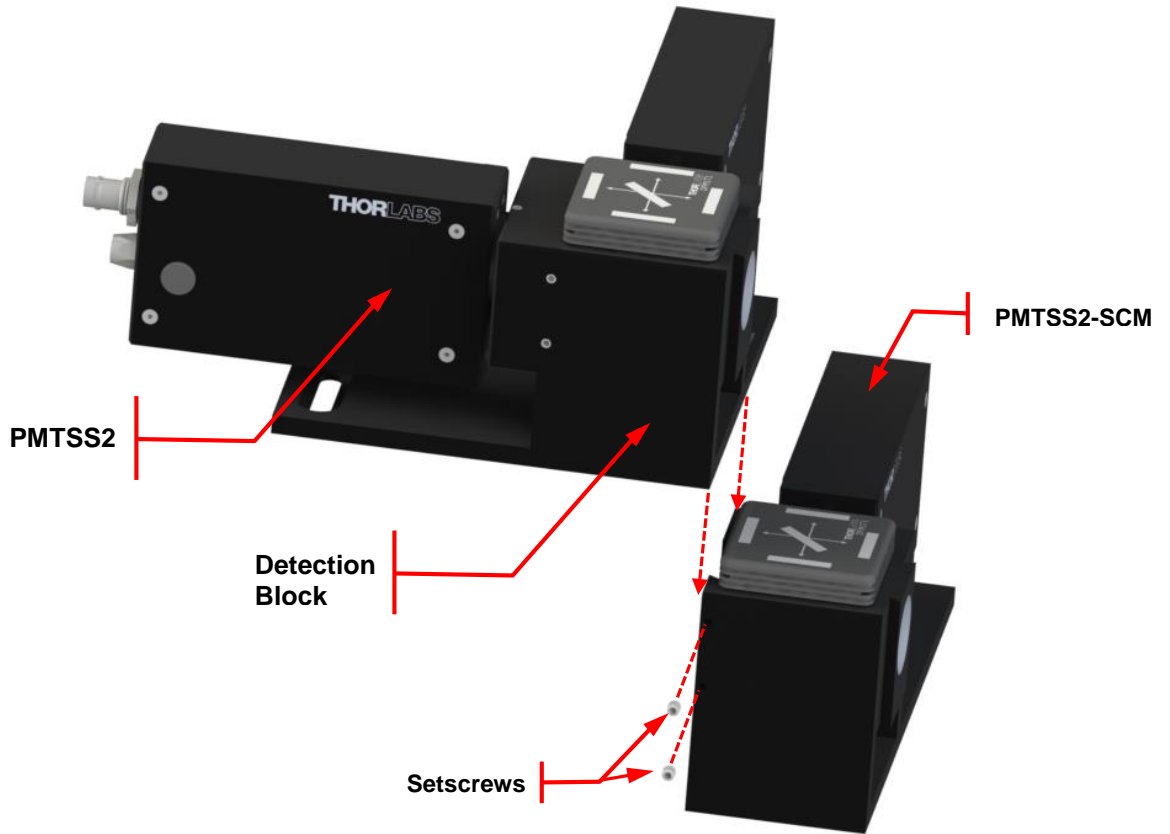

4. Use the 2 mm hex key to fasten the setscrews (2x) into the PMTSS2-SCM.



- Slide the PMT Face Plate onto the PMTSS2-SCM detection block.

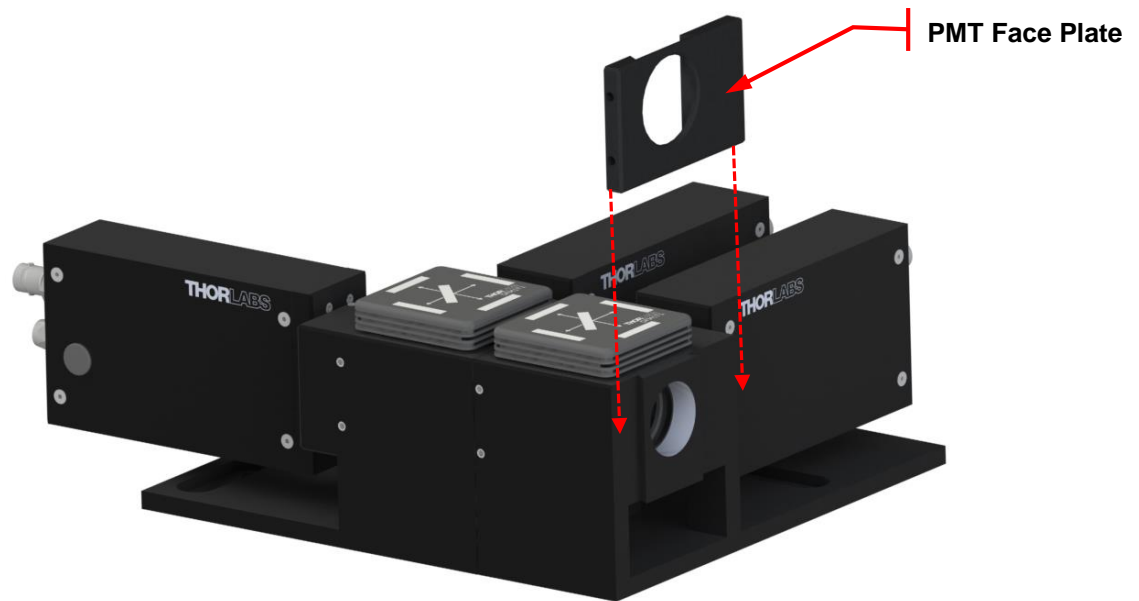

- Mount the Fiber Couple Lens Tube on the PMT Face Plate, and use the 2 mm hex key to fasten the setscrews into the PMT Face Plate.

The setscrews secure the Fiber Couple Lens Tube.



- Mount the unit on the optical table.
- Attach an SMA-terminated multimode fiber patch cable to the Fiber Couple Lens Tube.

Chapter 5 Maintaining the PMTSS Series

To clean the PMTSS/PMTSS2/PMTSS2-SCM:

- Use a soft, damp cloth to clean the housing.
- Use only optical grade wipes to clean the window of the tube.

There are no serviceable parts in the PMTSS series optical head. If you suspect a problem with the module, please contact Thorlabs by Phone: **973-300-3000** or email: **techsupport@thorlabs.com** for assistance from an applications engineer.

5.1. Storing the PMTSS Series

When not in use, store the PMTSS/PMTSS2/PMTSS2-SCM in an environment without light leakage or stray light.

Chapter 6 Connection and Programming

The following schematic drawings provide information on the general electrical connections and the protocol to program the PMTSS.

VOLTAGE PROGRAMMING

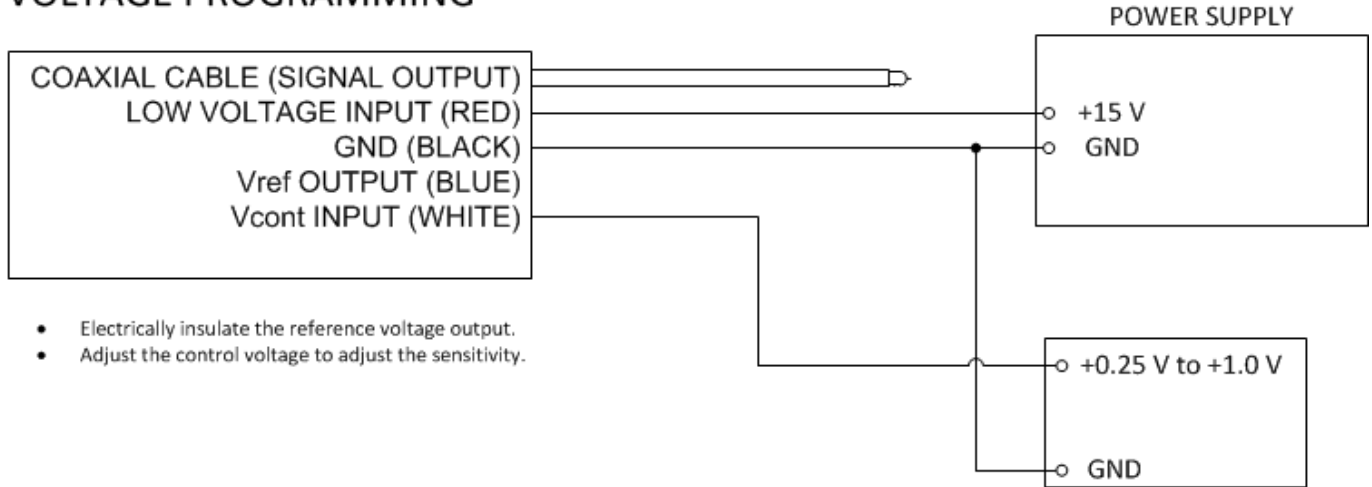

RESISTANCE PROGRAMMING

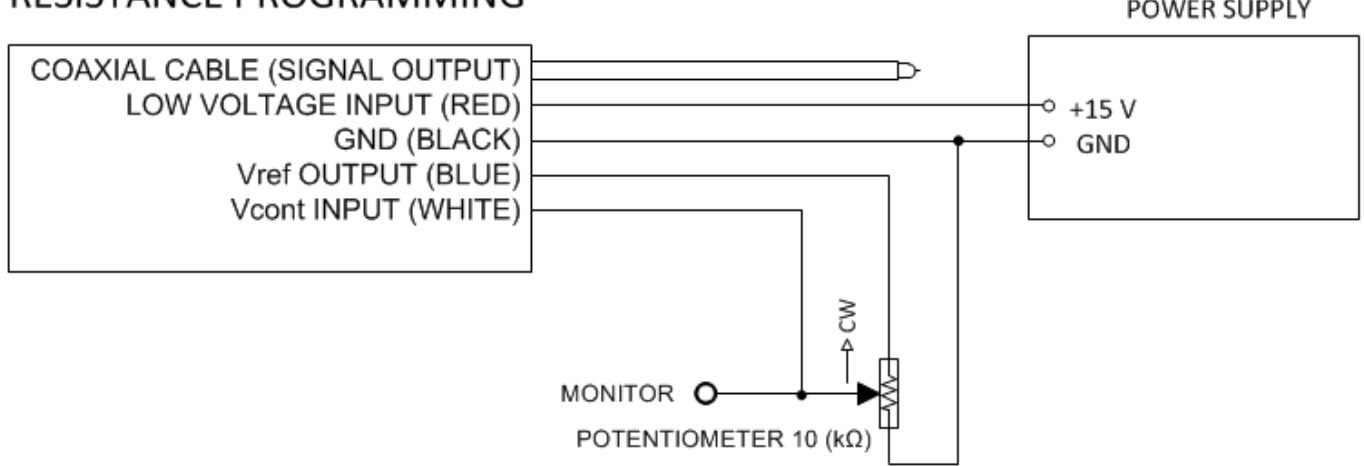

When using a potentiometer, adjust sensitivity, while monitoring the control voltage so that it does not exceed +12 V.

Figure 1 Voltage and Resistance Programming

Chapter 7 Performance Plots

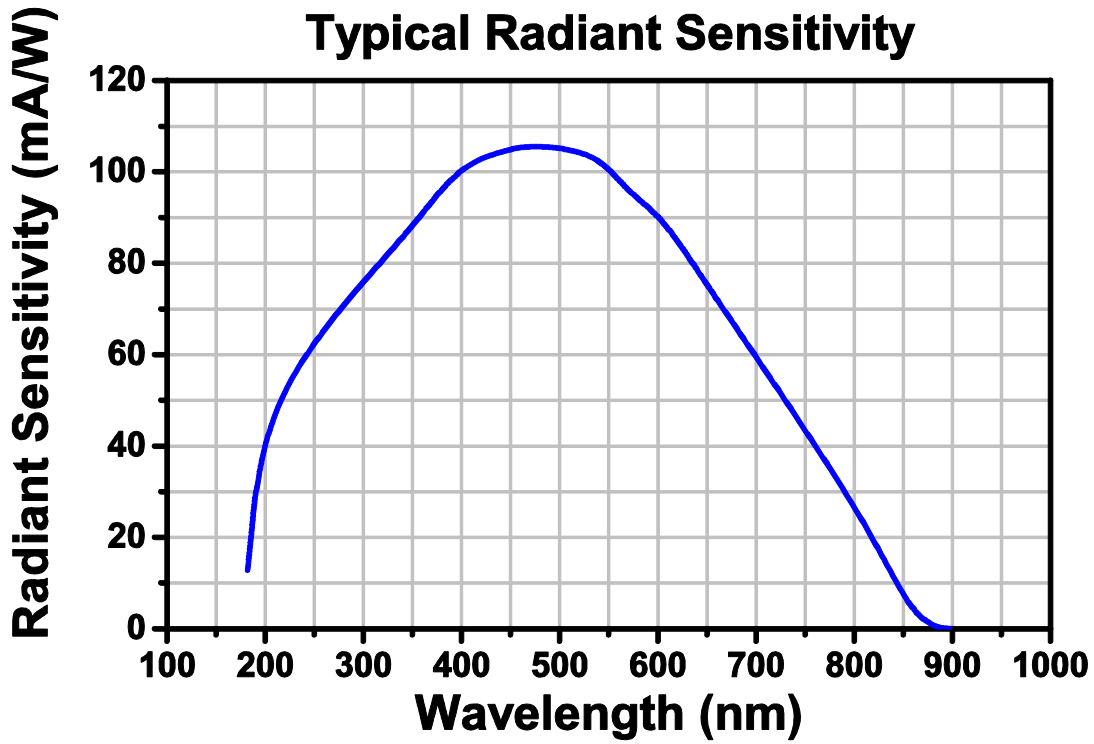

Figure 2 Cathode Radiant Sensitivity

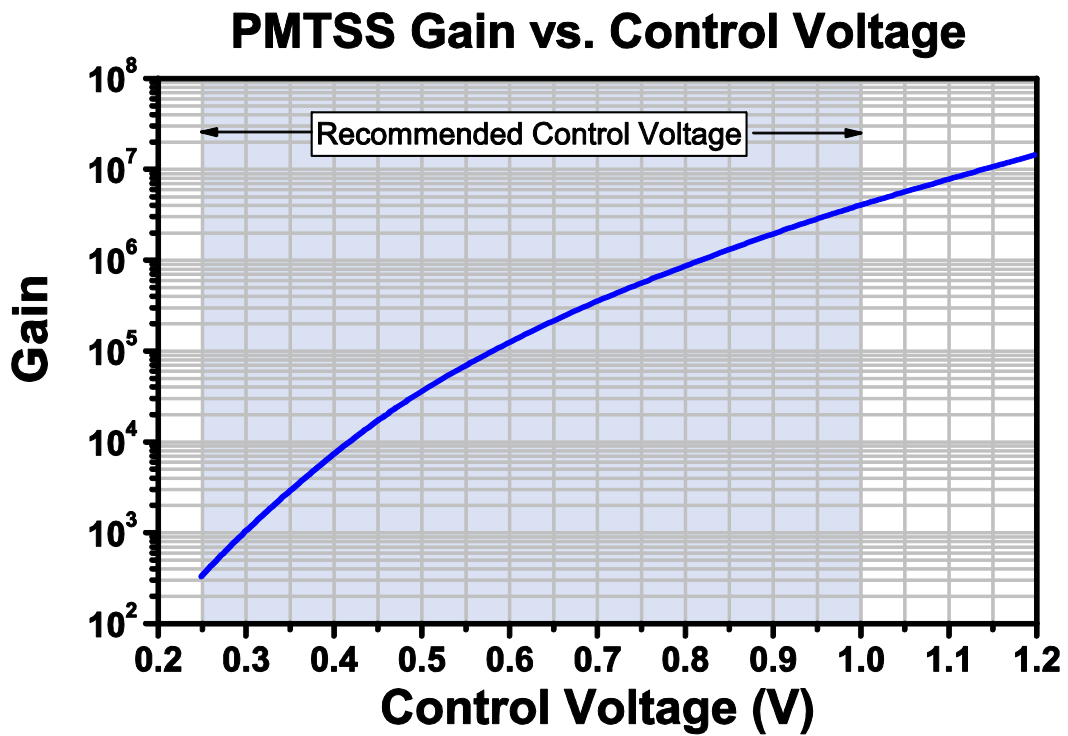

Figure 3 PMTSS Gain

Chapter 8 Specifications

8.1. General Specifications

Specification		Value
Module Dimensions	PMTSS	5.20" x 1.26" x 2.50" (132.0 mm x 32.1 mm x 63.5 mm)
	PMTSS2	10.18" x 8.09" x 3.40" (258.5 mm x 205.5 mm x 86.4 mm)
	PMTSS2-SCM	8.09" x 2.43" x 3.40" (205.5 mm x 61.8 mm x 86.4 mm)
Operating Temperature		+15 to +40 °C
Storage Temperature		-20 to +50 °C
Input Voltage		+ 15 V DC
Input Current (Max)		7 mA
Output Signal Current		10 µA (Max)
Weight	PMTSS	0.3 kg
	PMTSS2	1.4 kg
	PMTSS2-SCM	0.9 kg

8.2. Performance Specifications

Specification	Value
PMT Type	Multialkali
Photocathode Geometry	Side On
Spectral Response	185 – 900 nm
Peak Wavelength (λ_p)	450 nm
Radiant Sensitivity at λ_p^a (Typical)	105 mA/W
Quantum Efficiency at λ_p^a (Calculated)	>28%
Photocathode Active Area	0.15" x 0.51" (3.7 mm x 13.0 mm)
Dark Current	2.0 nA (Typical); 10 nA (Max)
Warm-Up Time Before Control Voltage ^b	30 – 60 minutes
Rise and Fall Time	1.4 ns
Settling Time ^c	10 s
Gain (Max)	>1.0 x 10 ⁷
PMT Voltage	+250 – 1000 V
PMT Control Voltage	+0.25 – 1.2 V via M8 x 1 Power Connector
Recommended Control Voltage Adjustment Range	+0.25 – 1 V
Window	UV-Transmitting Glass ($n = 1.48$)

a. Radiant Sensitivity (RS) is related to quantum efficiency (QE) by the following expression:

$$QE (\%) = \frac{RS (mA/W)}{\lambda (nm)} \times 124$$

b. The dark current rate specification is valid when the PMT has been turned on in the dark, no control voltage has been applied during the specified warm-up time, and no signal has been incident during the specified warm-up time.

c. The time required for the output to reach a stable level for control voltage adjustment from +1 V to +0.5 V.

Chapter 9 Mechanical Drawing

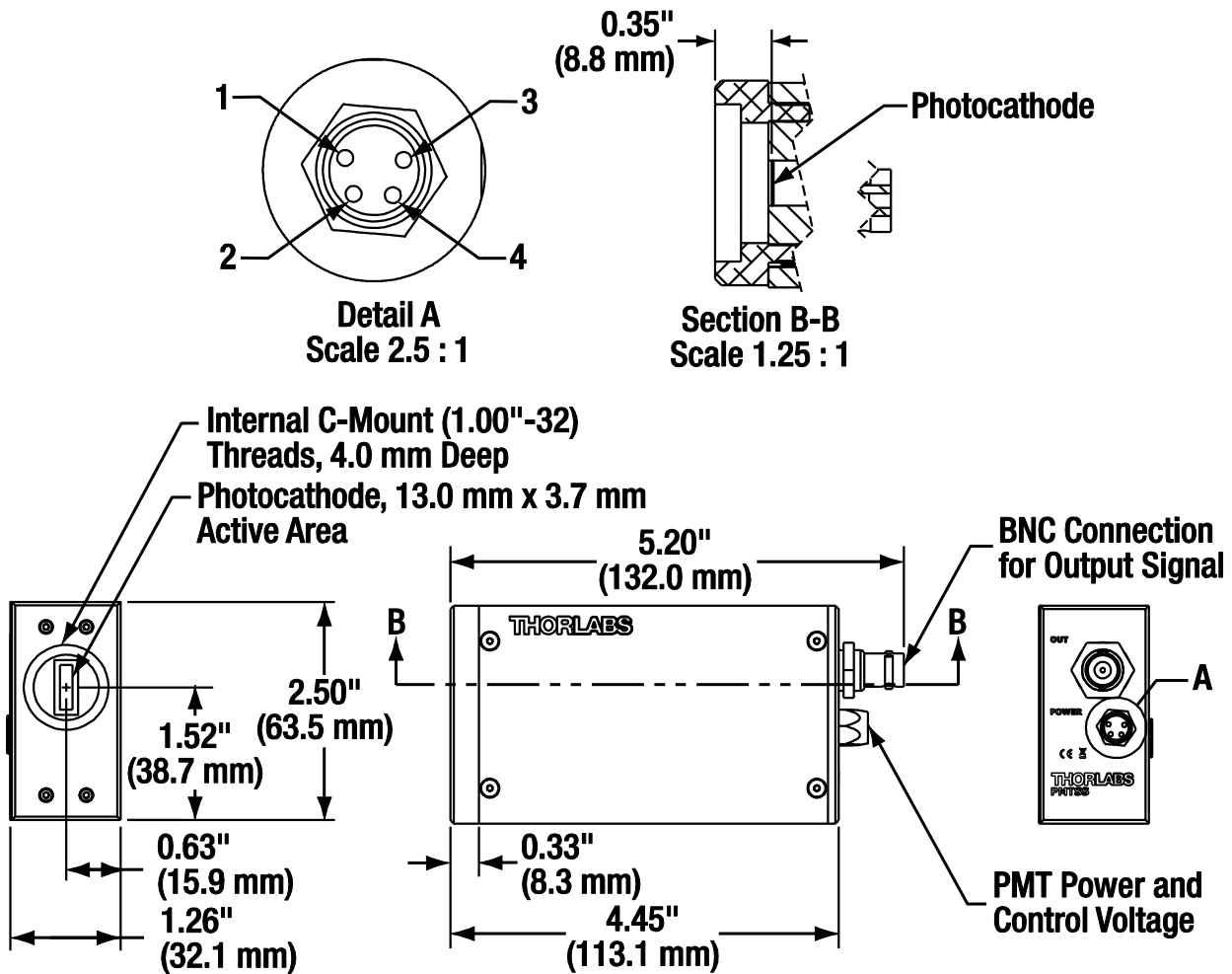

Pin	Description
1	V+ Power Supply Unit
2	V Control (0.25V to 1.2V)
3	No Connection
4	Ground Power Supply Return

Figure 4 Mechanical Drawing of the PMTSS Housing

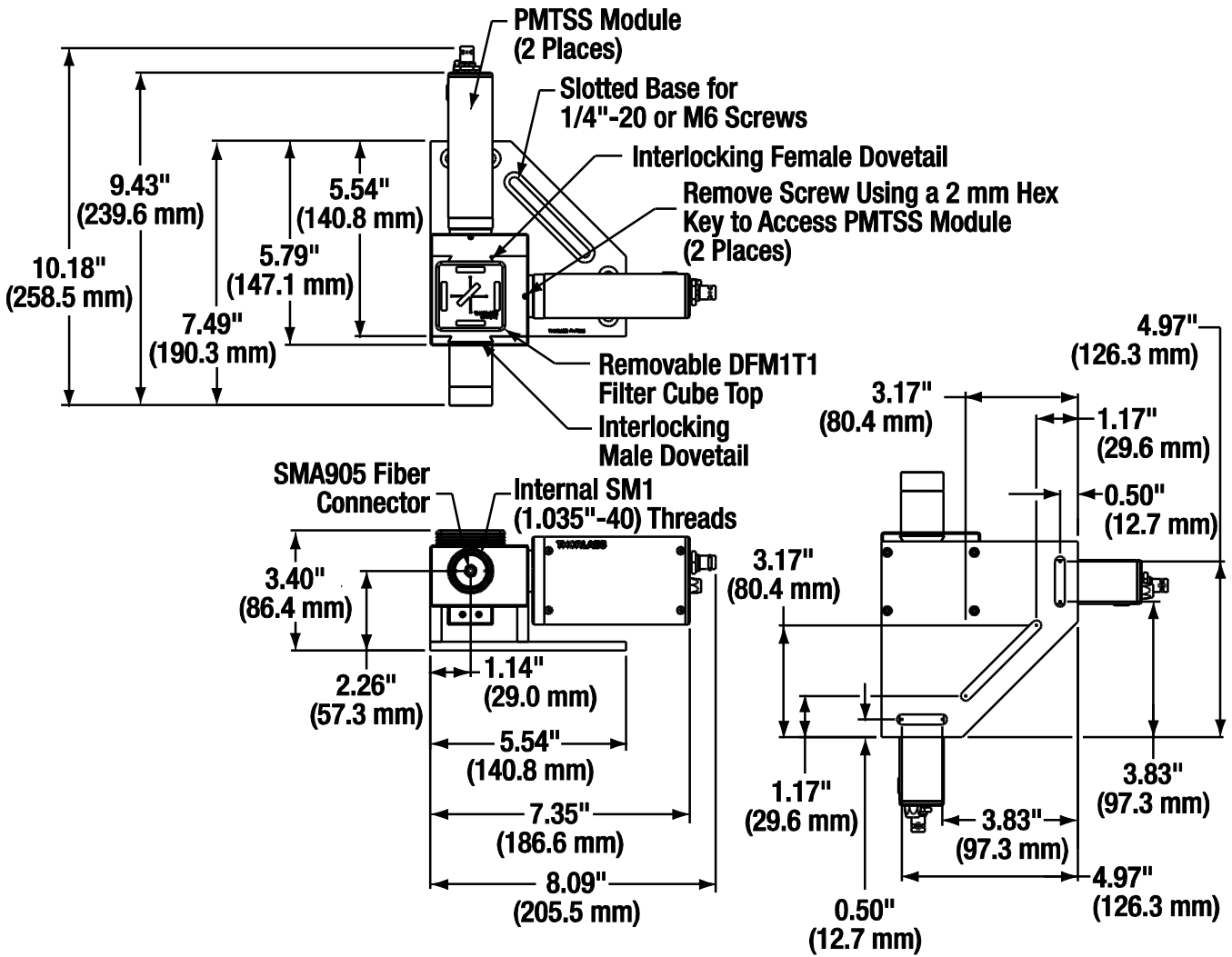

Figure 5 Mechanical Housing of PMTSS2 Housing

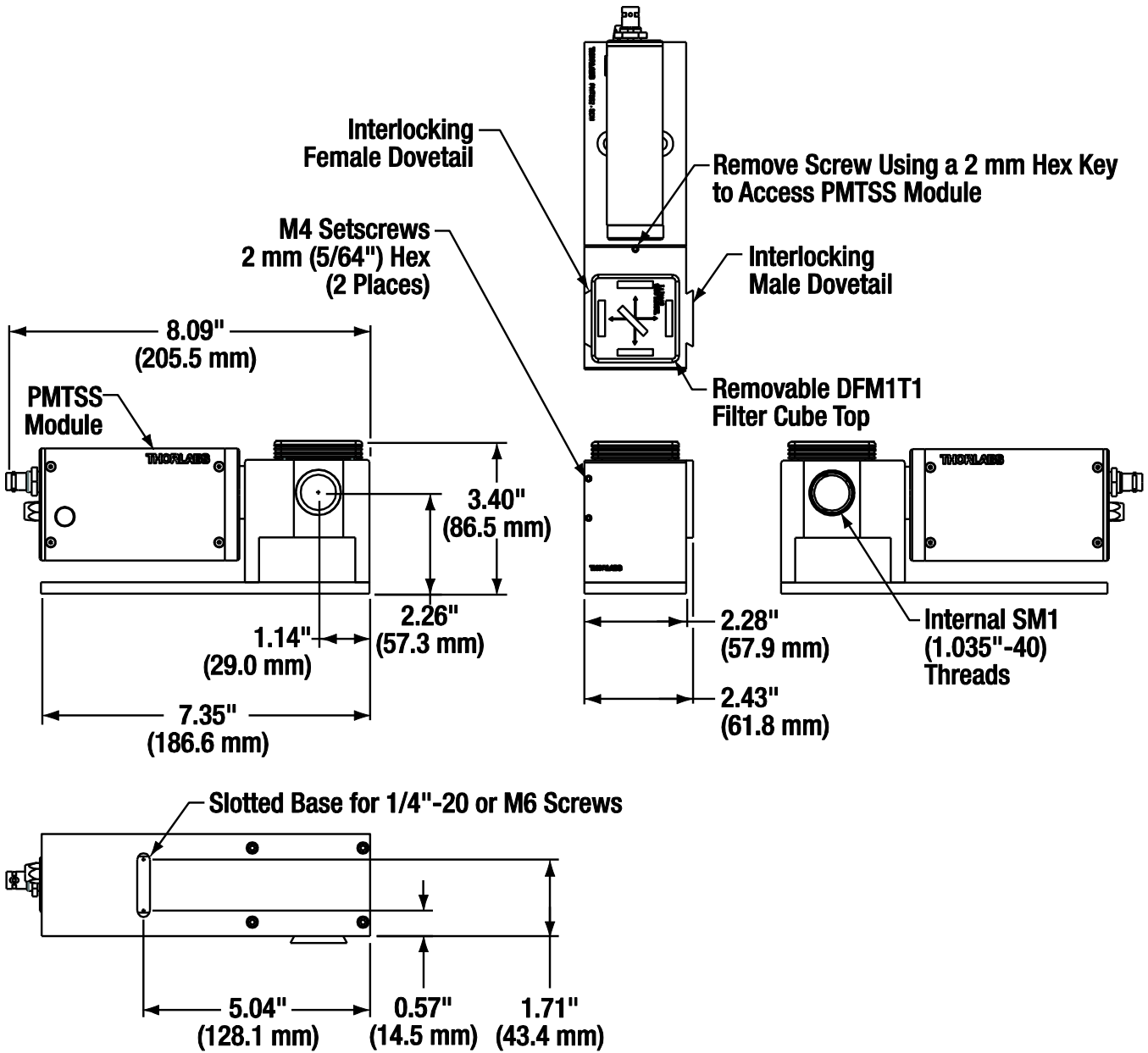
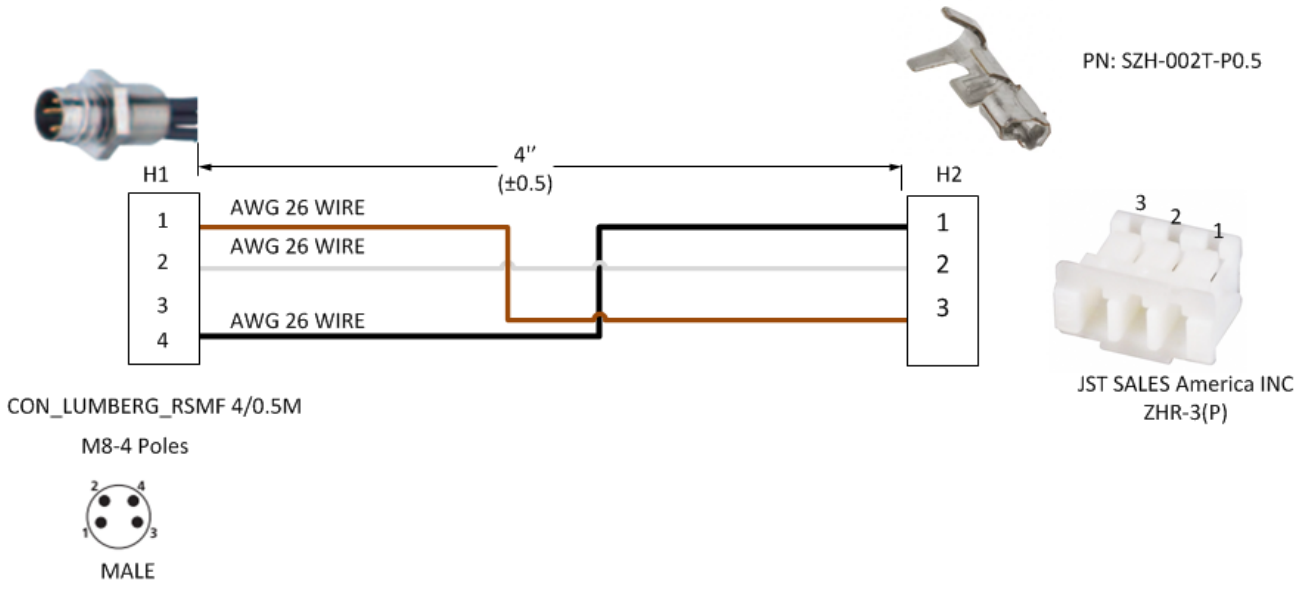

Figure 6 Mechanical Drawing of PMTSS2-SCM Housing

Chapter 10 Cable Wiring Diagram



H1	Signal	H2	Color
1	V+ Power Supply Input	3	BROWN
2	V Control (0.25 to 1.2V)	2	WHITE
3	No Connection	-	BLUE
4	GND Power Supply Return	1	BLACK

Figure 7 External Power Cable

Chapter 11 Certifications and Compliance



EU Declaration of Conformity
in accordance with EN ISO 17050-1:2010

We: Thorlabs Inc.
Of: 56 Sparta Avenue, Newton, New Jersey, 07860, USA

in accordance with the following Directive(s):

2014/30/EU	Electromagnetic Compatibility (EMC) Directive
2011/65/EU	Restriction of Use of Certain Hazardous Substances (RoHS)

hereby declare that:
Model: PMTSS and PMTSS-A

Equipment: Sensitivity PMT Module

is in conformity with the applicable requirements of the following documents:

EN 61326-1	Electrical Equipment for Measurement, Control and Laboratory Use - EMC Requirements	2013
------------	---	------

and which, issued under the sole responsibility of Thorlabs, is in conformity with Directive 2011/65/EU of the European Parliament and of the Council of 8th June 2011 on the restriction of the use of certain hazardous substances in electrical and electronic equipment, for the reason stated below:

is not subject to the Directive, but nevertheless, based on certifications received from our vendors, does not contain substances in excess of the maximum concentration values tolerated by weight in homogeneous materials as listed in Annex II of the Directive.

I hereby declare that the equipment named has been designed to comply with the relevant sections of the above referenced specifications, and complies with all applicable Essential Requirements of the Directives.

Signed:  **On:** 22 August 2016

Name: Ann Strachan
Position: Compliance Manager

CE
EDC - PMTSS and PMTSS-A -2016-08-22

Chapter 12 Warranty

Thorlabs warrants that all products sold by Thorlabs will conform to the published specifications and shall be free from defects in material and workmanship under normal use, handling, and service.

Thorlabs provides the warranty stated by the PMT manufacturer.

Chapter 13 Regulatory

As required by the WEEE (Waste Electrical and Electronic Equipment Directive) of the European Community and the corresponding national laws, Thorlabs offers all end users in the EC the possibility to return “end of life” units without incurring disposal charges.

This offer is valid for Thorlabs electrical and electronic equipment:

- Sold after August 13, 2005
- Marked correspondingly with the crossed out “wheelie bin” logo (see right)
- Sold to a company or institute within the EC
- Currently owned by a company or institute within the EC
- Still complete, not disassembled and not contaminated

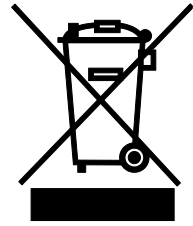

Wheelie Bin Logo

As the WEEE directive applies to self-contained operational electrical and electronic products, this end of life take back service does not refer to other Thorlabs products, such as:

- Pure OEM products, that means assemblies to be built into a unit by the user (e. g. OEM laser driver cards)
- Components
- Mechanics and optics
- Left over parts of units disassembled by the user (PCB's, housings etc.).

If you wish to return a Thorlabs unit for waste recovery, please contact Thorlabs or your nearest dealer for further information.

13.1. Waste Treatment is Your Own Responsibility

If you do not return an “end of life” unit to Thorlabs, you must hand it to a company specialized in waste recovery. Do not dispose of the unit in a litter bin or at a public waste disposal site.

13.2. Ecological Background

It is well known that WEEE pollutes the environment by releasing toxic products during decomposition. The aim of the European RoHS directive is to reduce the content of toxic substances in electronic products in the future.

The intent of the WEEE directive is to enforce the recycling of WEEE. A controlled recycling of end of life products will thereby avoid negative impacts on the environment.

Chapter 14 Thorlabs Worldwide Contacts

For technical support or sales inquiries, please visit us at www.thorlabs.com/contact for our most up-to-date contact information.



USA, Canada, and South America

Thorlabs, Inc.
sales@thorlabs.com
techsupport@thorlabs.com

Europe

Thorlabs GmbH
europe@thorlabs.com

France

Thorlabs SAS
sales.fr@thorlabs.com

Japan

Thorlabs Japan, Inc.
sales@thorlabs.jp

UK and Ireland

Thorlabs Ltd.
sales.uk@thorlabs.com
techsupport.uk@thorlabs.com

Scandinavia

Thorlabs Sweden AB
scandinavia@thorlabs.com

Brazil

Thorlabs Vendas de Fotônicos Ltda.
brasil@thorlabs.com

China

Thorlabs China
chinasales@thorlabs.com



THORLABS
www.thorlabs.com
