

NOTES:

1. SUBSTRATE: GRADE A FINE ANNEALED  
SCHOTT: N-BK7 517/642
2. ROHS COMPLIANT
3. SURFACE S2 TO BE PARALLEL TO SURFACE S1 TO WITHIN 3 ARCMIN
4. COATING (APPLY ACROSS COATING APERTURE)  
SPECIFICATIONS AT 45° AOI AND RANDOM POLARIZATION  
S1:  
 $R(\text{abs}) = 30\% \pm 5\% @ 550\text{nm}$   
 $R(\text{abs}) = 30\% \pm 10\% \text{ FROM } 400\text{-}700\text{nm}$   
 $T(\text{abs}) = 70\% \pm 5\% @ 550\text{nm}$   
 $T(\text{abs}) = 70\% \pm 10\% \text{ FROM } 400\text{-}700\text{nm}$   
 VISUAL COLOR = NEUTRAL

S2: BBAR  
 $R(\text{abs}) \leq 2.0\% \text{ FROM } 400\text{-}700\text{nm}$   
 $R(\text{avg}) \leq 1.0\% \text{ FROM } 400\text{-}700\text{nm}$



FINE GRIND SURFACE



MARK IDENTIFIES BEAMSPLITTER SURFACE

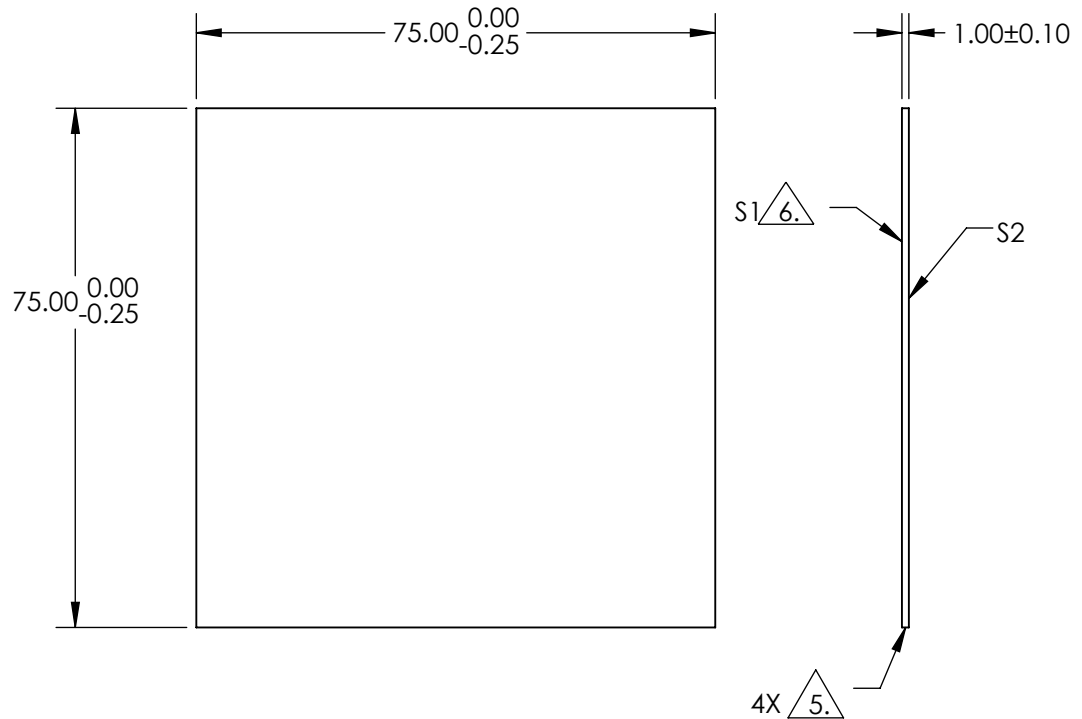

**FOR INFORMATION ONLY:  
DO NOT MANUFACTURE  
PARTS TO THIS DRAWING**

SPECIFICATIONS SUBJECT TO CHANGE WITHOUT NOTICE  
DIMENSIONS ARE FOR REFERENCE ONLY

	S1	S2
SHAPE	PLANO	PLANO
SURFACE FLATNESS	1λ PER 25mm	1λ PER 25mm
SURFACE QUALITY	60 - 40	60 - 40
MIN CLEAR APERTURE	63.75 x 63.75	63.75 x 63.75
MIN COATING APERTURE	63.75 x 63.75	63.75 x 63.75
BEVEL	PROTECTIVE AS NEEDED	PROTECTIVE AS NEEDED

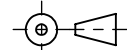
THIRD ANGLE PROJECTION 

ALL DIMS IN mm

**EO**® Edmund Optics®

TITLE: BS VIS 30R/70T 75X75MM 1MM THK

DWG NO: 35939

SHEET 1 OF 1