

1:1 ISOMETRIC VIEW

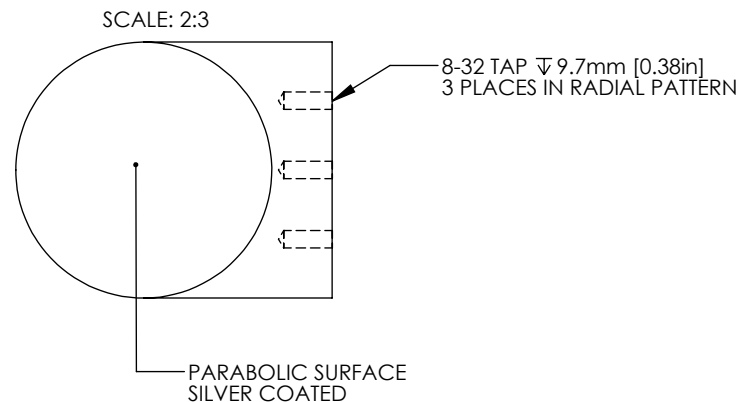
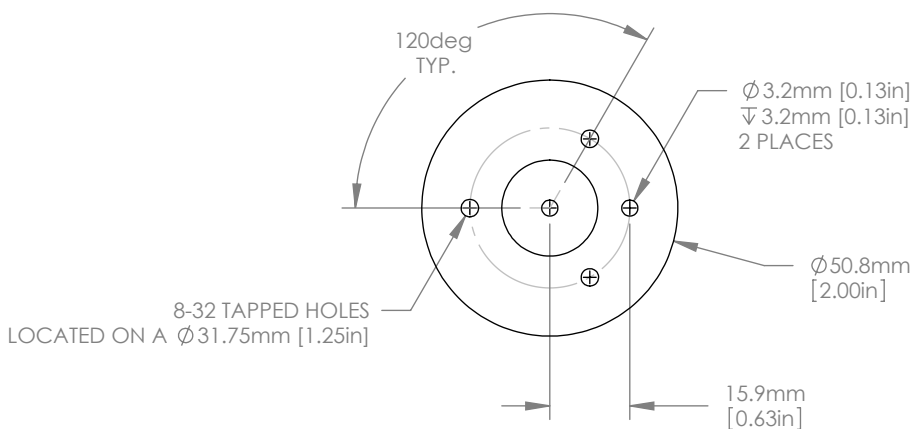

NOTES/SPECIFICATIONS:

1. PFL(PARENT FOCAL LENGTH): 76.2mm ±1%
2. REFLECTED FOCAL LENGTH: 152.4mm ±1%
3. CLEAR APERTURE: >90% OF DIAMETER
4. SURFACE IRREGULARITY: 0.25λ @ 633nm
5. SURFACE QUALITY: 40-20 SCRATCH-DIG
6. SURFACE ROUGHNESS: <100A RMS
7. COATING (PARABOLIC SURFACE): PROTECTED SILVER
Ravg>95% FROM 400nm-20μm
8. BLACK ANODIZED FINISH (NON-OPTICAL SURFACES)

FOR INFORMATION ONLY
NOT FOR MANUFACTURING PURPOSES

DRAWING PROJECTION			THORLABS www.thorlabs.com	
NAME	DATE			
DRAWN	MG	18/AUG/11	Ø 50.8mm 90° OFF AXIS PARABOLA PFL=76.2mm, PROTECTED SILVER	
APPROVAL	DD	07/SEP/11	MATERIAL	REV
COPYRIGHT © 2010 BY THORLABS			6061-T6 ALUMINUM	A
VALUES IN PARENTHESIS ARE CALCULATED AND MAY CONTAIN ROUND OFF ERRORS			ITEM #	APPROX WEIGHT
			MPD508762-90-P01	0.01 kg