

OUTPUT (BNC): 0-10 V max. POWER CONNECTOR

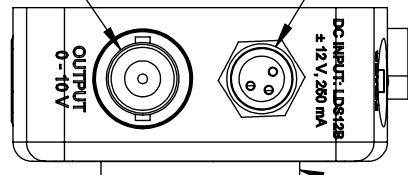

DETECTOR ACTIVE AREA SURFACE IS FLUSH WITH FRONT OF HOUSING

SM1 (1.035-40) SERIES EXTERNAL THREAD



0.04in [1.1mm]

0.09in [2.2mm]

2.07in [52.5mm]
1.96in [49.9mm]

1.09in [27.7mm]

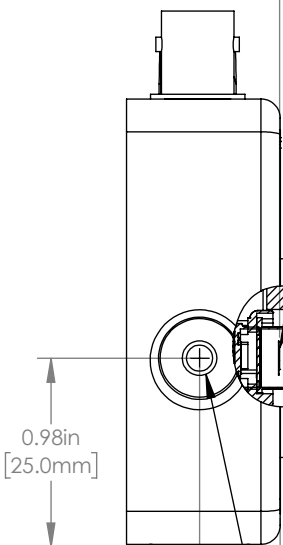

Ø 3.0mm DETECTOR

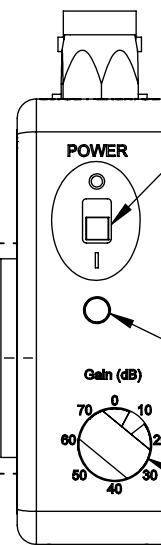
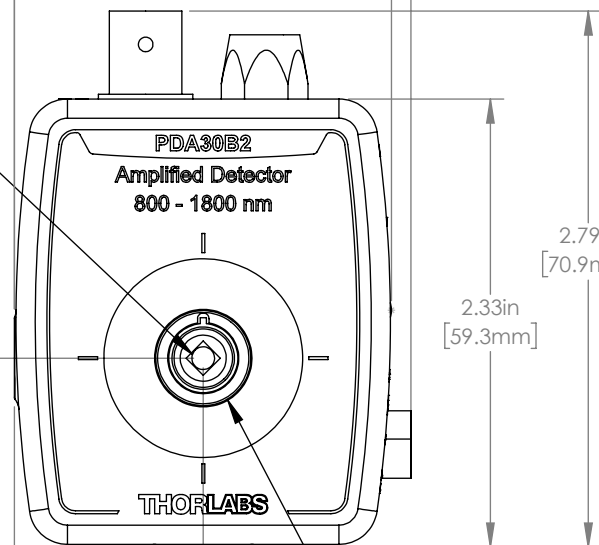

POWER SWITCH

POWER INDICATOR LED

8 POSITION ROTARY GAIN SWITCH

INCLUDED:
SM1 ADAPTER and
SM1RR RETAINING RING

0.98in [25.0mm]

0.98in [25.0mm]

SM05 (0.535-40) SERIES INTERNAL THREAD

0.51in [12.8mm]

0.80in [20.3mm]

0.89in [22.5mm]

THREAD MOUNTS ACCEPT:
8-32 x 0.25in
AND M4 x 0.7 x 6mm

0.98in [25.0mm]

0.98in [25.0mm]

FOR INFORMATION ONLY
NOT FOR MANUFACTURING PURPOSES

DRAWING PROJECTION



	NAME	DATE
DRAWN	WKC	08/DEC/17
APPROVAL	RH	08/DEC/17

COPYRIGHT © 2017 BY THORLABS

VALUES IN PARENTHESIS ARE CALCULATED AND MAY CONTAIN ROUND OFF ERRORS

THORLABS
www.thorlabs.com

Ge Adjustable Gain Detector

MATERIAL N/A REV B

ITEM # PDA30B2 APPROX WEIGHT 0.10 kg