

Rev.	Description	Drawn	Date	Appr.
------	-------------	-------	------	-------

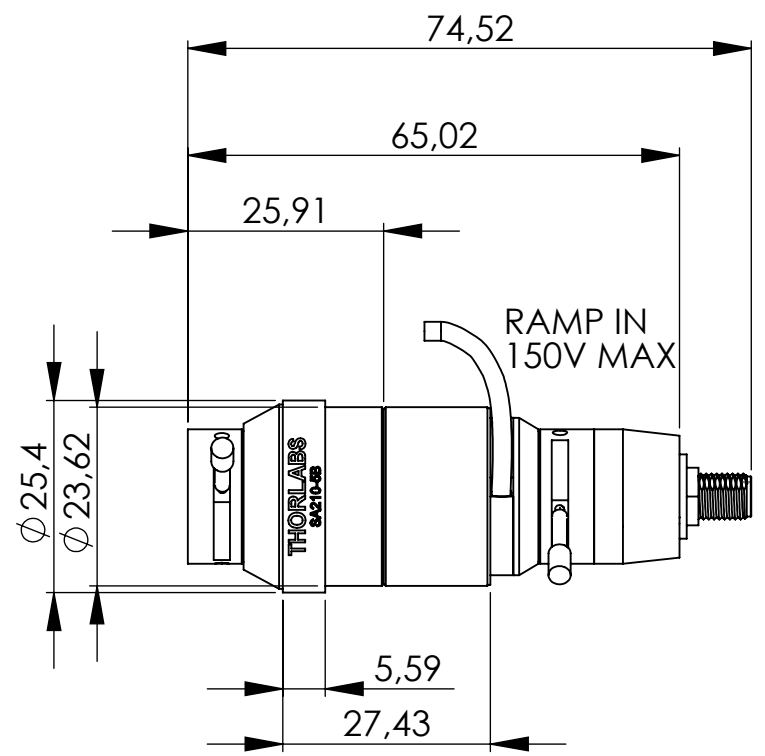

SMA OUTPUT
PHOTODIODE
CURRENT TO
SA201 OR SCOPE

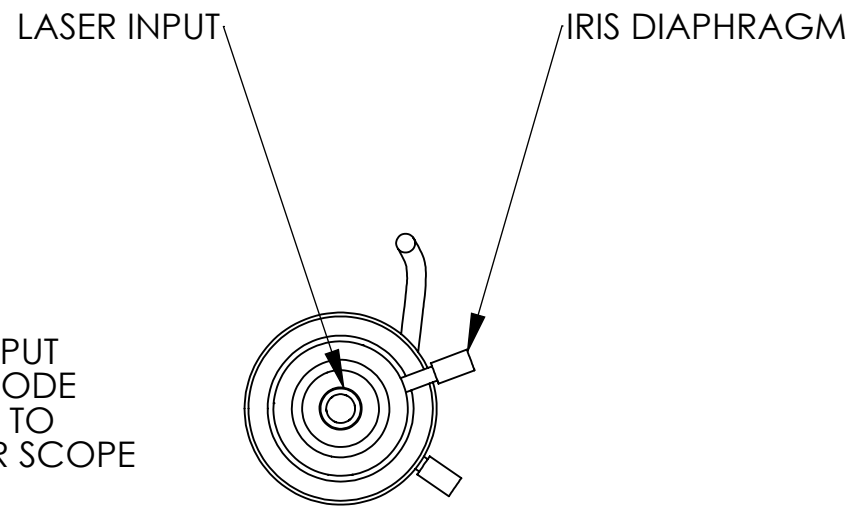

INFORMATION ONLY, NOT FOR MANUFACTURING

Surface Treatment		Material		General Tolerance SS ISO-2768 fH		Weight 90 g	
Design	Drawn	Check	Sheet 1/1	Sheet Format A4	Scale 1:1		Rev. A
THORLABS Sweden AB Tel: +46 31 733 3000 Box 14194 Fax: +46 31 703 4045 SE-400 20 Göteborg		Scanning Fabry Perot 535-820nm SA210-5B, 10GHz FSR					Date 2009-10-20 Drawing no. 19503-E01

This drawing must not without our permission be copied, im-
 ported to a third party or otherwise used without authorisation.
 Contrainvention will be prosecuted.

Denna handling är Thorlabs Sweden AB's egendom
 och får ej utan vårt medgivande kopieras, delges
 annan eller obehörigen användas.