

F9J "	89G7 F-DHC B.	B5A 9#85H9.

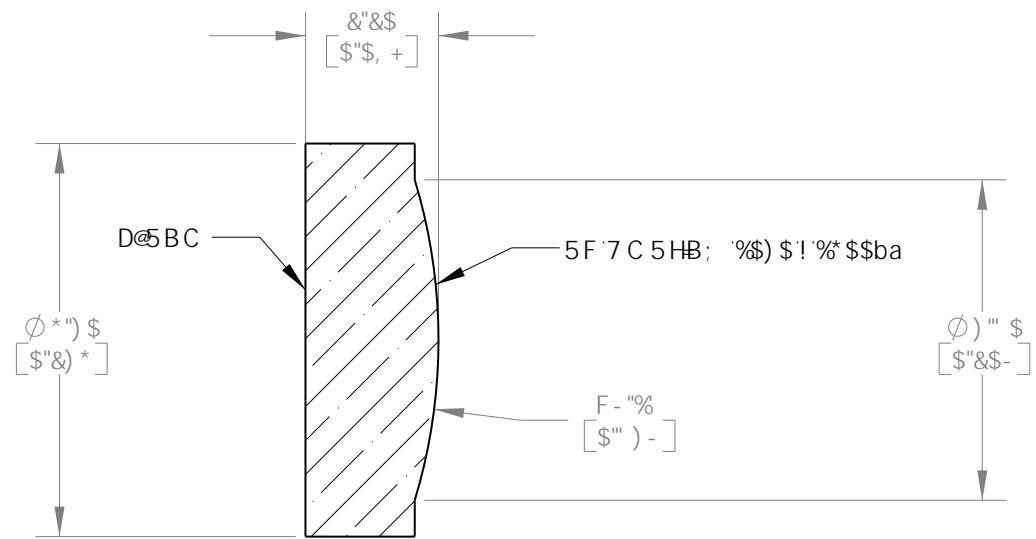
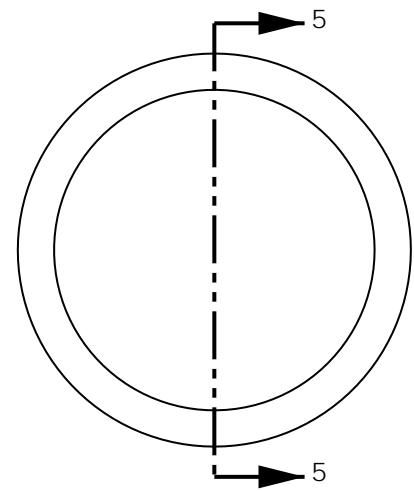
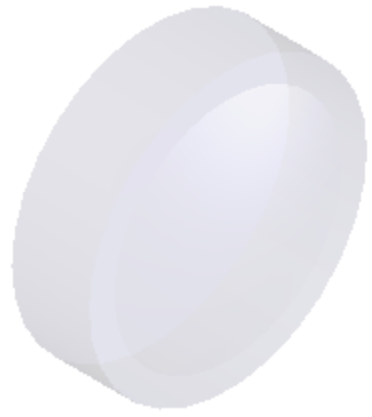

GD97 ÷ 7 5HC BG

89G ÷ B K 5J 9@B; Hk. +, \$ba
 BI A 9F 7 5@5D9FH F9: \$"%*
 7 @5F 5D9FH F9.) "\$\$a a
 9: 97 HJ 9: C 7 5@B; Hk. % "&- 'a a
 A 5; B ÷ 7 5HC B; B: B +9
 FA GK : 9. 0 8 ÷: " @A #1
 K CF? B; ' 8 G 5B 7 9. % (" \$a a

: CF B: CFA 5HC B CB @M
 BCH BH9B 898 : CF A 5BI : 57 H F B;

HC @F 5B 7 9G	B5A 9	85H9
1 B @9GGCH: 9FK @9 GD97 ÷ 98.	8F5K B	8D
8-A 9B GC BG 5F 9-B A @A 9 FFG	9B: '5DDF"	?A G
@B 95F HC @F 5B 7 9G	A:: '5DDF"	HC
...CB9D@579897-A 5@±\$&	DFC DF-9 5FM 5B 8 7 CB: 8 9B H 5@	
...HK C D@579897-A 5@±\$&(\$	H: 9 B: CFA 5HC B 7 C B H 5 B 98 B H: 6	
5B: 1 @F. ±' \$π"	8F5K B: 'GH: 9GC @9 DFC D9F HMC:	
	H: C F @5 6G 2 B 7 " 5 B M F 9 D F C 8 I 7 H C B	
	B D5F H C F 5 G 5 K < C @ K + C I H	
	H: 9 K F # H 8 D 9 F A 6 G C B C:	
	H: C F @5 6G 2 B 7 " 6 D F C < 6 + 9 8 "	

Hk C F @ 5 6G 2 B 7 "		DC '6CL" **
		B 9K HC B B >
H# @.		
5 GD < 9F 7 ' @ 9 B G Z 1 %) "&- 'a a 'B 5 ' 1 '\$ %"		
A 5 H 9 F 5 @	G 4 9	F 9 J "
7 C F B B; ; @ 5 G G 7 \$)) \$	5	5
G 7 5 @, . %	G < 9 9 H % C : %	
8 K ; " " BC "	D 5 F H B C "	
\$ -)) 1 9 \$ %	') \$ & * \$ 1 7	