

F9J "	89G7 F-DHC B.	B5A 9#85H9.

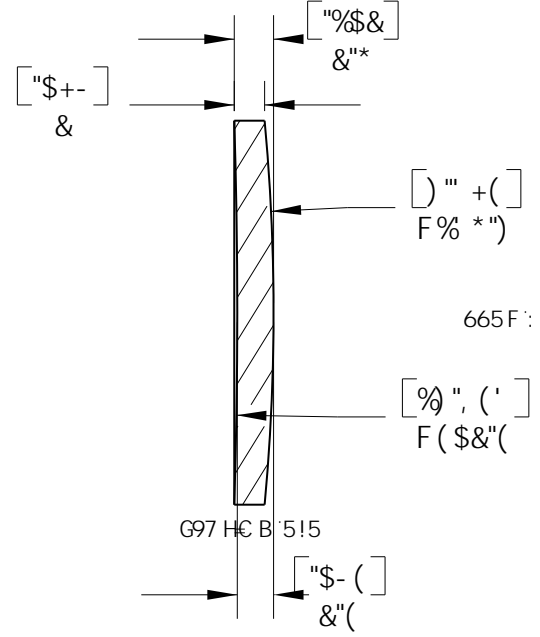
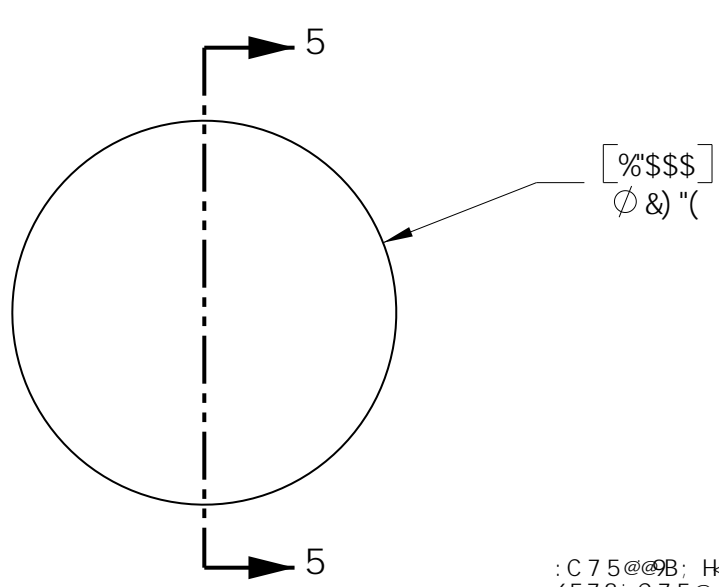

:C 75@@B; Hk. (\$"\$a a
657?: C 75@ ' -+*"a a
B89L. %)%) '4 *'' ba
89G= B'K 5J 9@B; Hk. *'' ba
G7 F5H7 <#8= .(' \$&\$
8-5A 9H9F HC @F5B79. Z"\$a a #"\$a a
7 @95F '5D9FH F9. O- \$i
7 9BH9F HC B. ' 5F7 'A B
7 9BH9F Hk-? B9CGHC @F5B79. -"\$a a
7 <5A: 9F '\$&\$a a '5H(') \$5@G<5FD'98; 9G
98: 9Hk-? B9CG5GG A B; G<5FD'98; 9
5B8; 9B '69. C F97 <5A: 9F

BCH9.
:CF B: CFA 5HCB CB@M
BCH: CFA 5BI : 57H F-B;

5@! B+G; 9B B'A @A 9HFG
5B8 B7 <9G

HC@F5B79G	B5A 9	85H9
1 B@9GCH:9FK @9 GD97 =98.	8F5K B	5D)#& #&\$*\$
8-A 9BGCBG5F9-B B7 <9G	9B: '5DDF"	HC)#& #&\$*\$
@B95F HC@F5B79G	A:: '5DDF"	HC)#& #&\$*\$
...HK C D@57 9897-A 5@ ±\$"\$%	DFC DF-96FM5B87CB: B9BH5@	
...H:F99D@57 9897-A 5@ ±\$"\$%	H:9 B: CFA 5HCB 7CBH5B98 B Hk-G	8F5K B: G H:9GC @DFC D9FHMC:
5B: 1 @F. ±' \$H	H:C F@56Gz-B7 "5BMF9DFC 8I 7HC B	B D5FHC F 5G5 K <C @K H:C I H
GI F: 579: B-G<." &A =FC-B7 <9G	H:9K F#H9B D9FA GGC B C:	H:C F@56Gz-B7 "GDFC <+98"
D5F5 @9@CA. "\$\$\$&		
: @HB9CG "\$\$\$&		
GF5 = <HB9CG "\$\$\$&		
7CB7 9BH F=7 HM "\$\$\$&		
D9FD9B 8-71 @FHM "\$\$\$&		
H:F958. 7 @GG&: H		

Hk C F @5 6G B 7 " DC '6CL" **	
B9K HC B B>	
H#@.	
« &)"(a a '6?+ 'DC G+H 9'A 9B @7I G @9B G	
A 5H9F 5@	G#9 F9J "
6?+Z: fUXY '5	5 5
G7 5@. %%	G<99H% C: %
8K ; "BC "	D5FH'BC "
(, &\$!9\$%	@% +&!5