

F9J "	89G7 F-DHC B.	B5A 9#85H9.

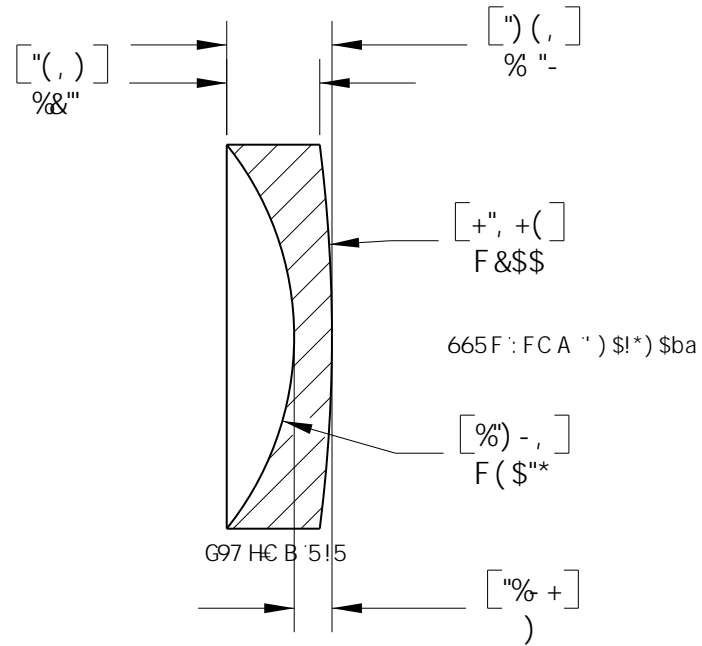
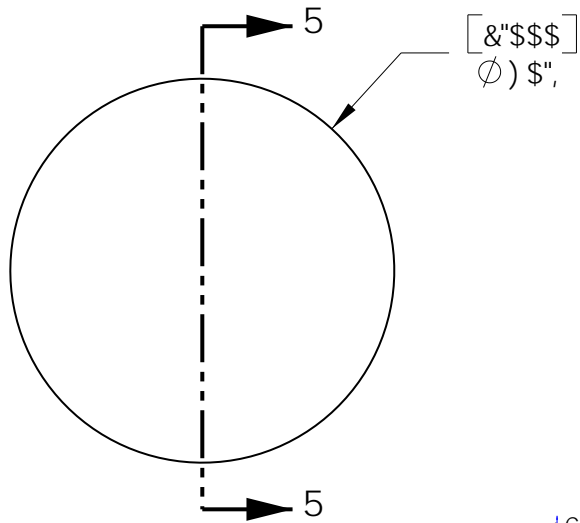

*C 75@@B; Hk. !%\$\$"\$a a
657?: C 75@ !- -"&a a
B 89L. %)%) '4 '* ' ' ba
89G= B 'K 5J 9@B; Hk. '* ' ' ba
G7 F5H7 <#8 = '(\$&\$
8-5A 9H9F 'HC @F5B79. Ž\$"\$a a # \$"%\$a a
7 @95F '5D9FH F9. O- \$i
7 9BHF5HC B. " '5F7 'A B
7 9BH9F 'Hk-7? B9CG'HC @F5B79. '-\$"%a a
7 <5A: 9F '\$"&\$a a '5H(') \$'5@G<5FD'98; 9G
98: 9Hk-7? B9CG'5GGI A B; 'G<5FD'98; 9
5B8; = 9B '69. C F97 <5A: 9F

BCH9.

: CF 'B: CFA 5HC B 'CB@M
BCH: CF 'A 5BI : 57H F-B;

5@@I B+G; = 9B 'B 'A @A 9HFG

HC @F5B79G	B5A 9	85H9
I B@XGC H: 9FK @9 GD97 = 98.	8F5K B	5D) #8) #&\$\$*
8-A 9BGC BG5F9-B 'B7 <9G	9B: '5DDF"	HC) #8) #&\$\$*
@B95F 'HC @F5B79G	A: ; '5DDF"	HC) #8) #&\$\$*
" "Hk C D@579897-A 5@ ±\$"\$%	DFC DF-96FM5B87CB: B9BH5@	
" "Hk F99D@579897-A 5@ ±\$"\$%	Hk-9 B: CFA 5HC B '7CBH5-B98-B Hk-6	
5B: 1 @5F. '±' \$F"	8F5K B: '6Hk-9GC @DFC D9FHMC:	
GI F: 579: B-G<." &A =7FC-B7 <9G	HkC F@56Gz-B7 "5BMF9DFC 8I 7HC B	
D5F5 @9@CA. '\$\$\$&	B D5FHCF 5G5 K <C @K HkC I H	
: @5HB9CG '\$\$\$&	Hk-9K F H9B 'D9FA @GC B C:	
GF5 = <H9CG '\$\$\$&	HkC F@56Gz-B7 "4DFC <6+98"	
7CB7 9BHF-7 HM '\$\$\$&		
D9FD9B8-7I @5F+M '\$\$\$&		
Hk F958. 7 @5GG&: #I		

Hk C F @56Gz-B7 " DC '6CL" ** B9K HC B 'B >	
Hk @.	
«) \$", a a '6? + 'B9; 5HJ 9'A 9B-G7I G@9B G	
A 5H9F 5@ 6? +ž: fUXY '5	G@9 F9J " 5 5
G7 5@. %%	G<99H% C: %
8K; "'BC" (, +, !9\$%	D5FH'BC " @%+*(15

)

(

&

%