

Motorized Filter Wheel 88398 / 88171



Edmund Optics Inc.
101 East Gloucester Pike
Barrington, NJ 08007-1380 USA

Tel: 856-547-3488
US Toll Free: 800-363-1992
Fax: 856-573-6295
www.edmundoptics.com

PRODUCT IDENTIFICATION

Part Number: _____

Serial Number: _____

Date Tested: _____

Motorized Filter Wheel 88398 / 88171

TABLE OF CONTENTS

1. DESCRIPTION	3
2. SUPPLIED EQUIPMENT	3
3. FEATURES	3
4. SPECIFICATIONS	4
Electrical	4
Mechanical	4
Physical	4
Mechanical Drawings	5
5. OPERATION	6
Mounting	6
Power	7
Aperture	7
Manual Control	7
Installing Filters	7
Capacity Switch	7
6. SOFTWARE	8
Manual Interface	8
Serial Communications	8
Data Format	9
Codes	10
8. REGULATORY	11
9. EC DECLARATION OF CONFORMITY	12
10. LIMITED WARRANTY	13

DESCRIPTION

Stepper Motor driven and Optical Encoder regulated, Edmund Optics's Motorized Filter Wheel is designed to repeatedly select absolute positions upon manual push button command or remotely through the RS-232 or USB 2.0 interface. It has two aperture positions at 12:00 and 9:00, can accommodate up to six 1" (25mm) filters on interchangeable filter retaining wheels, and features a digital display on the unit that reads the current filter position. An optional twelve position filter retaining wheel which holds up to twelve 1/2" (12.5mm) filters is also compatible with the unit and easily installed.

SUPPLIED EQUIPMENT

- 1 88398 (12.5mm Filter Wheel)
- 1 5V DC Converter
- 1 USB 2.0A to USB Micro A (6ft Cable)
- 1 RS-232 to RS-232 (6ft Cable)
- 1 Software Flash Drive
- 2 Threaded Aperture Caps
- 12 Threaded 1/2" Filter Retaining Rings
- 1 5/64" Ball Driver
- 1 Operating Manual
- 2 Aperture Reducing Caps

OR

- 1 88171 (25mm Filter Wheel)
- 1 6 Position Filter Retaining Wheel
- 1 5V DC Converter
- 1 USB 2.0A to USB Micro A (6ft Cable)
- 1 RS-232 to RS-232 (6ft Cable)
- 1 Software Flash Drive
- 2 Threaded Aperture Caps
- 6 Threaded 1" Filter Retaining Rings
- 1 5/64" Ball Driver
- 1 Operating Manual

FEATURES

- Manual or Automated Control Capability
- Multi-Directional Controls
- Interchangeable Filter Retaining Wheels with six 1" (25mm) or twelve 1/2" (12.5mm) positions
- Selectable Aperture Openings At 12 O'clock and 9 O'clock
- 800 Millisecond Typical Access Time
- Accommodates up to 0.275" Filter Planar Width
- Lightweight with a Diversity of Mounting Capabilities

Motorized Filter Wheel 88398 / 88171

SPECIFICATIONS

ELECTRICAL

Parameter	Description
Power @ DC Input @ 1.2A	+5VDC
Operating Temperature	0°C to 60°C

MECHANICAL

Parameter	Description
Access Time Adjacent Locations	800ms
Accuracy/Repeatability	±0.25°

PHYSICAL

Parameter	Description
Power Jack	Male 2.1mm
USB Connector	Female Micro A
Mounting	¼-20, 8-32, M6-1, M4-.7, or SM1 Thread
Max Filter Diameter	1.0" (25.4 mm)
Max Planar Filter Width	0.275" (7mm)
Dimensions (L x W x H)	5.48" x 2.15" x 4.38" (139 x 55 x 111mm)

Figure 1: Mechanical Drawing, Front and Right Side

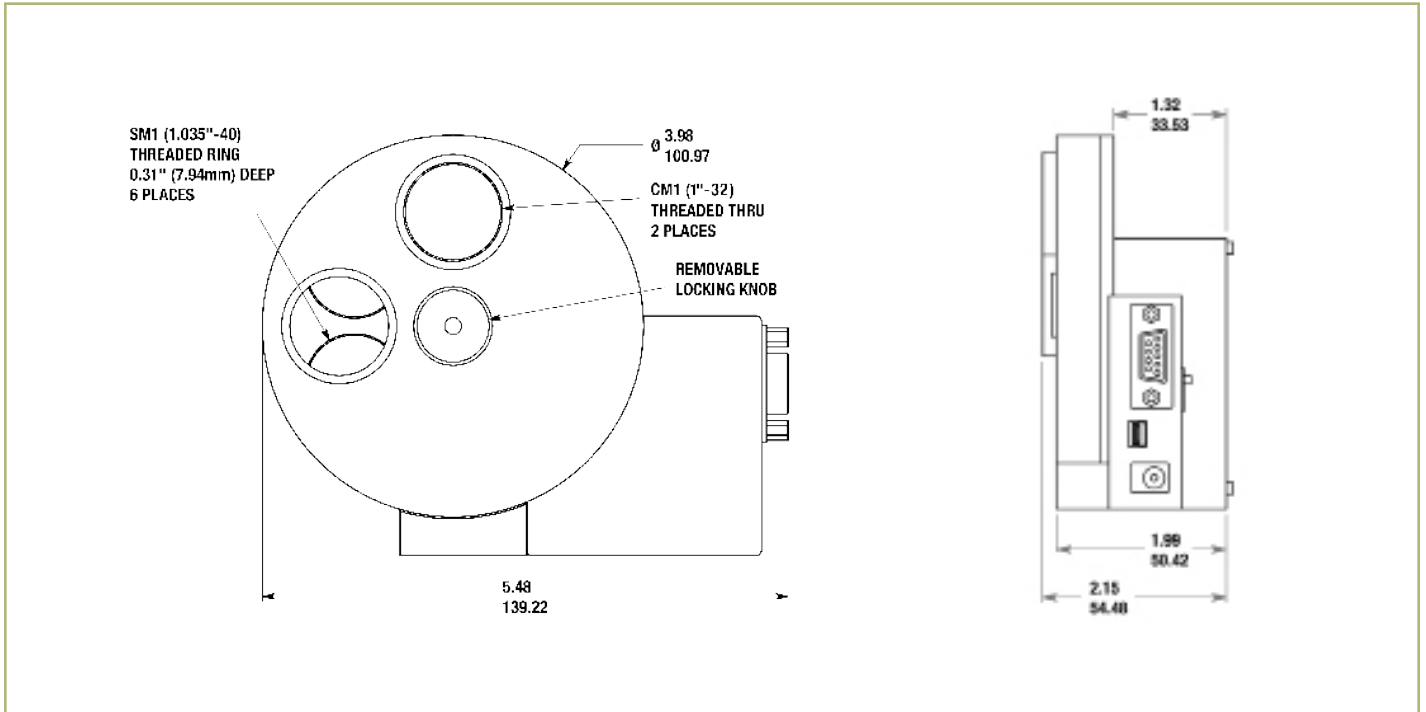
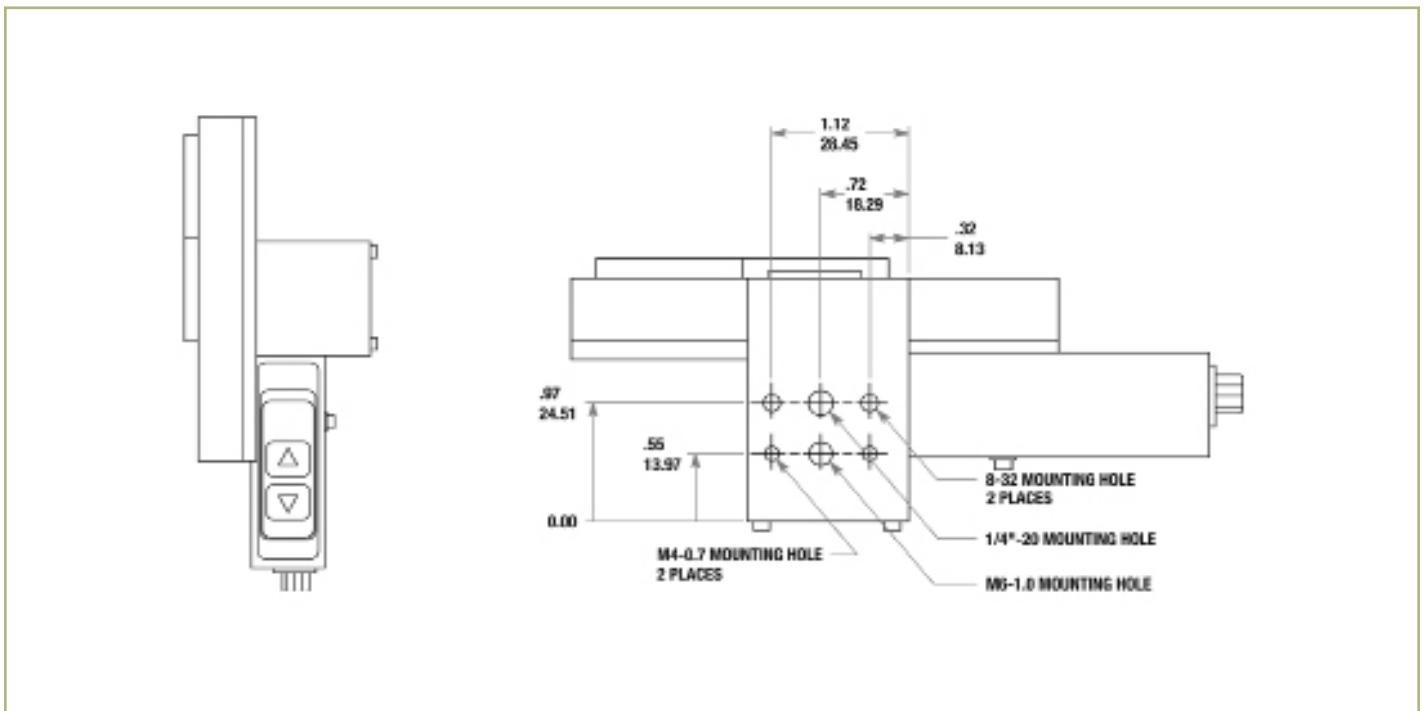
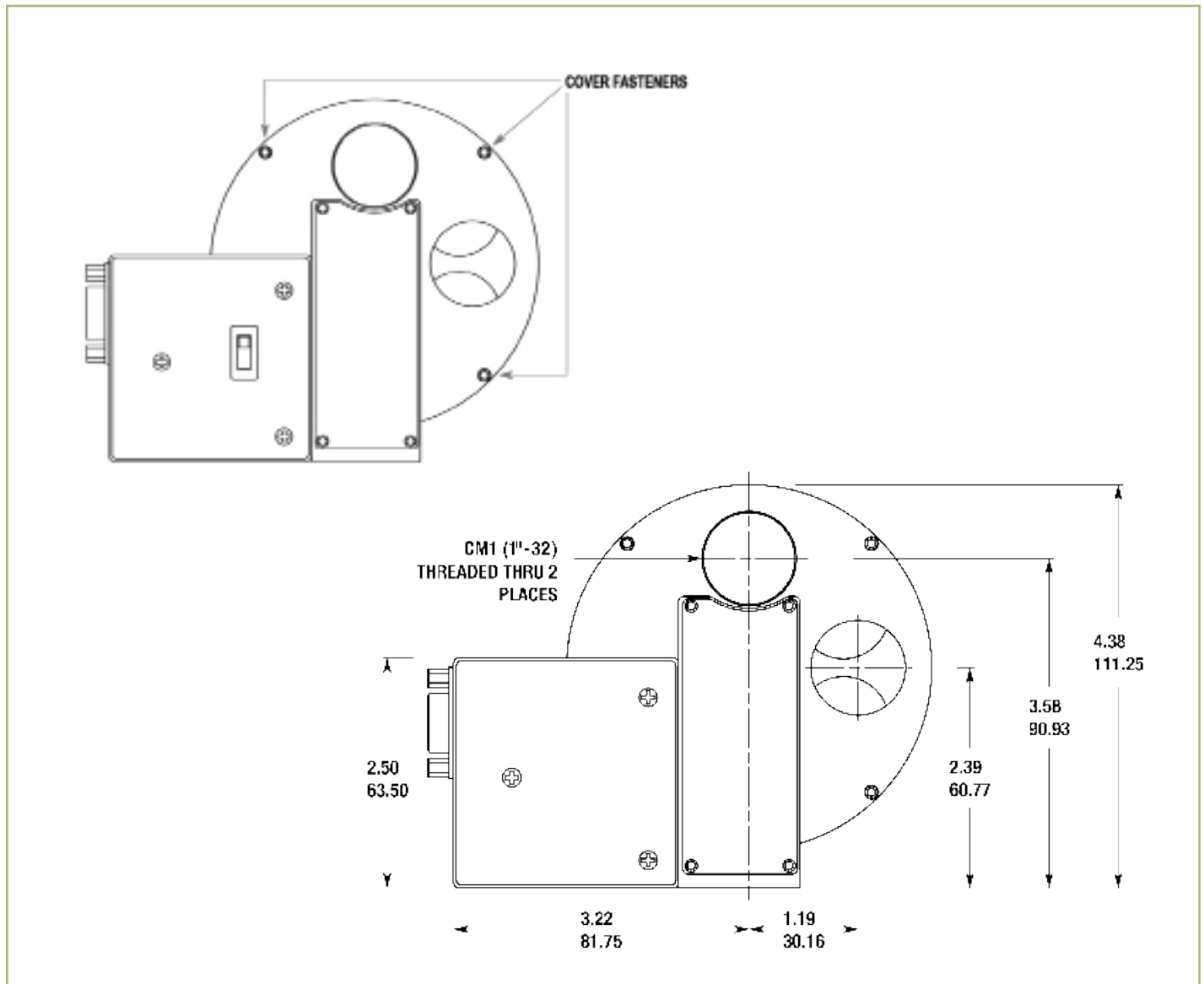

Figure 2: Mechanical Drawing, Top and Bottom



Motorized Filter Wheel 88398 / 88171

Figure 3: Mechanical Drawing, Back



OPERATION

The following sections describe the basic operation of the motorized filter wheel.

Mounting

The base of the unit contains six mounting holes: one 1/4"- 20, two #8-32, one metric M6-1.0, and two M4-0.7 threaded holes for mounting to optical tables and breadboards, see Figure 2. The filter wheel cover contains CM1 threads for attaching lens tubes or for mounting the 88171 directly to cameras, microscopes, and telescopes. Edmund Optics sells a host of adapters for the CM1 threads.

Power

The unit comes with an AC wall adapter to supply +5 VDC to the unit. Plug the adapter into a 120V US standard outlet then plug the 2.1 mm male plug from the AC adapter into the DC input jack on the unit. Upon power up, the unit will display the filter number located at the selected aperture. If the wheel is not located at a valid location, it will rotate to the closest valid position.

Aperture

The unit has two aperture locations at 12 O'clock and 9 O'clock. To toggle aperture selection, hold down both the up and down arrow buttons simultaneously for 2 seconds to trigger Aperture Selection Mode. The display will read either A1 or A2 pending the current aperture selection where A1 is the 12 O'clock position and A2 is the 9 O'clock position. You may now switch from one position to another by pressing either the up or down arrow buttons. The unit automatically rotates the selected filter to the correct aperture when the aperture selection is made. To exit Aperture Selection Mode repeat the process to enter it.

Manual Control

Depressing the UP/DOWN arrow buttons on the top of the unit (Figure 2) will increment and decrement the filter location. The arrows also indicate the direction of rotation for the wheel and the display will indicate the filter selection.

Installing Filters



WARNING: Prior to changing filters, ensure the unit is disconnected from the DC source.

The filters can be changed by first removing the filter wheel cover. Using the 5/64" ball driver provided, remove the three cover fasteners shown in Figure 3. Filters can now be inserted into the desired locations. Filters are secured to the wheel by inserting the provided the SM1RR-1CT retaining rings. Please note that the rear edge of the threaded filter holes contain a retaining lip to secure one edge of a 1" filter. 25mm filters may require a SM1RR-1CT on each side of the filter. Optionally, the entire filter wheel can be removed by unscrewing the locking knob shown in Figure 1 after removing the cover. When reattaching the filter wheel to the housing, align the guide pins from the housing to the guide holes on the wheel before attaching the locking knob. The unit will reorient after the first selection is made.

Capacity Switch

This switch located on the back of the unit toggles the amount of positions that the unit recognizes. It is used to switch from a six position filter retaining wheel to a twelve position filter retaining wheel. All other functions are unaffected by this switch.

Motorized Filter Wheel 88398 / 88171

SOFTWARE

This document details the manual and serial communication interface for the Motorized Filter Wheel. It also defines setup, data format and modes. Serial communication interface includes the RS232 or USB link. Manual interface includes the switch, two buttons and LED display.

Manual Interface

There are two push buttons and one slide switch on this device. The slide switch will be referred to as the Capacity Switch while the push buttons will be referred to as Up and Down.

Capacity Switch – This switch, located on the back of the unit, toggles the number of positions that the unit recognizes. It is used to switch from a six-position filter-retaining wheel to a twelve-position filter-retaining wheel. All other functions are unaffected by this switch.

Up/Down Push Buttons – These push buttons are used for three different functions:

Default Mode - Used to increment or decrement the filter wheel position.

Aperture Mode - During normal operation both buttons can be pressed simultaneously to enter 'Aperture Mode'. Once selected the user can press Up or Down to select aperture setting 'A1' or 'A2'.

Calibration Mode – This mode is primarily used during assembly. Holding both buttons down during power-up enters this mode. Once in this mode, the display shows 'CA', the motor is energized to one of its 48 discrete positions, and the encoder is instructed to store this location as its zero position. This all happens within one second. The motor is left energized so assembly personnel can align and press fit the filter wheel adaptor.

Serial Communications

Both hardware connections (USB and RS232) utilize COM ports. The USB link requires drivers to simulate a virtual COM port. They can be downloaded at the link below.

VCP Driver download page:

<http://www.ftdichip.com/Drivers/VCP.htm>

Follow the instructions found in appropriate document:

<http://www.ftdichip.com/Support/Documents/InstallGuides.htm>

Configure the COM port as follows:

Baud (bits per second) = 9600

Data bits per character = 8

Parity = None

Stop bits = 1

Flow Control = None

Data Format

If you are using the provided LabVIEW programs, you must run CheckComms.vi first to get the 'Duplicate VISA Resource Name'. Next, run GetSerialNumberofDevice.vi. Finally, to control the wheel, you can run USBComm.vi. First, choose the 'Com Port' from the drop down list that matches the 'Duplicate VISA Resource Name' from CheckComms.vi, and then start sending commands.

The "host" PC initiates each communication session with a single eight-bit command. The unit will respond to every valid command with a Status Reply. The commands can be sent as either hexadecimal or ASCII values. Please note that if you try to send hexadecimal commands as ASCII values, the filter wheel will not respond properly. For instance, sending a '64' command defined as a hexadecimal will cause the wheel to decrement one position. However, if you fail to define it as a hexadecimal value and just send '64' the wheel will either not respond at all or produce unexpected results. See the attached spreadsheet for a list of commands.

The filter wheel will respond to any code sent to it with a status update, which will be sent as 8-bit binary. The first four bits, referred to as the "upper nibble", denote the current position. These will be different between 12 O'clock and 9 O'clock aperture modes, and between 6-position and 12-position modes. Refer to the attached spreadsheet for these codes.

The last four bits, referred to as the "lower nibble", denote the 'mode' of the wheel at the time of the status update.

- Bit 4 – Aperture setting
 - 0 = A1 (12 O'clock)
 - 1 = A2 (9 O'clock)

- Bit 5 – Jam Error (read only)
 - 0 = No error
 - 1 = Jam

- Bit 6 – 6- or 12- Position Mode
 - 0 = 6 Position Wheel
 - 1 = 12 Position Wheel

- Bit 7 – Run or Sleep Mode (Note: Sleep Mode defaults wheel to 12 O'clock Aperture. You can wake it up in either mode.)
 - 0 = Run Mode
 - 1 = Sleep Mode

Motorized Filter Wheel 88398 / 88171

Codes

Command and Response Codes		
Command	Hexadecimal	ASCII
Increment Position	69	i
Decrement Position	64	d
Go to Position 1	31	1
Go to Position 2	32	2
Go to Position 3	33	3
Go to Position 4	34	4
Go to Position 5	35	5
Go to Position 6	36	6
Go to Position 7	37	7
Go to Position 8	38	8
Go to Position 9	39	9
Go to Position 10	3A	:
Go to Position 11	3B	;
Go to Position 12	3C	<
12 O'clock Aperture Mode	40	@
9 O'clock Aperture Mode	43	C
Sleep Mode	49	l
Status Request	73	s

Upper Nibble Response Codes (6 Position Wheel)		
Current Position	6 Position, 12 O'clock	6 Position, 9 O'clock
1	1000	1010
2	0100	0110
3	1100	1000
4	0010	0100
5	1010	1100
6	0110	0100

Upper Nibble Response Codes (12 Position Wheel)		
Current Position	12 Position, 12 O'clock	12 Position, 9 O'clock
1	1000	0101
2	0100	1101
3	1100	0011
4	0010	1000
5	1010	0100
6	0110	1100
7	1110	0010
8	0001	1010
9	1001	0110
10	0101	1110
11	1101	0001
12	0011	1001

REGULATORY

As required by the WEEE (Waste Electrical and Electronic Equipment Directive) of the European Community and the corresponding national laws, Edmund Optics offers all end users in the EC the possibility to return “end of life” units without incurring disposal charges.

- This offer is valid for Edmund Optics electrical and electronic equipment that is:
- Sold after August 13th 2005
- Sold to a company or institute within the EC
- Currently owned by a company or institute within the EC
- Still complete, not disassembled and not contaminated

As the WEEE directive applies to self contained operational electrical and electronic products, this end of life take back service does not refer to other Edmund Optics products, such as:

- Pure OEM products, that means assemblies to be built into a unit by the user (e. g., OEM laser driver cards)
- Components
- Mechanics and optics
- Left over parts of units disassembled by the user (PCB's, housing's etc.)

If you wish to return a unit for waste recovery, please contact Edmund Optics or your nearest dealer for further information.

Waste Treatment is Your Own Responsibility

If you do not return an “end of life” unit to Edmund Optics, you must hand it to a company specialized in waste recovery. Do not dispose of the unit in a litter bin or at a public waste disposal site.

Ecological Background

It is well known that WEEE pollutes the environment by releasing toxic products during decomposition. The aim of the European RoHS directive is to reduce the content of toxic substances in electronic products in the future.

The intent of the WEEE directive is to enforce the recycling of WEEE. A controlled recycling of end of life products will thereby avoid negative impacts on the environment.

Motorized Filter Wheel 88398 / 88171

EC DECLARATION OF CONFORMITY

We: Andover Corporation
4 Commercial Drive
Salem, NH 03079

declare that:

Equipment: Motorized Filter Wheel
Model Numbers: 88398, 88171

in accordance with the following Legislation:

- Conforms with the essential safety requirements of the Low Voltage Directive (2014/35/EU), and its amending Directives
- Conforms with the essential protection requirements of the Electromagnetic Compatibility Directive (2014/30/EU), and its amending Directives

has been designed and manufactured to the following specifications:

- EN 61010-1:2010
- EN 61326-1:2012

I hereby declare that the equipment named above has been assessed and found to comply with the relevant requirements of the applicable Legislation and I am the person authorized to compile the technical documentation.

Signed by: 
Name: David P. Litwinovich
Position: Senior Engineer
Date: 06/16/2016

LIMITED WARRANTY

Edmund warrants that all Products shall conform to the Product specifications and shall be free from defects in materials and workmanship for a period of one year from date of purchase. This Limited Warranty shall not apply in the event of any failure caused by accident, misuse, neglect, alteration or improper installation or repair by the Purchaser.

DISCLAIMER OF OTHER WARRANTIES – THE LIMITED WARRANTY SET FORTH ABOVE IS IN PLACE OF ALL OTHER WARRANTIES, EXPRESS OR IMPLIED, AND EDMUND EXPRESSLY DISCLAIMS ALL OTHER WARRANTIES, INCLUDING WARRANTIES OF MERCHANTABILITY AND FITNESS FOR A PARTICULAR PURPOSE. SPECIFICALLY, IT IS THE PURCHASER’S RESPONSIBILITY TO TEST AND DETERMINE THE SUITABILITY OF THE PRODUCTS FOR PURCHASER’S INTENDED USE WHICH SHALL BE THE SOLE RESPONSIBILITY OF THE PURCHASER.

LIMITATION OF REMEDIES AND DAMAGES - Edmund’s sole obligation and the Purchaser’s sole and exclusive remedy under the Limited Warranty set forth above shall be limited to (a) replacement of defective Products provided that written claim of the defect is sent to Edmund within the Limited Warranty Period, the original product is returned with transportation prepaid, and Edmund’s inspection establishes the existence of such defect; or (b) in the sole discretion of Edmund, return of the original purchase price received by Edmund from the Purchaser.

Edmund shall in no event be liable for any damages, including without limitation, lost profits, incidental or consequential damages by reason of or in connection with the purchase or use of the Products.

INDEMNIFICATION – The Purchaser agrees to indemnify and hold Edmund harmless from and against any claim, loss, cost or expense resulting from Purchaser’s use of the Products, whether such claim arises in contract, tort or otherwise.

GOVERNING LAW – All matters arising under this Limited Warranty and other terms and conditions of sale shall be governed by the laws of the State of New Jersey. The Purchaser consents to the exclusive jurisdiction of the courts of the State of New Jersey in all matters relating to the purchase, sale and use of the Products.

**Edmund Optics Inc.
101 East Gloucester Pike
Barrington, NJ 08007-1380 USA**

**Tel: 856-547-3488 Fax: 856-573-6295
www.edmundoptics.com**

Rev. F
Date: 16 June 2016