

NOTES:

- 1. RoHS: COMPLIANT

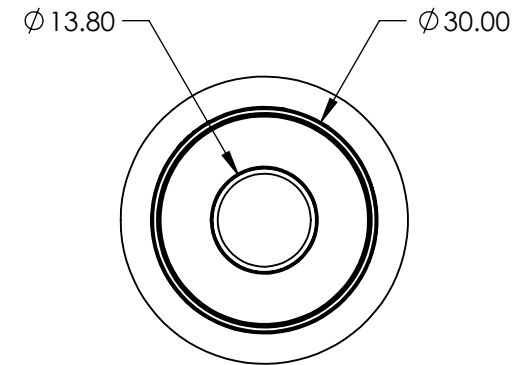
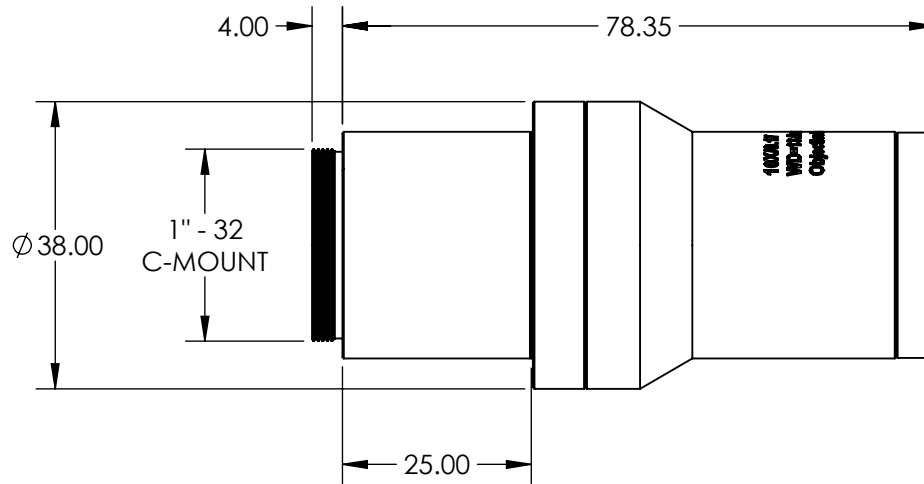

**FOR INFORMATION ONLY:  
DO NOT MANUFACTURE  
PARTS TO THIS DRAWING**

SPECIFICATIONS SUBJECT TO CHANGE WITHOUT NOTICE  
DIMENSIONS ARE FOR REFERENCE ONLY

	VALUE
FIELD OF VIEW, 1/2" SENSOR	0.64 x 0.48mm
FIELD OF VIEW, 2/3" SENSOR	0.88 x 0.66mm
MAGNIFICATION	10X
MAX SENSOR FORMAT	2/3"
NUMERICAL APERTURE	0.17
WORKING DISTANCE(mm)	13.5
STYLE	FINITE CONJUGATE



ALL DIMS IN

mm

**EO**® Edmund Optics®

TITLE

10X COMPACT ADJUSTABLE OBJECTIVE

DWG NO

88354

SHEET  
1 OF 1