

Closed-Loop Piezoelectric Stack Fitted with Strain Gauge, 150 V, 38.5 μm



Description

PK4FYC2

The PK4FYC2 is a discrete stack piezoelectric actuator with four attached metal foil strain gauges in a full-bridge Wheatstone circuit. The strain gauges are bonded to the durable epoxy resin coating that seals the actuator and its wire leads; a short length of Kapton[®] tape covers each of the strain gauges. The discrete stack piezoelectric actuator consists of multiple piezoelectric chips bonded together via epoxy and glass beads, and it provides a maximum displacement of 38.5 $\mu\text{m} \pm 15\%$. A red wire is attached to the electrode that should receive positive bias, and a black wire is attached to the electrode that should be grounded.

The wires attached to the actuator's electrodes have a larger diameter than the strain gauge wires (0.7 mm and 0.5 mm respectively). When connecting to the wires attached to the actuator's electrodes, the red wire should receive positive bias, and the black wire should be grounded. For the wires connected to the strain gauge circuit, the red and black wires are used to supply the input (bridge excitation) voltage, V_{ex} , to the strain gauge, and the blue and yellow wires are used to monitor the output voltage, V_o , of the strain gauge. Each individual strain gauge has a resistance of 350 Ω and a gauge factor of two. Additional information is included below.

Specifications

PK4FYC2 ^a	
Drive Voltage Range	0 - 150 V
Displacement (Free Stroke) at 150 V ^b	38.5 $\mu\text{m} \pm 15\%$
Hysteresis	<15% (See Graph on Next Page)
Load for Maximum Displacement ^c	400 N (90 lbs)
Recommended Preload	<400 N (90 lbs)
Blocking Force at 150 V	1000 N (225 lbs)
Resonant Frequency	34 kHz $\pm 15\%$ (No Load)
Anti-Resonant Frequency	42 kHz $\pm 15\%$ (No Load)
Impedance at Resonant Frequency	150 m Ω
Dissipation Factor ^d	<2.0%
Capacitance ^d	3.5 $\mu\text{F} \pm 15\%$
Operating Temperature	-25 to 65 $^{\circ}\text{C}$
Curie Temperature	230 $^{\circ}\text{C}$
Bridge Arm Resistance	350 $\Omega \pm 0.3\%$
Gauge Factor	2
Excitation Voltage (Recommended Max)	4.5 V _{rms}
Dimensions	Width 1: 7.3 mm Maximum Width 2: 6.5 mm Maximum Length: 36.0 mm ± 0.1 mm

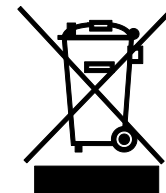

- All specifications are quoted at 25 $^{\circ}\text{C}$, unless otherwise stated.
- The "free stroke" displacement corresponds to no load.
- The displacement may vary slightly for different loads, and the maximum displacement occurs when used with the load for maximum displacement.
- Specified at 1 kHz, 1 V_{RMS}.

April 30, 2021

CTN009957-S01, Rev C

Mechanical Drawing

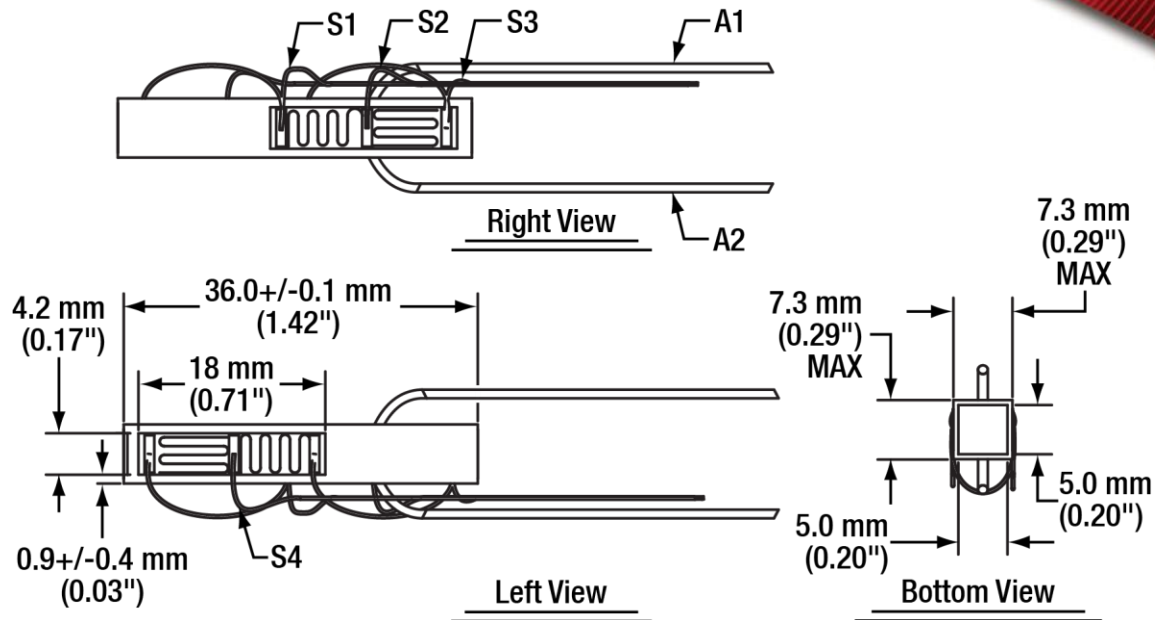

Label in Drawing	Wire Color	Wire Outer Diameter	Description
A1	Black	0.7 mm	Negative Actuator Wire, ~75 mm Long
A2	Red	0.7 mm	Positive Actuator Wire, ~75 mm Long
S1	Black	0.5 mm	- V_{ex} Strain Gauge Wire, 260 mm Long
S2	Yellow	0.5 mm	- V_0 Strain Gauge Wire, 260 mm Long
S3	Red	0.5 mm	+ V_{ex} Strain Gauge Wire, 260 mm Long
S4	Blue	0.5 mm	+ V_0 Strain Gauge Wire, 260 mm Long

Typical Performance Plots

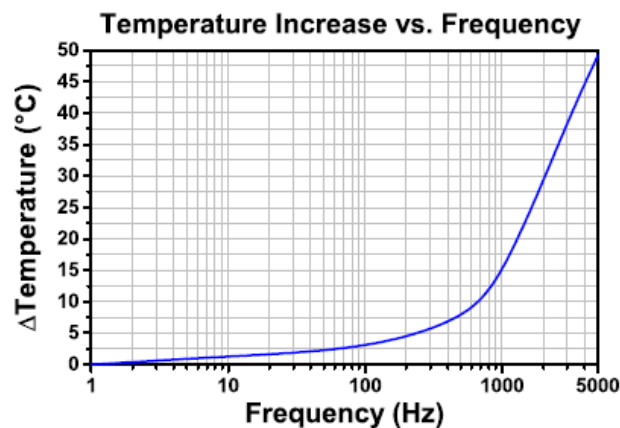

The temperature increase of the chip was measured after applying a sine-wave drive voltage, with maximum and peak-to-peak amplitudes of 150 V, at the specified frequency for minutes.

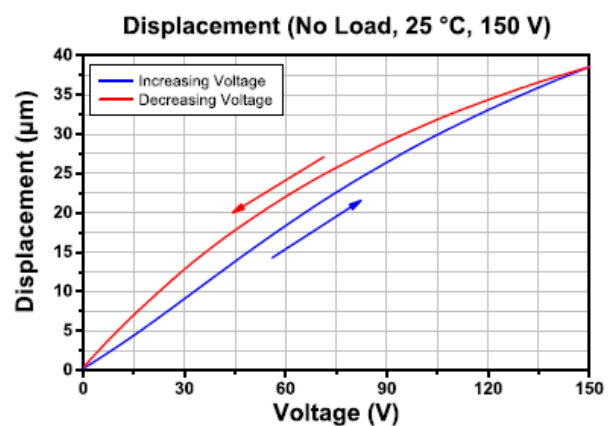

Operation

The four foil strain gauges are connected in a Wheatstone bridge circuit as illustrated in the following diagram.

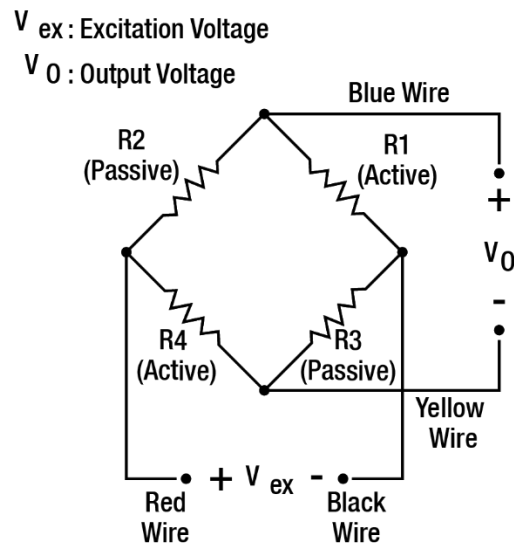

Electrical Connections to the Strain Sensor: The maximum recommended value of the excitation voltage, V_{EX} , is $4.5 V_{rms}$. The output voltage of the full bridge circuit, V_0 , can be used as a feedback signal by a controller to provide linear operation of the piezoelectric actuator. As the output signal of the circuit is small in magnitude, it will typically be necessary to amplify it before sending it to a strain gauge reader like Thorlabs' **KSG101**. We recommend using a pre-amplification circuit like Thorlabs' **AMP002** to amplify the V_0 signal. Please consult the manual of the **AMP002** for information on properly connecting it to the PK4FYC2. The required value of the ID resistor (R_6) described in the **AMP002** manual is 1% 0.25 W 3 k Ω .

Electrical Connections to the Piezoelectric Actuator: The electrode attached to the larger diameter (0.7 mm) red wire should be positively biased, and the electrode attached to the larger diameter (0.7 mm) black wire should be grounded. The recommended maximum drive voltage is 150 V, and the absolute maximum voltage is 150 V. Exceeding 150 V will decrease the device's lifespan and may cause mechanical failure. Reverse biasing the device may cause mechanical failure. After driving, the piezo is fully charged.

Caution: Directly connecting the red and black wires has the risk of electricity discharging, spark, and even failure. We recommend using a resistor (>1 k Ω) between the red and black wires to release the charge.

Attaching Devices to the Piezo: Any epoxy which cures at a temperature lower than 80 °C is safe to use. We recommend Thorlabs Item #s 353NDPK or TS10. Loctite® Hysol® 9340 is also usable. Loads should only be attached to the uncoated faces since the polymer-coated faces do not translate. Attaching a load to the coated faces may lead to mechanical failure.

Storage Instructions: Do not store the device at temperature above 110 °C. Do not store the device in humid environment. The relative humidity (RH) should be less than 40%. Do not immerse the device in organic solvents. Do not use the device around combustible gases or liquids.