

7 C DMF ÷ < H Í ' & \$\$\$ + ' V m H k C F @ 5 6 G ' B 7 "

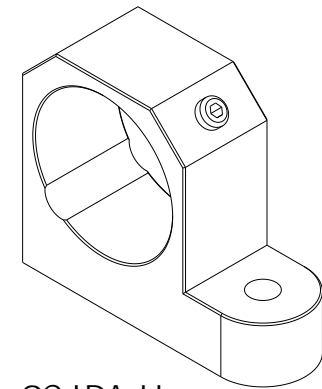

9C ! DA H

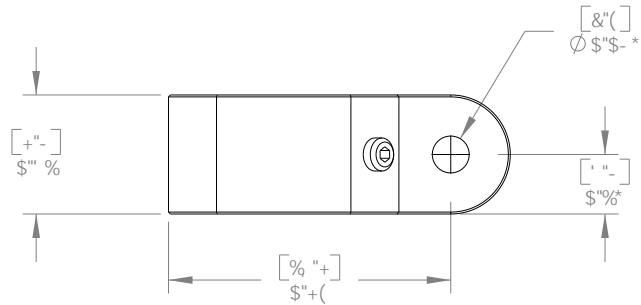
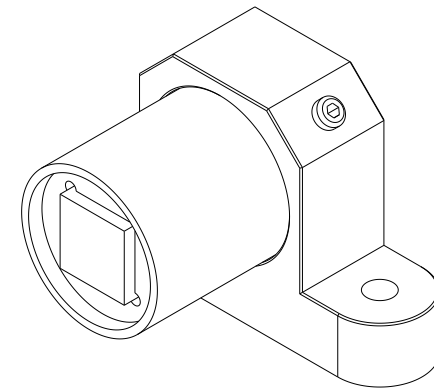
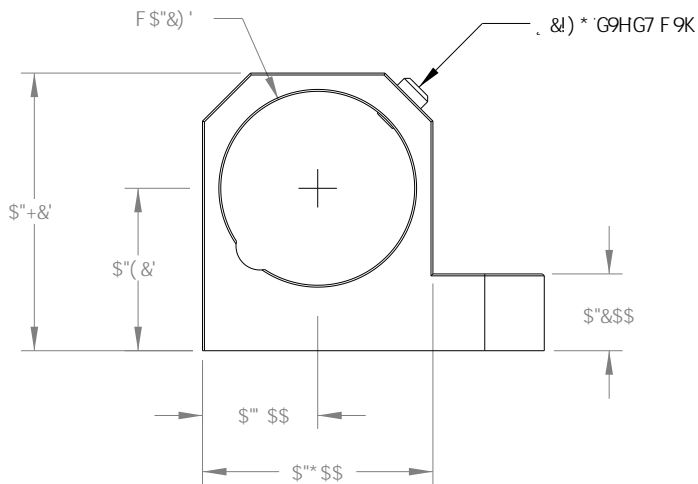

9C ! ; H k ) A

**HC @ F 5 B 7 9 G**

1 B @ 9 G C H : 9 F K @ 9 G D 9 7 ÷ 9 8 .  
 8 A 9 B G C B G 5 F 9 B ' B 7 < 9 G  
 @ B 9 5 F H C @ F 5 B 7 9 G '  
 ... H C D @ 5 7 9 8 9 7 A 5 @ ± \$ \$ % \$  
 ... H : F 9 9 D @ 5 7 9 8 9 7 A 5 @ ± \$ \$ % \$  
 5 B : 1 @ 5 F . ± ' \$ π ...  
 G I F : 5 7 9 : B G < . ' & A 7 F C B 7 < 9 G  
 D 5 F 5 @ @ C A . \$ \$ \$ &  
 : @ 5 B 9 G \$ \$ \$ &  
 G F 5 ÷ < H B 9 G \$ \$ \$ &  
 7 C B 7 9 B H F 7 H M \$ \$ \$ &  
 D 9 F D 9 B 8 7 1 @ 5 F H M \$ \$ \$ &  
 H : F 9 5 8 . 7 @ 5 G G & : H

	B 5 A 9	8 5 H 9
8 F 5 K B	9 7	( # - # \$ +
9 B : ' 5 D D F "	9 7	( # - # \$ +
A : : ' 5 D D F "	9 7	( # - # \$ +
<b>D F C D F - 9 6 F M 5 B 8 7 C B : 8 9 B H 5 @</b>		
H : 9 B : C F A 5 H C B 7 C B H 5 B 9 8 B H k G		
8 F 5 K B : ' 6 H : 9 G C @ D F C D 9 F H M C :		
H : C F @ 5 6 G ' B 7 " ' 5 B M F 9 D F C 8 1 7 H C B		
B D 5 F H C F 5 G 5 K < C @ K H C I H		
H : 9 K F # 9 8 D 9 F A 6 G C B C :		
H : C F @ 5 6 G ' B 7 " 6 D F C < 6 + 9 8 "		

H k C F @ 5 6 G ' B 7 " DC ' 6 C L ' \* \*  
 B 9 K H C B ' B >

H # @ .	
9 C ' A C 8 I @ 5 H C F ' G K ÷ 9 @ A C I B H	
A 5 H 9 F 5 @	G # 9 F 9 J "
6 @ 5 7 ? ' 5 B C 8 # 9 8 ' 5 @ A B I A	5 5
G 7 5 @ . & %	G < 9 9 H % C : %
8 K ; " " B C "	D 5 F H B C "
% * ) ) \$ ! 9 \$ %	9 C ! D A H # ' 9 C ! ; H k ) A