

Piezoelectric Chip with Wires, 150 V, 2.2 μm Travel

PA4GEW

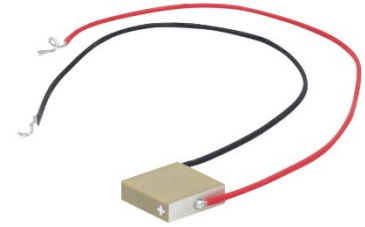

Description

The PA4GEW piezoelectric chip consists of stacked piezoelectric ceramic layers (which are mechanically in series) that are sandwiched between interdigitated electrodes (which are electrically in parallel). It offers a maximum displacement of $2.2 \mu\text{m} \pm 15\%$. A red wire is located next to the electrode that should receive positive bias; the other electrode should be grounded.

Specifications

PA4GEW ^a	
Drive Voltage Range	0 - 150 V
Displacement (Free Stroke) at 150 V	$2.2 \mu\text{m} \pm 15\%$
Hysteresis	<15% (See Graph on Next Page)
Load (Recommended)	785 N (177 lbs)
Blocking Force at 150 V	1960 N (441 lbs)
Resonant Frequency	225 kHz (No Load)
Impedance at Resonant Frequency	120 m Ω
Anti-Resonant Frequency	285 kHz
Dissipation Factor	<2.0%
Capacitance	390 nF $\pm 15\%$
Operating Temperature	-25 to 130 °C
Curie Temperature	230 °C
External Electrodes	Screen-Printed Silver
Dimensions	Width 1: 7.0 mm ± 0.1 mm Width 2: 7.0 mm ± 0.1 mm Length: 2.0 mm $\pm 5 \mu\text{m}$

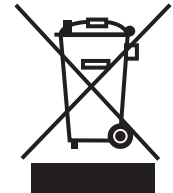

a. All specifications are quoted at 25 °C, unless otherwise stated.

Drawing

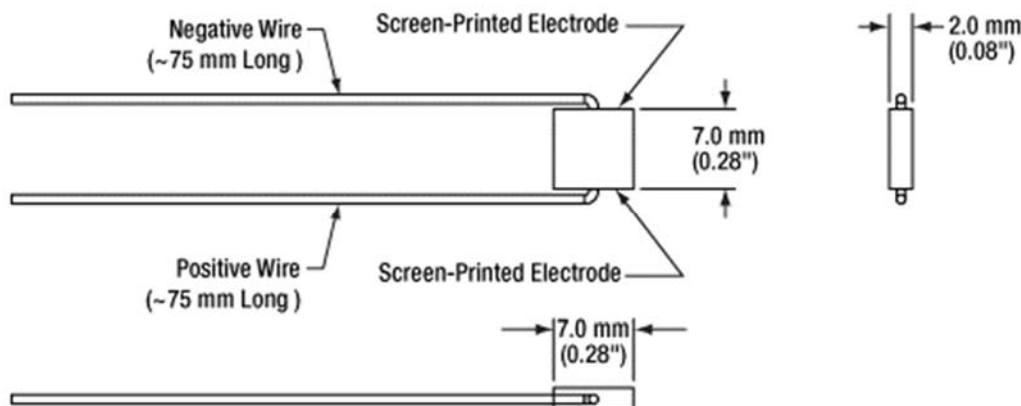

July 10, 2020

CTN002590-S01, Rev B

Typical Performance Plots

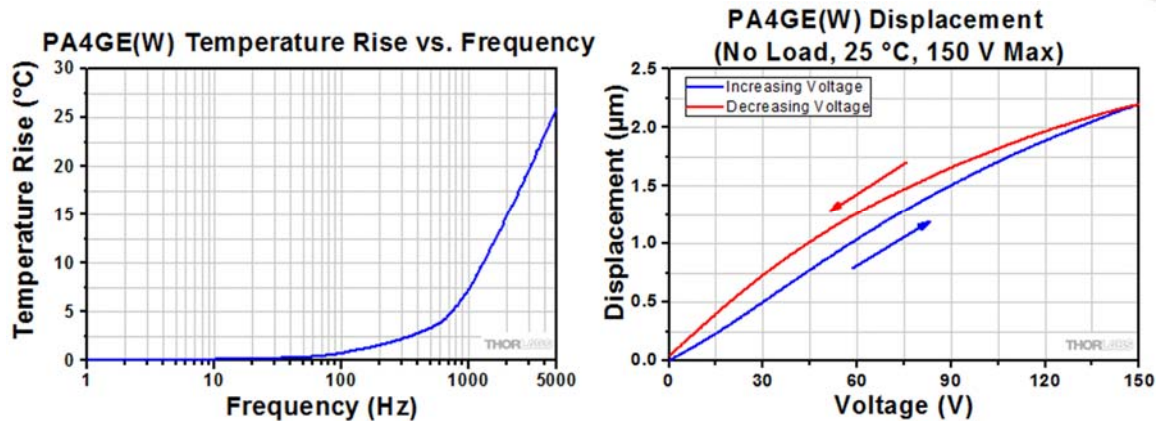

These temperature rises were measured after applying a sine-wave drive voltage ranging from 0 to 150 V at the specified frequency for 10 minutes at room temperature.

Operation

Electrical Considerations

- The electrode attached to the red wire should be positively biased, and the electrode attached to the black wire should be grounded. The maximum drive voltage is 150 V. Exceeding 150 V will decrease the device's lifespan and may cause mechanical failure. Reverse biasing may cause mechanical failure.
- When soldering wires to the electrodes, use a temperature no greater than 370 °C (700 °F) for a maximum of 2 seconds per spot. Solder to the middle of the electrode, keeping the spot as small as possible.
- Caution: After driving, the piezo is fully charged. Directly connecting the red and black wires has the risk of electricity discharging, spark, and even failure. We recommend using a resistor (>1 kΩ) between the wires to release the charge.

Attaching Devices to the Piezo

- Any epoxy which cures at a temperature lower than 80 °C is safe to use. We recommend Thorlabs Item Numbers 353NDPK or TS10. Loctite Hysol 9340 is also usable.
- Loads should only be attached to the central area of the largest face since the edges do not translate. Attaching a load to the smaller faces may lead to mechanical failure.

Storage Instructions

- Do not store the device at temperatures above 80 °C.
- Do not store the device in humid environments. The relative humidity (RH) should be less than 40%.
- Do not immerse the device in organic solvents.
- Do not use the device around combustible gases or liquids.