

F9J "	89G7 F-DHC B.	B5A 9#85H9.

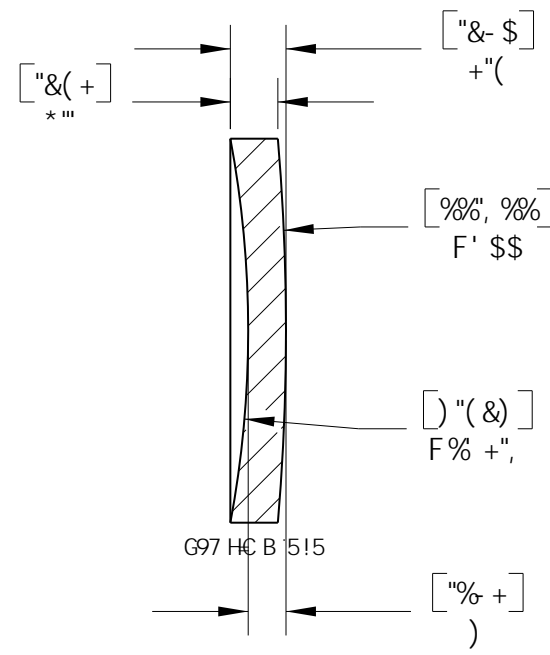
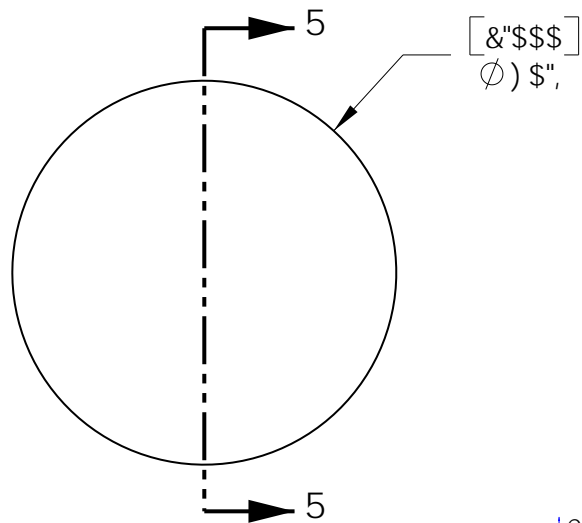

I B 7 C 5 H 9 8

*C 7 5 @ @ B ; H k . !) \$ \$ " \$ a
6 5 7 ? : C 7 5 @ ! (- + " & a a
B 8 9 L . %) %) 4 * ' ' ' b a
8 9 G = B ' K 5 J 9 @ B ; H k . ' * ' ' b a
G 7 F 5 H 7 < # 8 = . (\$ # & \$
8 - 5 A 9 H F ' H C @ F 5 B 7 9 . Z \$ " \$ \$ a a # \$ " % \$ a a
7 @ 9 5 F ' 5 D 9 F H F 9 . O - \$ i
7 9 B H F 5 H C B . ' ' 5 F 7 ' A B
7 9 B H 9 F ' H k - 7 ? B 9 G G ' H C @ F 5 B 7 9 . - \$ " % a a
7 < 5 A : 9 F ' \$ " & \$ a a ' 5 H () \$ 5 @ G < 5 F D ' 9 8 ; 9 G
9 8 ; 9 H k - 7 ? B 9 G G 5 G G I A B ; ' G < 5 F D ' 9 8 ; 9
5 B 8 ; = 9 B ' 6 9 . C F 9 7 < 5 A : 9 F

BCH9.
: CF 'B: CFA 5HC B 'CB@M
BCH: CF'A 5BI : 57H F-B;

5@I B+G; = 9B 'B'A @A 9HFG

HC@F5B79G	B5A 9	85H9
I B @ 9 G G C H : 9 F K @ 9 G D 9 7 = 9 8 .	8 F 5 K B	5 D) # 8) # & \$ \$ *
8 - A 9 B G C B G 5 F 9 - B ' B 7 < 9 G	9 B : ' 5 D D F "	H C) # 8) # & \$ \$ *
@ B 9 5 F ' H C @ F 5 B 7 9 G :	A : : ' 5 D D F "	H C) # 8) # & \$ \$ *
... H k C D @ 5 7 9 8 9 7 - A 5 @ ± \$ \$ % \$	DFC DF - 9 6 F M 5 B 8 7 C B : - 9 8 H 5 @	
... H k F 9 9 D @ 5 7 9 8 9 7 - A 5 @ ± \$ \$ % \$	H k 9 B : C F A 5 H C B 7 C B H 5 B 9 8 - B H k G	
5 B : I @ F . ' ± ' \$ π "	8 F 5 K B : ' G H : 9 G C @ 9 D F C D 9 F H M C :	
Q I F : 5 7 9 : B G < . " & A = 7 F C - B 7 < 9 G	H k C F @ 5 6 G 2 - B 7 " 5 B M F 9 D F C 8 I 7 H C B	
D 5 F 5 @ @ @ C A . \$ \$ \$ &	B D 5 F H C F 5 G 5 K < C @ K H k C I H	
: @ 5 H 9 G G \$ \$ \$ &	H k 9 K F # 9 8 - D 9 F A G G C B C :	
G F 5 = < H 9 G G \$ \$ \$ &	H k C F @ 5 6 G 2 - B 7 " G D F C < - 6 + 9 8 "	
7 C B 7 9 B H F = 7 H M \$ \$ \$ &		
D 9 F D 9 B 8 - 7 I @ 5 F H M \$ \$ \$ &		
H k F 9 5 8 . 7 @ 5 G G & : # I		

H k C F @ 5 6 G ' B 7 " DC ' 6 C L ' " * *	
B 9 K H C B ' B >	
H # @ .	
«) \$ " , a a ' 6 ? + ' B 9 . 5 H 9 ' A 9 B - G 7 I G @ 9 B G	
A 5 H 9 F 5 @	G # 9 F 9 J "
6 ? + Z ; f U X Y ' 5	5 5
G 7 5 @ 9 . % %	G < 9 9 H % C : %
8 K ; " " B C "	D 5 F H ' B C "
' (, - ! 9 \$ %	@ % \$, -