

F9J "	89G7 F-DHC B.	B5A 9#85H9.

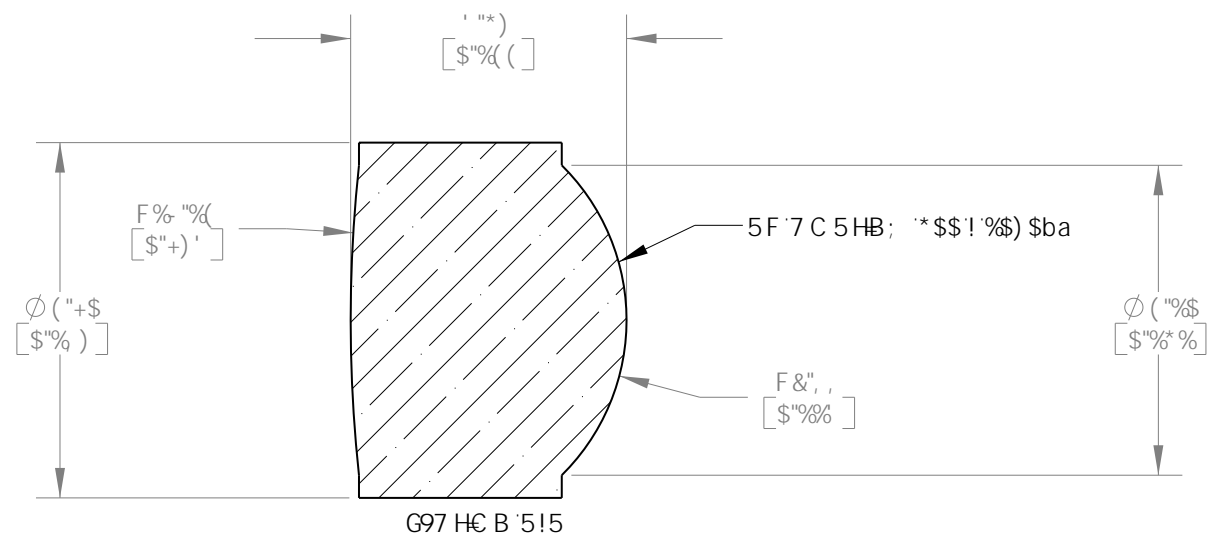
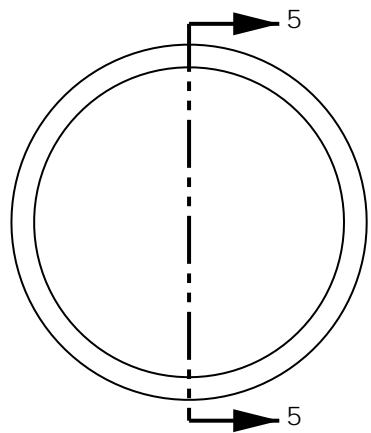
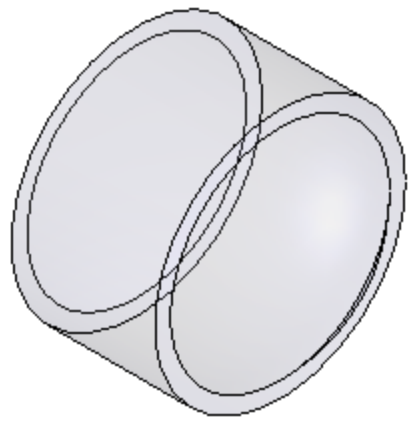

GD97 ÷ 7 5HC BG

89G≠ B'K 5J 9@B; H:.-, \$ba
 BI A 9F 7 5@5D9FH F9.'\$(&
 7 @95F 5D9FH F9." "+\$a a
 9.: 97HJ 9:C 75@@B; H:.("\$a a
 A 5; B ÷ 7 5HC B. B: B +P
 FA GK : 9. 0'8 ÷: " @A #
 K CF? B; 8 G 5B7 9. &" , 'a a
 : CF B: CFA 5HC B'CB @M
 BCH BHP B898 : CFA 5BI : 57H F B;

HC@F5B79G	B5A 9	85H9
1 B@9GGCH:9FK @9 GD97 ÷98.	8F5K B	8D
8-A 9BGC BG5F9-B'A @A 9F9G	9B: '5DDF"	?A G
@B95F HC@F5B79G	A:: '5DDF"	HC
...CB9D@579897-A 5@±\$&	DFC DF-56FM5B8 7CB: @9BH5@	
...HK C D@579897-A 5@±\$\$(H:9 B: CFA 5HC B 7 C B H 5 B 98 B H: G	
5B: 1 @F. ±' \$π"	8F5K B: "GH: 9GC @9 DFC D9F HMC:	
	H: C F @5 6Gz-B7 " 5BMF9DFC 8I 7 HC B	
	B D5FHC F 5G5 K <C @K H: C 1 H	
	H: 9K F H9B D9FA @GC B C:	
	H: C F @5 6Gz-B7 " 4DFC < 6+98"	

Hk C F @5 6Gz-B 7 "		DC '6CL" **
		B9K HC B B>
H# @.		
5GD< 9F 7 ' @9BGZ1 (') \$'a a 'B5 1 '\$'(%		
A 5H9F 5@	G#9	F9J "
7 C FB B; ; @5GG7 \$))\$	5	5
G7 5 @. %\$.%	G< 99HC : %	
8K ; "BC "	D5FH BC "	
% &) !9\$%	') \$') \$!6	