

F9J "	89G7 F-DHC B.	B5A 9#85H9.

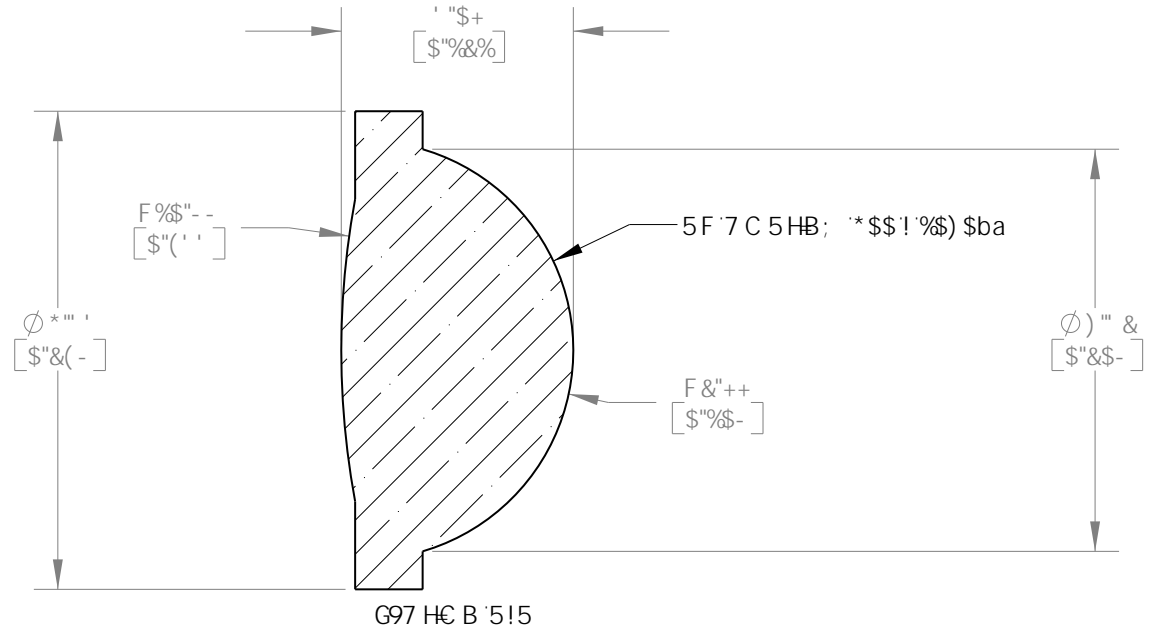
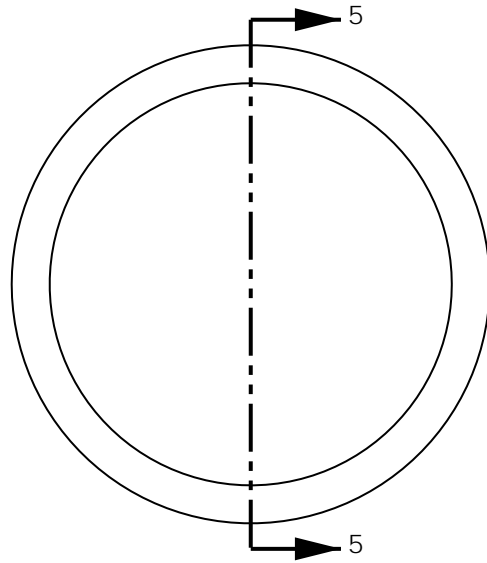
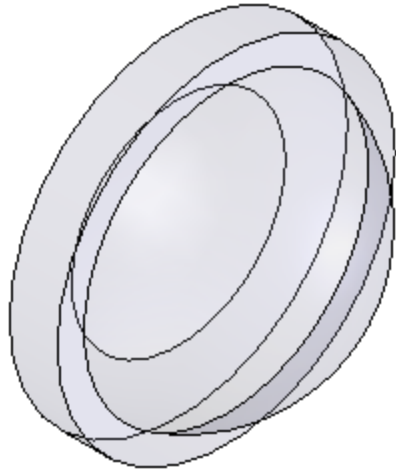

GD97 ÷ 7 5HC BG

89G ÷ B K 5J 9@B; H: '*,) ba
 BI A 9F 7 5@5D9FH F9: '\$"* &
 7 @95F 5D9FH F9.) "\$\$ a a
 9: : 97 HJ 9: C 7 5@9B; H: (" '\$' a a
 A 5; B ÷ 7 5HC B: B: B ÷ 9
 FA GK : 9: O'8 ÷: " @A #
 K C F ? B; 8 G 5B 7 9: %) *' a a

: CF B: CFA 5HC B C B @M
 BCH-BH898: CFA 5BI: 57H F B;

HC@F5B79G	B5A 9	85H9
1 B@9GGCH: 9FK @9 GD97 ÷ 98.	8F5K B	8D
8-A 9BGC BG5F9-B'A @A 9@FG	9B: 5DDF"	?A G
@B95F HC@F5B79G	A: : 5DDF"	HC
...CB9D@79897-A 5@±\$&	DFC DF-96FM5B87CB: @98H5@	
...HK C D@79897-A 5@±\$\$(H: 9 B: CFA 5HC B 7 C B H5 B 98 B H: G	
5B: 1 @F: ±' \$π"	8F5K B: :GH: 9GC @DFC D9F HMC:	
	H: C F @56Gz-B7 " 5BMF9DFC 8I 7 HC B	
	B D5FHC F 5G5 K < C @K H: C I H	
	H: 9K F #H8 D9FA @GC B C:	
	H: C F @56Gz-B7 " 4DFC < 6+98"	

Hk C F @56Gz-B7 " DC 6CL" **	
B9K HC B B >	
H#@.	
5GD<9F 7 '@9BGZ1('\$' a a 'B5'1 '\$"* &	
A 5H9F 5@	G#9 F9J "
7 C F B-B; ; @GG7 \$))\$	5 5
G7 5@. %\$.%	G< 99H% C: %
8K; "BC"	D5FH BC "
, , - +!9\$%	') '\$ (\$16