THORLABS

PDA20H(-EC) PbSe Preamplified Detector

User Guide



















Table of Contents

Chapter 1	Warning Symbol Definitions	2
Chapter 2	Description.....	3
	2.1. Introduction.....	3
	2.2. Maintenance and Care.....	3
Chapter 3	Setup and Operation	4
	3.1. Setup	4
	3.2. Operation	4
Chapter 4	Fiber Adapters & Other Accessories	5
Chapter 5	Specifications	6
	5.1. Electrical Specifications.....	6
	5.2. General Specifications	6
	5.3. Photosensitivity	7
Chapter 6	Drawing	8
Chapter 7	Regulatory.....	9
Chapter 8	Thorlabs Worldwide Contacts.....	10

Chapter 1 Warning Symbol Definitions

Below is a list of warning symbols you may encounter in this manual or on your device.

Symbol	Description
	Direct Current
	Alternating Current
	Both Direct and Alternating Current
	Earth Ground Terminal
	Protective Conductor Terminal
	Frame or Chassis Terminal
	Equipotentiality
	On (Supply)
	Off (Supply)
	In Position of a Bi-Stable Push Control
	Out Position of a Bi-Stable Push Control
	Caution: Risk of Electric Shock
	Caution: Hot Surface
	Caution: Risk of Danger
	Warning: Laser Radiation
	Caution: Spinning Blades May Cause Harm

Chapter 2 Description

2.1. Introduction

The PDA20H is a voltage-amplified PbSe detector designed for detection of light signals from 1.5 μm to 4.8 μm . A buffered output drives a 50 Ω input impedance up to ± 5 V. The PDA20H housing includes a removable SM1T1 threaded coupler that is compatible with Thorlabs SM05- (0.535"-40) and SM1-threaded (1.035"-40) accessories. This allows convenient mounting of external optics, light filters, and apertures, as well as providing an easy connection to Thorlabs' cage systems.

The PDA20H has two 8-32 tapped mounting holes with a 0.25" mounting depth and includes a 120 VAC AC/DC power supply. The PDA20H-EC has two M4 tapped mounting holes and includes a 230 VAC AC/DC power supply.

2.2. Maintenance and Care

There are no serviceable parts in the PDA20H optical head or power supply. The housing may be cleaned by wiping with a soft damp cloth. The window of the detector should only be cleaned using optical grade wipes. If you suspect a problem with your PDA20H, please call Thorlabs and an engineer will be happy to assist you.

Chapter 3 Setup and Operation

3.1. Setup

To properly unpack and assemble your PDA20H, follow the steps below.

Unpack the optical head and install a Thorlabs Ø1/2" TR post into one of the 8-32 (M4 in –EC version) tapped holes. Mount into a PH post holder.

Connect the 3-pin power supply plug into the mating receptacle on the PDA20H.

Plug the power supply into a 50 – 60 Hz, 100 – 120 VAC outlet (220 – 240 VAC for –EC version).

Attach a 50 Ω coaxial cable (for example, Thorlabs' 2249-C-24) to the BNC output port.

Note: When running cable lengths longer than 12", we recommend terminating the opposite end of the coax with a 50 Ω resistor (such as Thorlabs' item number T4119) for maximum performance.

3.2. Operation

To power on the PDA20H, turn the POWER switch to the "I" position. ("O" indicates the unit is off).

The light-to-voltage conversion can be estimated for a 22 °C ambient temperature by consulting the photosensitivity graph on Page 7. The data shown is for a 50 Ω load.

The maximum output of the PDA20H is ±10 V for high impedance loads (±5 V for 50 Ω loads). The output signal should be below the maximum output voltage to avoid saturation. If necessary, use external neutral density filters to reduce the input light level.

Chapter 4 Fiber Adapters & Other Accessories

Thorlabs sells a number of accessories that are compatible with the SM05 (0.535"-40) and SM1 (1.035"-40) threads on the housing, including FC, SMA, and ST fiber adapters, stackable lens tubes for mounting optics, and cage assemblies that allow the detector to be incorporated into elaborate 3D optical assemblies.



CAUTION



The PDA20H was designed to allow maximum accessibility to the photodetector by having the front surface of the diode flush with the outside of the PDA housing. When using fiber adapters, make sure that the fiber ferrule does not crash into the detector. Failure to do so may cause damage to the diode and/or the fiber. An easy way to accomplish this is to install a SM1RR retaining ring (included with the PDA20H) inside the SM1T1 threaded coupler before installing the fiber adapter.

Chapter 5 Specifications

5.1. Electrical Specifications

Electrical Specifications	
Detector	PbSe
Active Area	2 x 2 mm
Wavelength Range	1.5 μm to 4.8 μm
Peak Wavelength (λ_p)	4.0 μm
Bandwidth (-3 dB)	0.2 Hz to 10 kHz
Rise Time (0 - 63%)	35 μs
Voltage Gain ^a	50x / 100x
Output Voltage ^a	$\pm 5 \text{ V} / \pm 10 \text{ V}$
NEP ^b	$1.5 \times 10^{-10} \text{ W}/\sqrt{\text{Hz}}$
Detectivity, D* (at λ_p)	$1.3 \times 10^9 \text{ cm} \times \sqrt{\text{Hz}}/\text{W}$
Peak Sensitivity	$3.0 \times 10^3 \text{ V/W}$ (Typ.) $1.5 \times 10^3 \text{ V/W}$ (Min.)

5.2. General Specifications

General Specifications	
On / Off Switch	Slide
Output	BNC
Package Dimensions	2.76" x 1.70" x 0.83" (70.1 mm x 43.2 mm x 21.1 mm)
Weight	0.15 lbs (Detector Only) 2.5 lbs (Detector and Power Supply)
Accessories	SM1T1 Coupler SM1RR Retaining Ring
Storage Temperature	-25 to 70 °C
Operating Temperature	10 to 40 °C
AC Power Supply	AC – DC Converter
Input Power	100 – 120 VAC (220 – 240 VAC for –EC Version) 50 – 60 Hz, 5 W

^aValue at 50 Ω load / Value at Hi-Z load.

^bNEP measurement parameters: 300 K blackbody source, 600 Hz chopping frequency, 635 Hz bandpass filter with 70 Hz noise bandwidth and 22 °C ambient temperature.

5.3. Photosensitivity

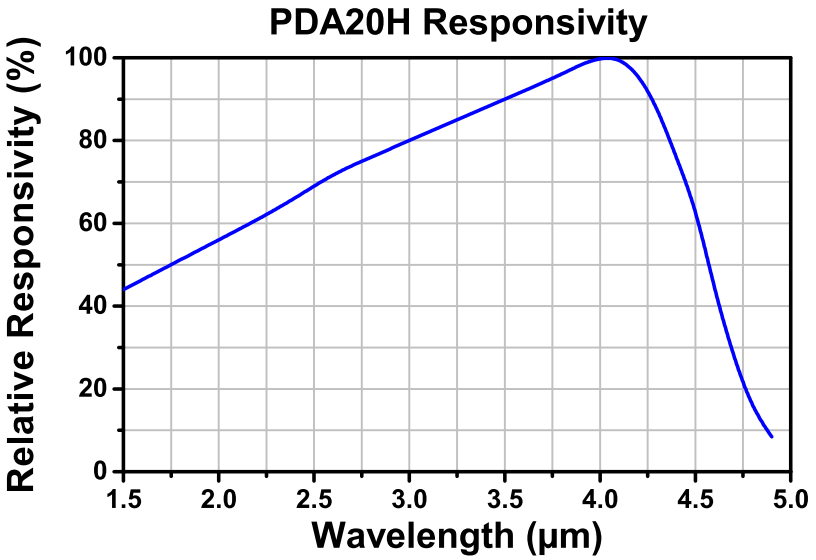

Data shown in graph above is for a 50 Ω load.

Chapter 6 Drawing

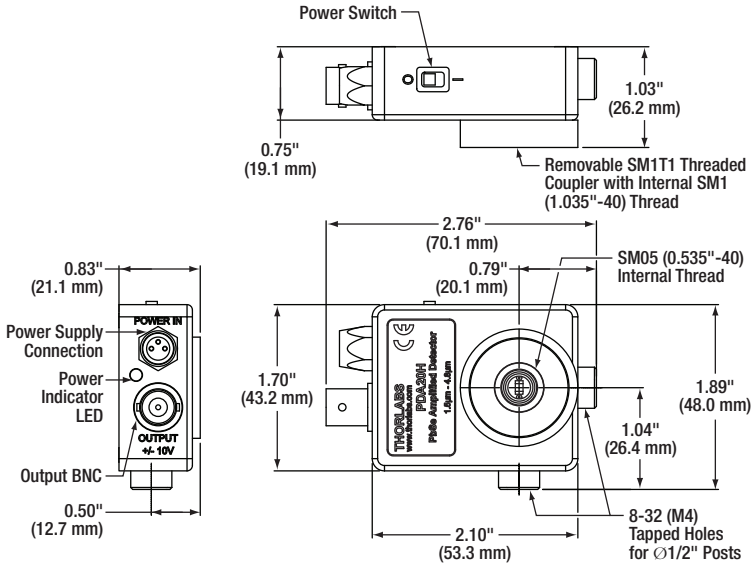

Chapter 7 Regulatory

As required by the WEEE (Waste Electrical and Electronic Equipment Directive) of the European Community and the corresponding national laws, Thorlabs offers all end users in the EC the possibility to return “end of life” units without incurring disposal charges.

This offer is valid for Thorlabs electrical and electronic equipment:

Sold after August 13, 2005

Marked correspondingly with the crossed out “wheelie bin” logo (see right)

Sold to a company or institute within the EC

Currently owned by a company or institute within the EC

Still complete, not disassembled and not contaminated

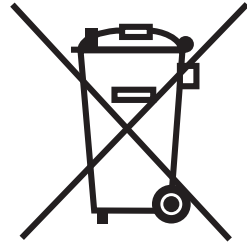

Wheelie Bin Logo

As the WEEE directive applies to self-contained operational electrical and electronic products, this end of life take back service does not refer to other Thorlabs products, such as:

Pure OEM products, that means assemblies to be built into a unit by the user (e.g. OEM laser driver cards)

Components

Mechanics and optics

Left over parts of units disassembled by the user (PCB's, housings etc.).

If you wish to return a Thorlabs unit for waste recovery, please contact Thorlabs or your nearest dealer for further information.

7.1. Waste Treatment is Your Own Responsibility

If you do not return an “end of life” unit to Thorlabs, you must hand it to a company specialized in waste recovery. Do not dispose of the unit in a litter bin or at a public waste disposal site.

7.2. Ecological Background

It is well known that WEEE pollutes the environment by releasing toxic products during decomposition. The aim of the European RoHS directive is to reduce the content of toxic substances in electronic products in the future.

The intent of the WEEE directive is to enforce the recycling of WEEE. A controlled recycling of end of life products will thereby avoid negative impacts on the environment.



THORLABS
www.thorlabs.com
