

AE0203D04

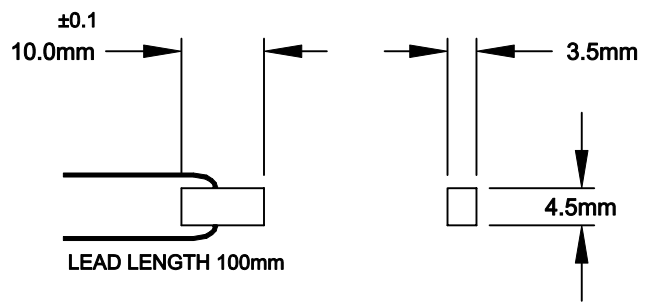

AE0203D08

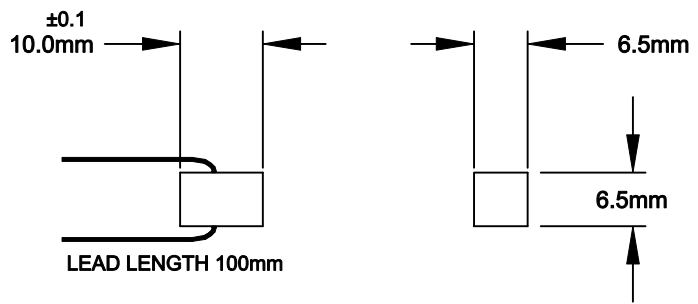

AE0505D08

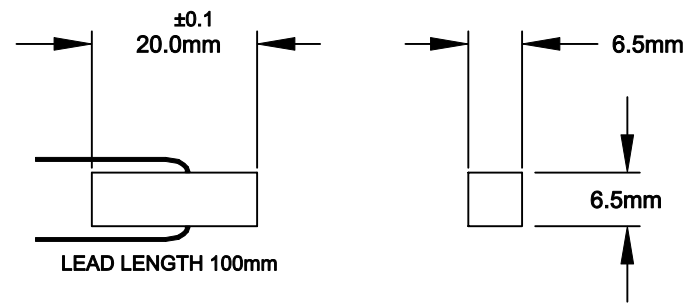

AE0505D16



NOTES;
RESIN COATED PIEZOELECTRIC CERAMIC

INFORMATION ONLY. NOT FOR MANUFACTURING

THORLABS			PO BOX 366 NEWTON NJ	
TITLE PIEZOELECTRIC ACTUATORS				
TOL: X.XXX=+/-0.005 X.XX=+/-0.010 ANGULAR +/-30'				
MATERIAL SEE NOTES			WHERE USED	
DRAWN TD	ENGR. AC	APPROVED		WEB MECHANICAL DRAWING
DATE 06/01/99	REV A	SIZE A	SHEET 1 OF 1	
DWG NO. 0820-E0W	PART NO. AE0505D16			