

FOR MORE INFORMATION SEE NEXT PAGES

FOR INFORMATION ONLY
NOT FOR MANUFACTURING PURPOSES

DRAWING PROJECTION			THORLABS www.thorlabs.com M² MEASUREMENT SYSTEM EXTENSION SET, 400-2700nm	
NAME	DATE			
DRAWN	Hit.	22/MAY/14	MATERIAL	
APPROVAL	RR	22/MAY/14		
COPYRIGHT © 2014 BY THORLABS			N/A	
VALUES IN PARENTHESIS ARE CALCULATED AND MAY CONTAIN ROUND OFF ERRORS			ITEM #	APPROX WEIGHT
			M2MS	4.2 kg
				REV A

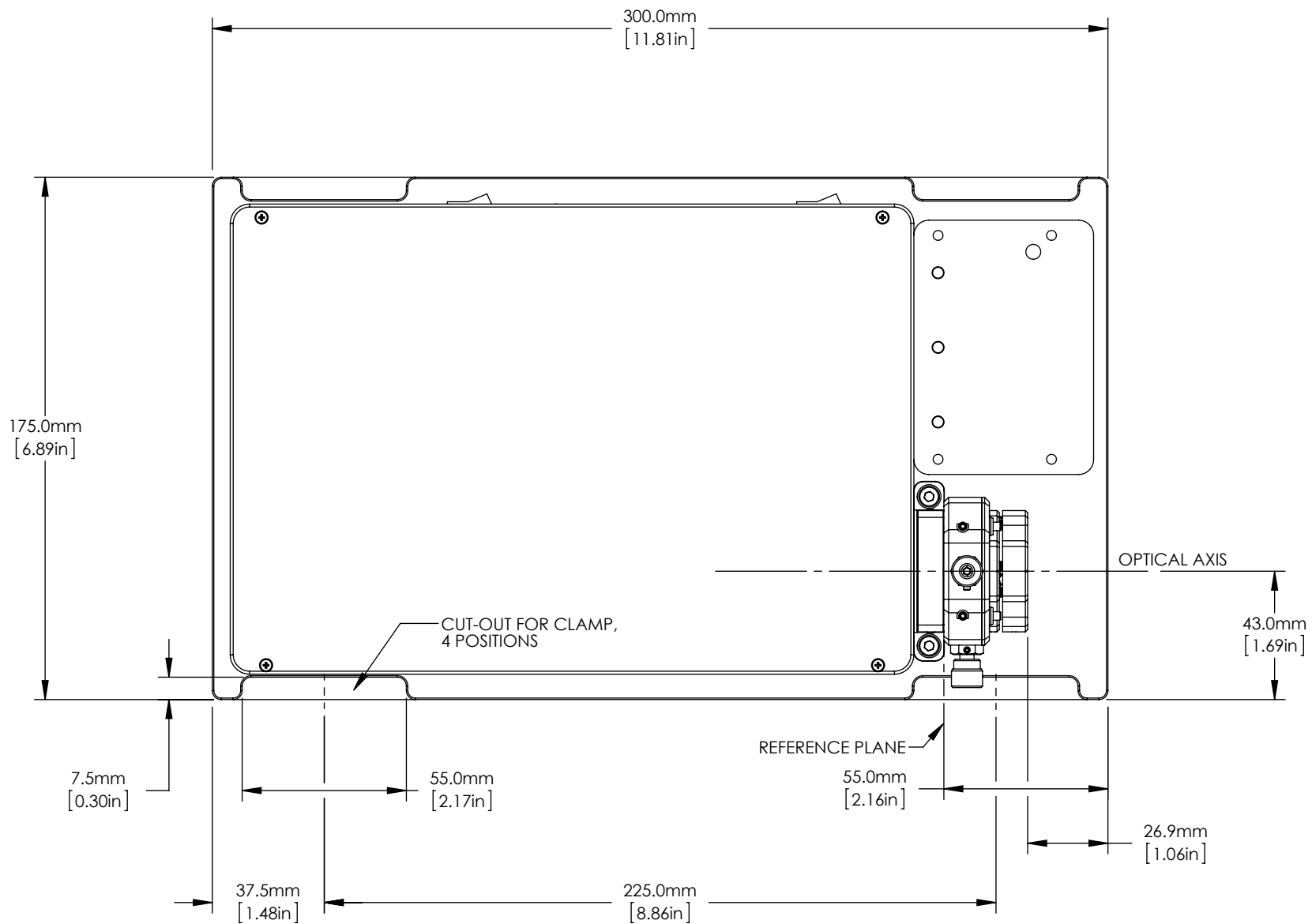

FOR INFORMATION ONLY
NOT FOR MANUFACTURING PURPOSES

DRAWING PROJECTION			THORLABS www.thorlabs.com	
NAME	DATE	M ² MEASUREMENT SYSTEM EXTENSION SET, 400-2700nm		
DRAWN	Hit.	22/MAY/14	MATERIAL	
APPROVAL	RR	22/MAY/14	N/A	
COPYRIGHT © 2014 BY THORLABS			ITEM #	APPROX WEIGHT
VALUES IN PARENTHESIS ARE CALCULATED AND MAY CONTAIN ROUND-OFF ERRORS			M2MS	4.2 kg
			REV	A

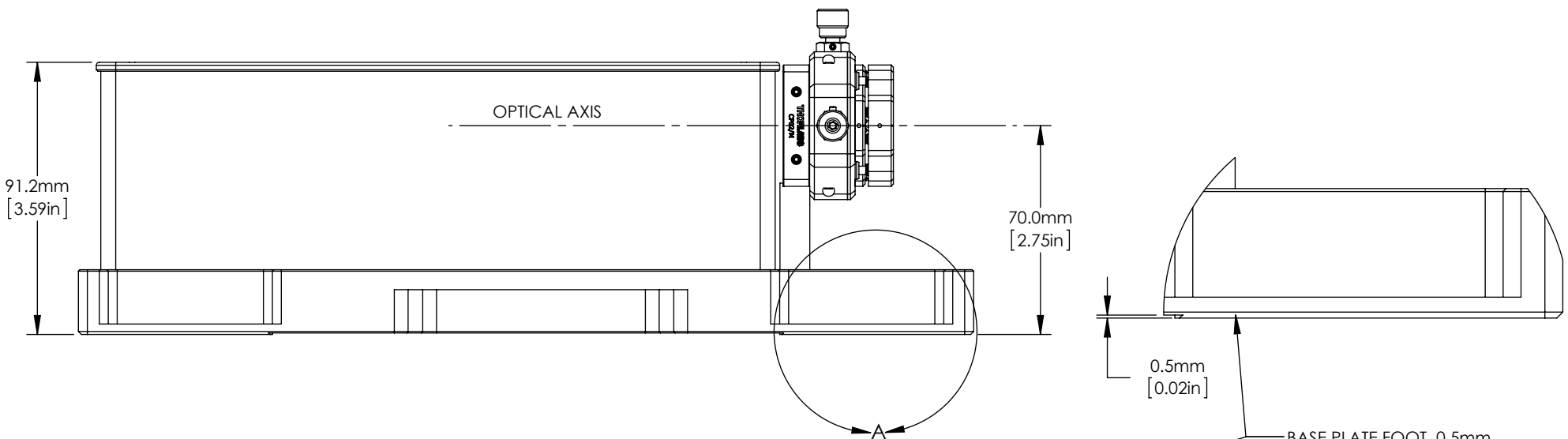

BASE PLATE FOOT, 0.5mm
HEIGHT, 4 POSITIONS
DETAIL A
SCALE 1 : 1

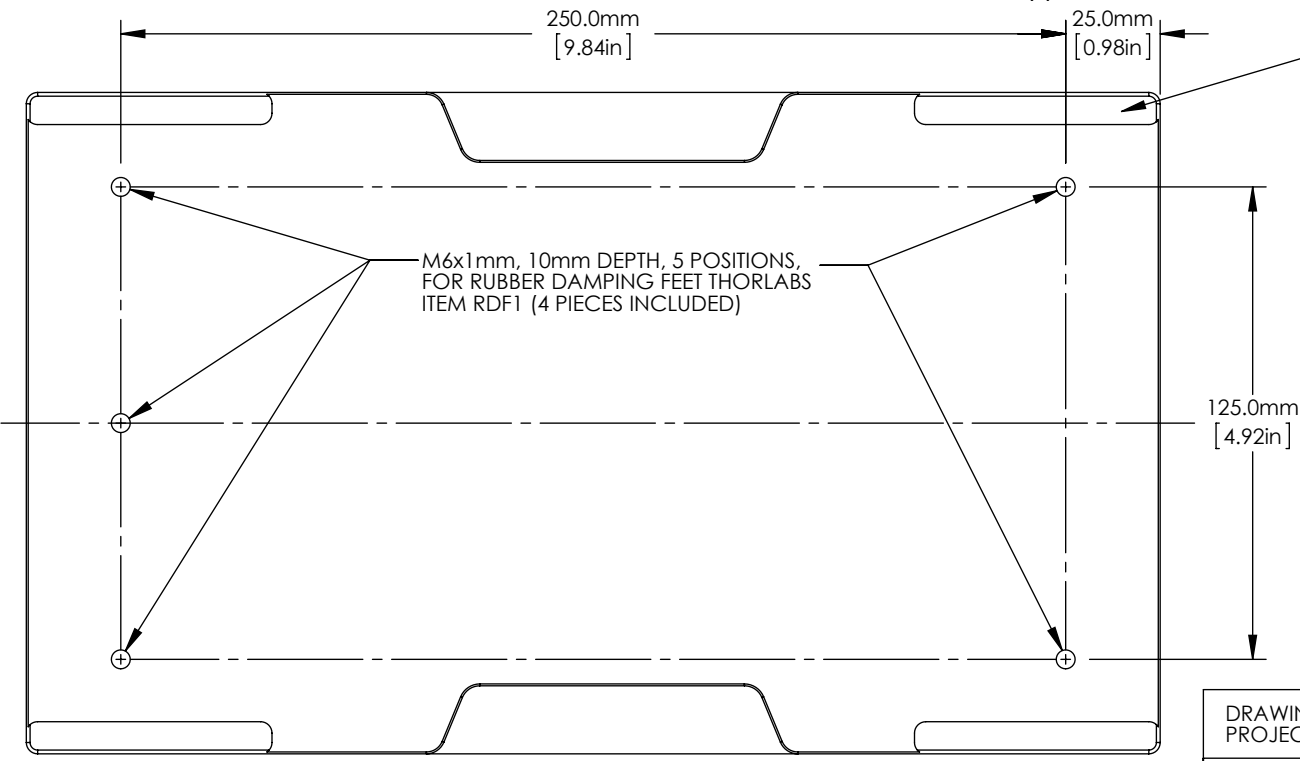

FOR INFORMATION ONLY
NOT FOR MANUFACTURING PURPOSES

DRAWING PROJECTION			THORLABS www.thorlabs.com	
NAME	DATE	M ² MEASUREMENT SYSTEM EXTENSION SET, 400-2700nm		
DRAWN	Hit.	22/MAY/14	MATERIAL	
APPROVAL	RR	22/MAY/14	N/A	REV A
COPYRIGHT © 2014 BY THORLABS			ITEM #	APPROX WEIGHT
VALUES IN PARENTHESIS ARE CALCULATED AND MAY CONTAIN ROUND OFF ERRORS			M2MS	4.2 kg

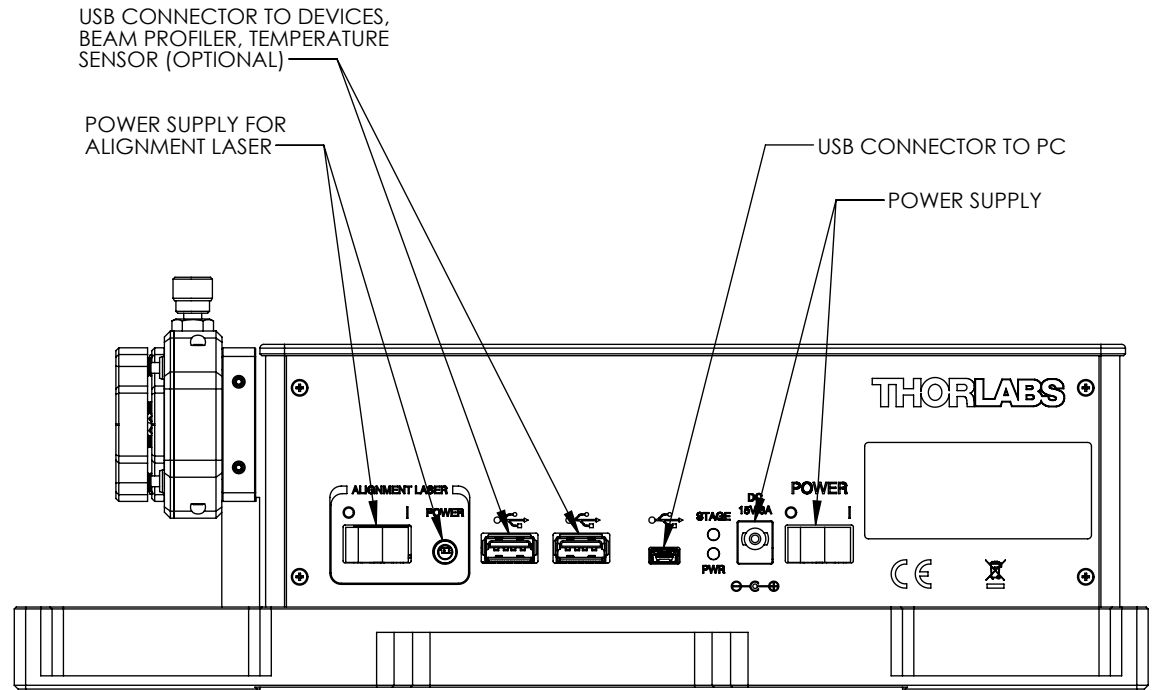
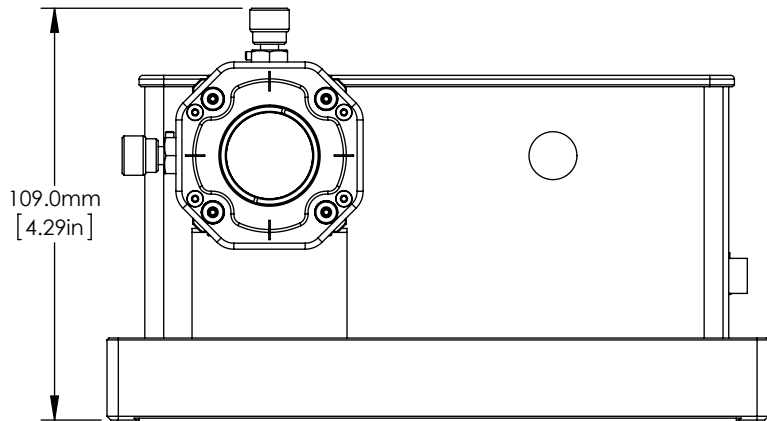

FOR INFORMATION ONLY
NOT FOR MANUFACTURING PURPOSES

DRAWING PROJECTION			 www.thorlabs.com M² MEASUREMENT SYSTEM EXTENSION SET, 400-2700nm	
	NAME	DATE		
DRAWN	Hit.	22/MAY/14	MATERIAL	
APPROVAL	RR	22/MAY/14		
COPYRIGHT © 2014 BY THORLABS			N/A	
VALUES IN PARENTHESIS ARE CALCULATED AND MAY CONTAIN ROUND OFF ERRORS			ITEM #	APPROX WEIGHT
			M2MS	4.2 kg

REV
A

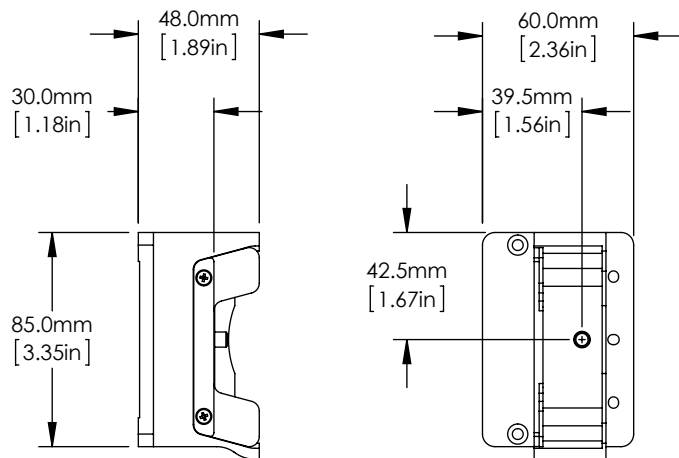
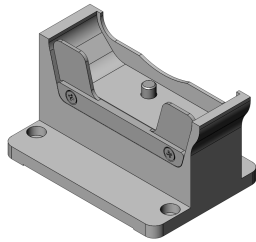

MOUNT FOR BC106 SERIES

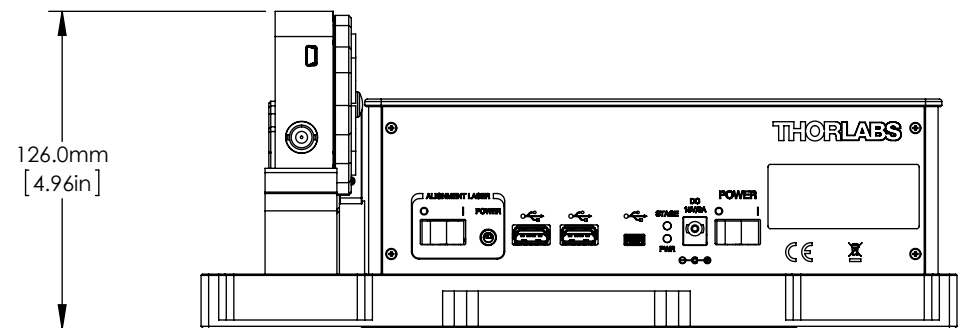

WITH MOUNTED BC106 (NOT INCLUDED)

FOR INFORMATION ONLY
NOT FOR MANUFACTURING PURPOSES

DRAWING PROJECTION			THORLABS www.thorlabs.com M² MEASUREMENT SYSTEM EXTENSION SET, 400-2700nm	
NAME	DATE			
DRAWN	Hit.	22/MAY/14	MATERIAL	
APPROVAL	RR	22/MAY/14		
COPYRIGHT © 2014 BY THORLABS			N/A	
VALUES IN PARENTHESIS ARE CALCULATED AND MAY CONTAIN ROUND OFF ERRORS			ITEM #	APPROX WEIGHT
			M2MS	4.2 kg
				REV A

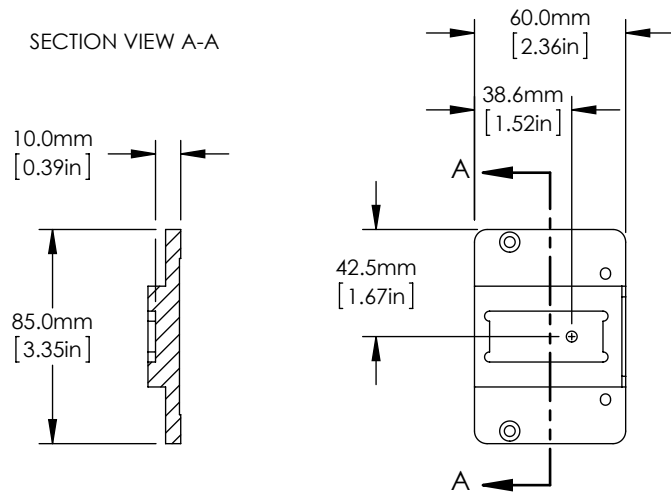
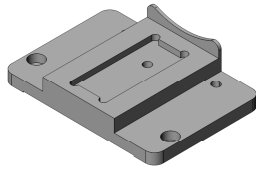

MOUNT FOR BP100 AND BP209 SERIES

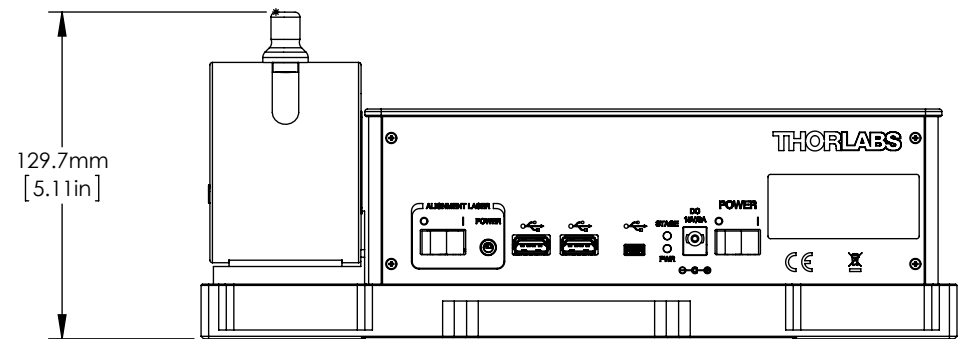

WITH MOUNTED BP209 (NOT INCLUDED)

FOR INFORMATION ONLY
NOT FOR MANUFACTURING PURPOSES

DRAWING PROJECTION			THORLABS www.thorlabs.com M² MEASUREMENT SYSTEM EXTENSION SET, 400-2700nm	
NAME	DATE			
DRAWN	Hit.	22/MAY/14	MATERIAL	
APPROVAL	RR	22/MAY/14		
COPYRIGHT © 2014 BY THORLABS			N/A	
VALUES IN PARENTHESIS ARE CALCULATED AND MAY CONTAIN ROUND OFF ERRORS			ITEM #	APPROX WEIGHT
			M2MS	4.2 kg
				REV A