

F9J "	89G7 F-DHC B.	B5A 9#85H9.

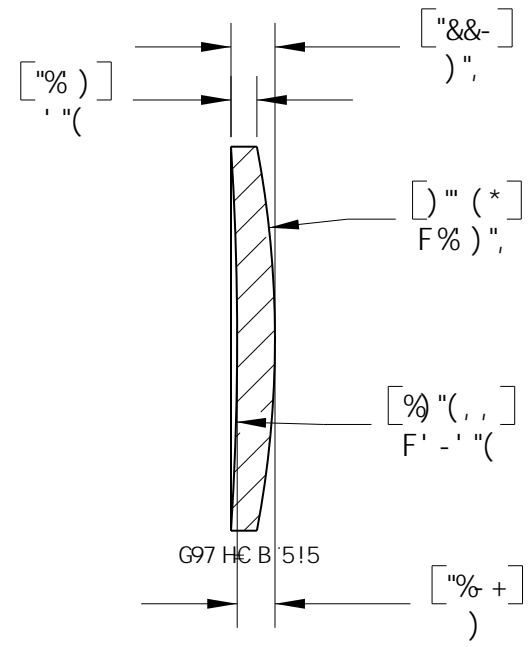
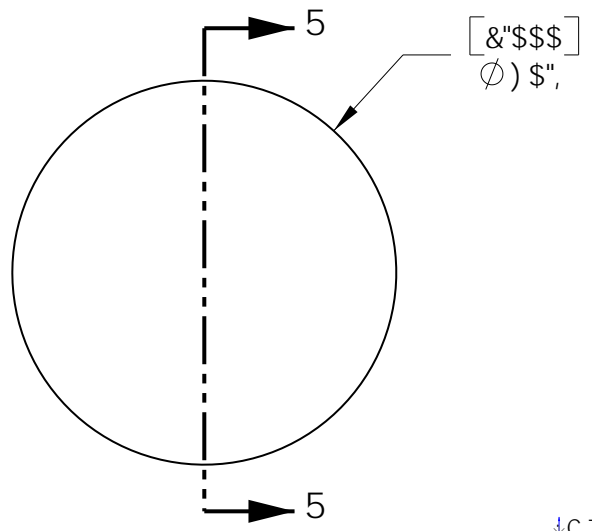

I B7C5H98

*C 75@@B; Hk. (\$"\$a a
657?: C 75@ ' -) "\$a a
B89L. %) %' 4 *' ' ba
89G= B' K 5J 9@B; Hk. ' *' ' ba
G7 F5H7 <#8 = '(\$&\$
8-5A 9H9F HC @F5B79. Ž"\$a a # "\$%\$a a
7 @95F '5D9FH F9. O- \$i
7 9BH5HC B. ' '5F7 'A B
7 9BH9F 'Hk-? B9CGHC @F5B79. '-\$%a a
7 <5A : 9F '\$&\$a a '5H() \$'5@G<5FD'98; 9G
98: 9Hk-? B9CG5GGI A B; 'G<5FD'98; 9
5B8; ∫ 9B '69. C F97 <5A : 9F

BCH9.
: CF 'B: CFA 5HC B' CB@M
BCH: CF'A 5BI : 57H F-B;

5@I B+G; ∫ 9B 'B'A @A 9HFG

HC@F5B79G	B5A 9	85H9
I B@GGCH: 9FK @9 GD97 = 98.	8F5K B	5D) #8) #&\$ \$*
8-A 9BGC BG5F9-B 'B7 <9G	9B: '5DDF"	HC) #8) #&\$ \$*
@B95F HC@F5B79G	A:: '5DDF"	HC) #8) #&\$ \$*
...Hk C D@579897-A 5@ ±\$"\$%	DFC DF-96FM5B87CB: -98H5@	
...Hk F99D@579897-A 5@ ±\$"\$%	Hk-9 B: CFA 5HC B' 7C B15-B98 'B Hk-G	
5B: I @5F. '±' \$F"	8F5K B: '6Hk-9GC @DFC D9F HMC:	
GI F: 579: B-G<." &A =FC-B7 <9G	Hk C F@56Gz-B7 " '5BMF9DFC 8I 7HC B	
D5F5@9@CA. '\$\$\$&	B D5FHC F 5G5 K <C @K Hk C I H	
: @5HB9CG '\$\$\$&	Hk-9K F+H9B 'D9FA @GC B C:	
GF5 = <H9CG '\$\$\$&	Hk C F@56Gz-B7 " @DFC <-6+H8"	
7C B7 9BHF =7 HM '\$\$\$&		
D9FD9B 8-7I @5F+M '\$\$\$&		
Hk F958. 7 @5GG&: #I		

Hk C F @56Gz-B7 " DC '6CL" **	
B9K HC B' B>	
H#I@.	
«) \$", a a '6?+ 'DC G+H 9'A -BI @7I G @9BG	
A 5H9F 5@	G+H 9' 5
6?+ž: fUXY '5	F9J " 5
G7 5@. %%	G<99H% C: %
8K ; "'BC "	D5FH'BC "
' (*, !9\$%	@9%) -