

FIBER SPECIFICATIONS\*

FIBER TYPE	CORE DIAMETER	CLADDING DIAMETER**	COATING DIAMETER	NA	OPERATING WAVELENGTH
FG105LCA	105 +1/-3 μm	125 +1/-2 μm	250 ±10 μm	0.22 ± 0.02	400 - 2400 nm

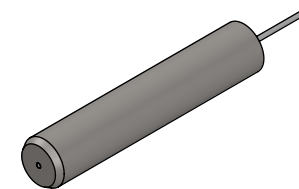

ISOMETRIC VIEW  
SCALE 6:1

\*SPECIFICATIONS BASED ON BARE-FIBER DATA

\*\* OUTER DIAMETER OF FIBER PROTRUDING FROM FERRULE

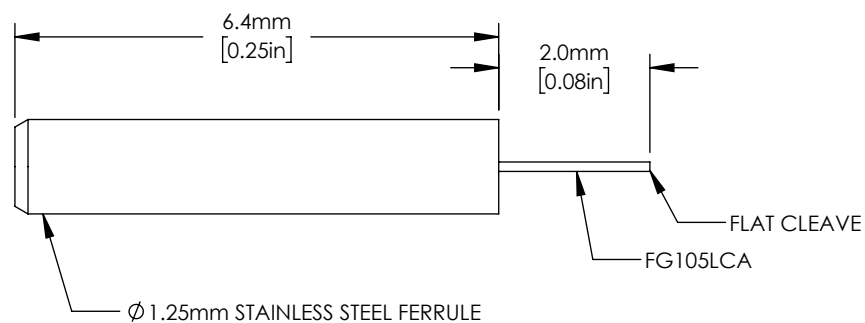

\*INCLUDED BUT NOT SHOWN:  
1 PROTECTIVE DUST CAP

FOR INFORMATION ONLY  
NOT FOR MANUFACTURING PURPOSES

DRAWING PROJECTION			 www.thorlabs.com	
	NAME	DATE		
DRAWN	JL	07/MAY/15	1.25mm STAINLSS FIBER OPTIC CANNULA 105 μm, 0.22NA, 2mm LONG	
APPROVAL	HC	19/APR/22	MATERIAL	REV C
COPYRIGHT © 2017 BY THORLABS			N/A	
VALUES IN PARENTHESIS ARE CALCULATED AND MAY CONTAIN ROUND OFF ERRORS			ITEM #	APPROX WEIGHT
			CFML21L02	0.04g