

## SM05PD7B Mounted GaP-Photodiode

High Speed  
High Responsivity

The SM05PD7B is a high-speed mounted GaP-Photodiode with a spectral response from 150nm to 550nm. This photodiode has a Schottky barrier structure that provides fast Rise Time (1ns) and Fall Times (140ns) with a bias of -5V. The SM05PD7B is compatible with all Thorlabs SM05 Mounting components.

### Electrical Characteristics:

Spectral Response:	150 - 550 nm
Active Area:	4.8mm <sup>2</sup>
Rise Time (R <sub>L</sub> = 50Ω):	1 ns (-5V bias)
Fall Time (R <sub>L</sub> = 50Ω):	140 ns (-5V bias)
NEP @ 440 nm:	1 x 10 <sup>-14</sup> W/√Hz (@ -5V bias)
Dark Current:	10nA max. (-5V)

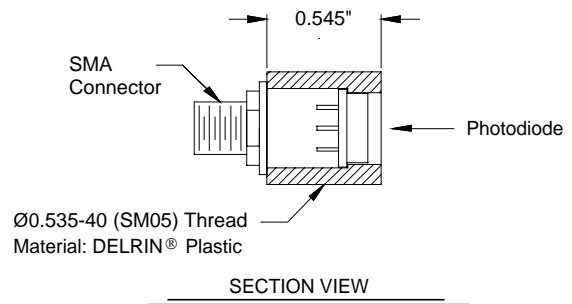

### Maximum Ratings:

Damage Threshold CW:	100 mW/cm <sup>2</sup>
Damage 10ns Pulse:	500 mJ/cm <sup>2</sup>
Max Bias Voltage:	-10 V

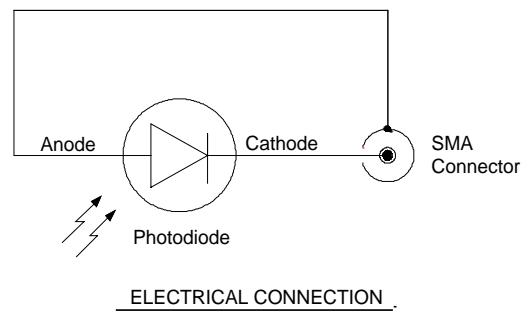

The Thorlabs SM05PD7B Mounted GaP-Photodiode is ideal for measuring both pulsed and CW light sources, by absorption of photons or charged particles and generate a flow of current in an external circuit, proportional to the incident power. The photodiode anode produces a current, which is a function of the incident light power (P) and the wavelength (λ). The responsivity R<sub>λ</sub>, can be read from Fig. 1 to estimate the amount of photocurrent to expect. This can be converted to a voltage by placing a load resistor (R<sub>L</sub>) from the photodiode anode to the circuit ground. The output voltage is derived as:

$$V_0 = P \cdot R_\lambda \cdot R_L$$

The bandwidth (f<sub>BW</sub>) and the rise time response (t<sub>R</sub>), are determined from the diode capacitance (C<sub>J</sub>) and the load resistance (R<sub>L</sub>) as shown below. Placing a bias voltage from the photo diode cathode to the circuit ground can lower the photo diode capacitance.

$$f_{BW} = \frac{1}{2\pi \cdot R_L \cdot C_J} \qquad t_R \cong \frac{0.35}{f_{BW}}$$

### Typical Circuit Diagram:

Application of a reverse bias (i.e. cathode positive, anode negative) can greatly improve the speed of response and linearity of the devices. This is due to increase in the depletion region width and consequently decrease in junction capacitance. Applying a reverse bias, however, will increase the dark and noise currents.

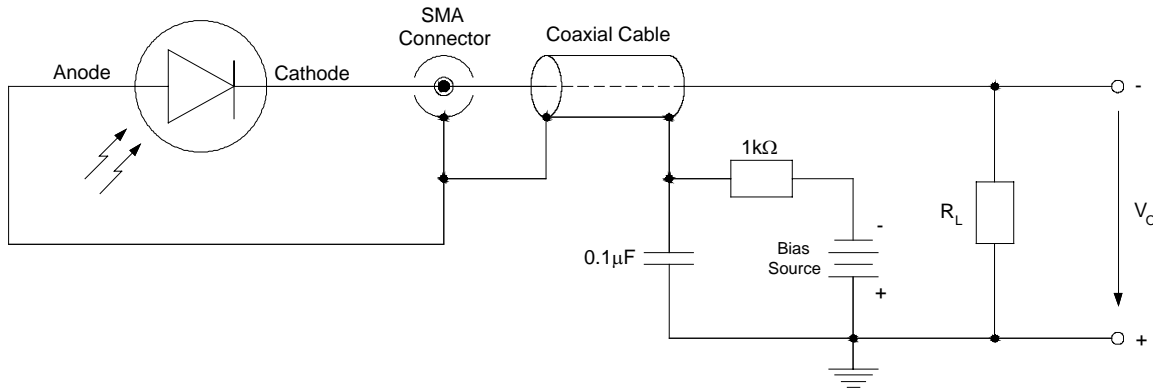

The photodiode output can be either directly connected to an oscilloscope or fed to a fast response amplifier.

### Spectral Responsivity:

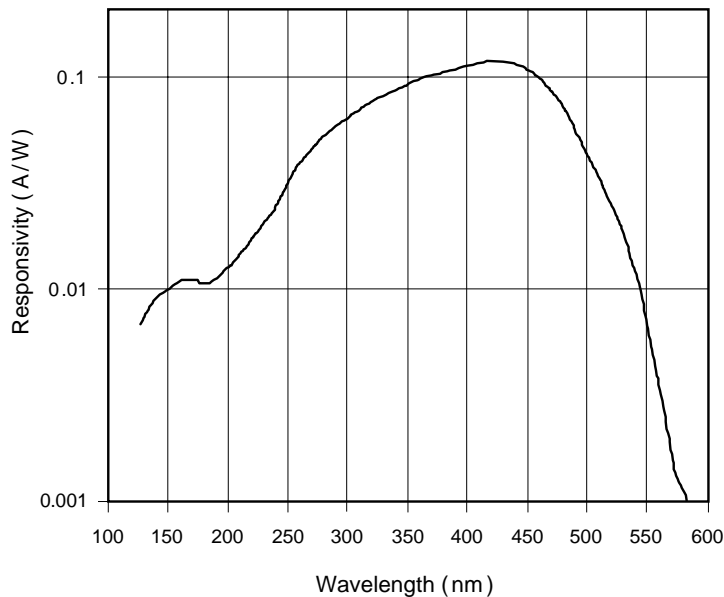

Fig. 1: Spectral Responsivity of SM05PD7B Mounted GaP-Photodiode

The responsivity of a photodiode is a measure of the sensitivity to light, and it is defined as the ratio of the photocurrent  $I_P$  to the incident light power  $P$  at a given wavelength:

$$R_{\lambda} = \frac{I_P}{P}$$

In other words, it is a measure of the effectiveness of the conversion of the light power into electrical Current. It varies with the wavelength of the incident light as well as applied reverse bias and temperature. Responsivity increases slightly with applied reverse bias due to improved charge collection efficiency in photodiode.

Also there are responsivity variations due to change in temperature, this is due to decrease or increase of the band gap, because of increase or decrease in the temperature respectively. Spectral responsivity may vary from lot to lot and it is dependent on wavelength. However, the relative variations in responsivity can be reduced to less than 1% on a selected basis.