

PA4FEH3W

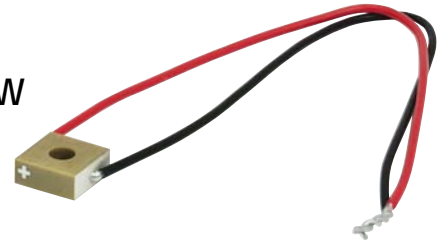

Description

The PA4FEH3W piezoelectric chip with insulated $\varnothing 2$ mm inner hole consists of stacked piezoelectric ceramic layers (which are mechanically in series) that are sandwiched between interdigitated electrodes (which are electrically in parallel). It offers a maximum displacement of $1.8 \mu\text{m} \pm 15\%$. A red wire is located next to the electrode that should receive positive bias; the other electrode should be grounded.

Specifications

PA4FEH3W ^a	
Drive Voltage Range	0 - 150 V
Displacement (Free Stroke ^b) at 150 V	$1.8 \mu\text{m} \pm 15\%$
Hysteresis	<15% (See Graph on Next Page)
Load (Recommended)	300 N (68 lbs)
Blocking Force at 150 V	800 N (180 lbs)
Resonant Frequency ^c	610 kHz (No Load)
Impedance at Resonant Frequency ^c	200 m Ω
Anti-Resonant Frequency ^c	820 kHz
Dissipation Factor	<2.0%
Capacitance	160 nF $\pm 15\%$
Operating Temperature	-25 to 130 °C
Curie Temperature	230 °C
External Electrodes	Screen-Printed Silver
Dimensions	Hole diameter: 2.0 mm ± 0.1 mm Width 1: 5.0 mm ± 0.1 mm Width 2: 5.0 mm ± 0.1 mm Length: 2.0 mm $\pm 5 \mu\text{m}$

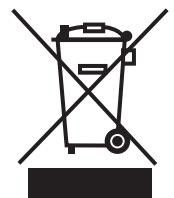

- All specifications are quoted at 25 °C, unless otherwise stated.
- This chip is designed to produce maximum displacement when used with the recommended load. The displacement may vary slightly for different loads.
- These specifications are for the unwired chip.

Drawing

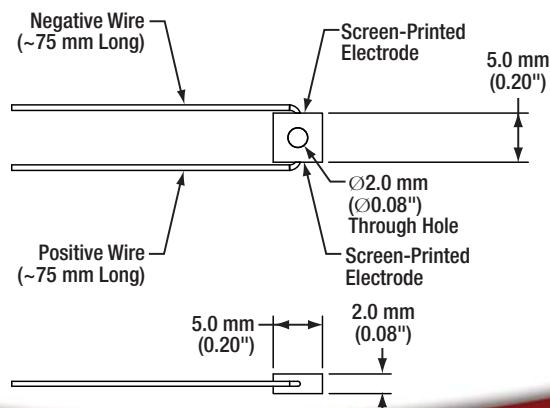

Typical Performance Plots

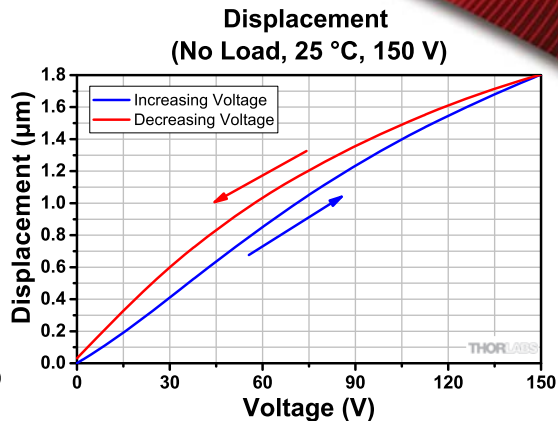
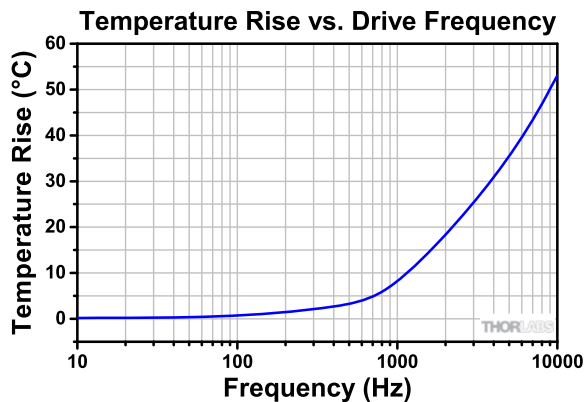

These temperature rises were measured after applying a sine-wave drive voltage ranging from 0 to 150 V at the specified frequency for 10 minutes.

Operation

Electrical Considerations

- The electrode closest to the + Mark should be positively biased, and the opposite electrode should be grounded. The maximum drive voltage is 150 V. Exceeding 150 V will decrease the device's lifespan and may cause mechanical failure. Reverse biasing the device may cause mechanical failure.
- When soldering wires to the electrodes, use a temperature no greater than 370 °C (700 °F) for a maximum of 2 seconds per spot. Solder to the middle of the electrode, keeping the spot as small as possible.
- Caution: after driving, the piezo is fully charged. Directly connecting the red and black wires has the risk of electricity discharging, spark, and even failure. We recommend using a resistor (>1 kΩ) between the wires to release the charge.

Attaching Devices to the Piezo

- Any epoxy which cures at a temperature lower than 80 °C is safe to use. We recommend Thorlabs Item Numbers 353NDPK or TS10. Loctite Hysol 9340 is also usable.
- Loads should only be attached to the central area of the largest face since the edges do not translate. Attaching a load to the smaller faces may lead to mechanical failure.

Storage Instructions

- Do not store the device at temperatures above 80 °C.
- Do not store the device in humid environments. The relative humidity (RH) should be less than 40%.
- Do not immerse the device in organic solvents.
- Do not use the device around combustible gases or liquids.