

F9J "	89G7 F-DHC B.	B5A 9#85H9.

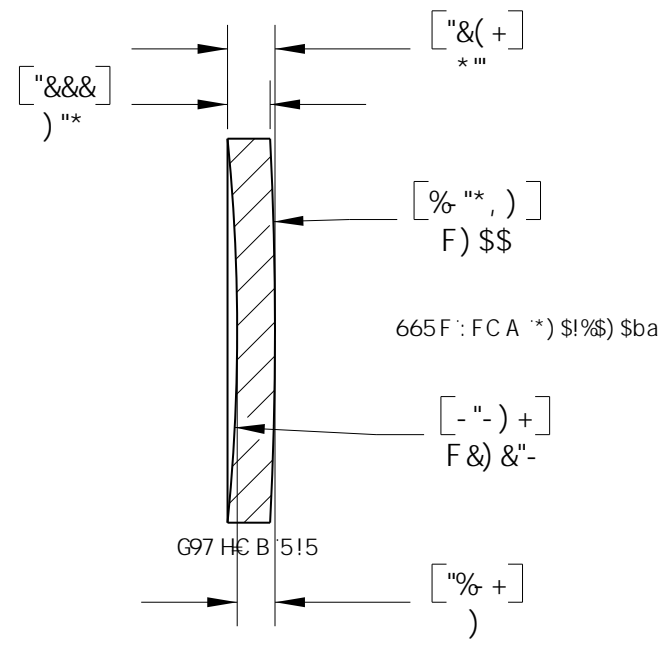
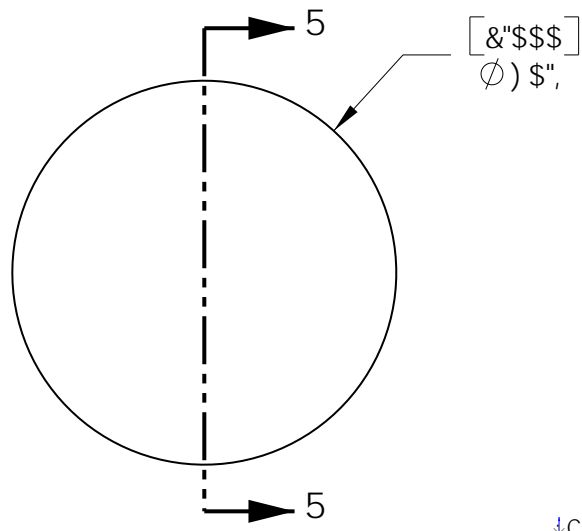

\*C 75@@B; Hk. !%\$\$\$a a  
657?: C 75@ !- \*\"+a a  
B 89L. %) %' 4 \*\"' ba  
89G= B 'K 5J 9@B; Hk. \*\"' ba  
G7 F5H7 <#8 = .( \$&\$  
8-5A 9HF HC @F 5B 79. Ž\$\"\$\$a a # \"\$%\$a a  
7 @95F 5D9FH F9. O- \$i  
7 9BH5HC B. ' 5F7 'A B  
7 9BH9F 'H- ? 7 B9GGHC @F 5B 79. - \"\$% a  
7 <5A : 9F '\$&\$a a '5H( ) \$5@G<5FD'98; 9G  
98; 9H- ? 7 B9GG5GG A B; 'G<5FD'98; 9  
5B8; 9B '69. C F97 <5A : 9F

BCH9.  
: CF 'B: CFA 5HC B 'CB@M  
BCH: CF 'A 5BI : 57H F-B;

5@I B+G; 9B 'B 'A @A 9HFG

HC @F 5B 7 9G	B5A 9	85H9
1 B@9GGCH: 9FK @9 GD97 = 98.	8F5K B	5D ) #& #&\$ \$*
8-A 9BGC BG5F9-B 'B7 <9G	9B: '5DDF"	HC ) #& #&\$ \$*
@B95F HC @F 5B 7 9G	A : '5DDF"	HC ) #& #&\$ \$*
... Hk C D@57 9897-A 5@ ±\$ \$%\$	<b>DFC DF-96FM5B8 7CB: -98H5@</b>	
... Hk F99D@57 9897-A 5@ ±\$ \$%\$	Hk 9 B: CFA 5HC B 7 C B H5 B 98 B Hk G	8F5K B: 'GH: 9GC @DFC D9F HMC:
5B: 1 @5F. '±' \$H'	Hk C F @5 6Gz-B 7 " 5B MF 9DFC 8I 7 HC B	B D5FHC F 5G5 K <C @K Hk C I H
GI F: 57 9: B-G<." & A 7 FC-B7 <9G	Hk 9K F H9B D9FA GGC B C:	Hk C F @5 6Gz-B 7 " 4DFC <6+98"
D5F5 @9@CA. '\$ \$&&		
: @5B 9CG '\$ \$&&		
GF 5 = <H 9CG '\$ \$&&		
7 C B 7 9B HF 7 H M '\$ \$&&		
D9F D9B 8-7 1 @5F H M '\$ \$&&		
Hk F 95 8. 7 @5GG &: #		

Hk C F @5 6Gz-B 7 " DC '6CL" **	
B 9K HC B 'B >	
H# @.	
« ) \$\", a a '6? + 'B9; 5HJ 9'A 9B-G7 I G@9B G	
A 5H9F 5@	G#9 F9J "
6? +ž; fUXY '5	5 5
G7 5@. %%	G< 99H% C: %
8K ; " "BC"	D5FH'BC "
(- \$(19\$%	@ % - %6