

REVISIONS			
REV.	DESCRIPTION	DATE	DCN NO
-	FOR QUOTING PURPOSES ONLY		

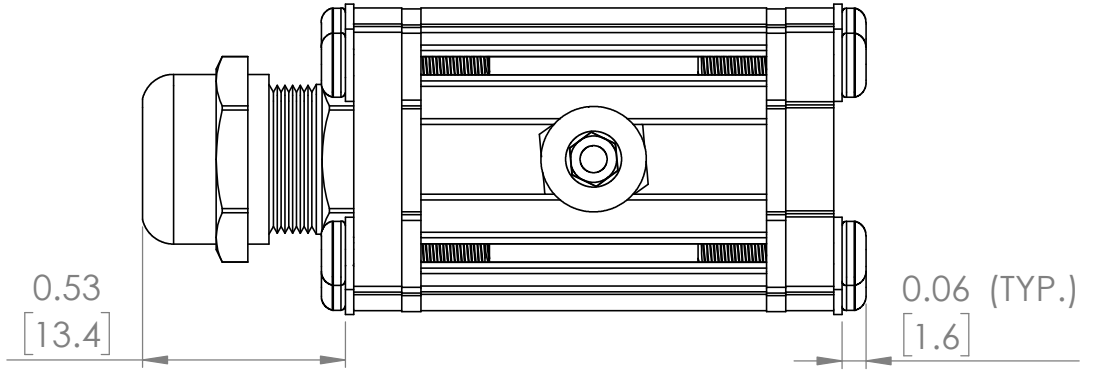

M4 MOUNTING SCREW

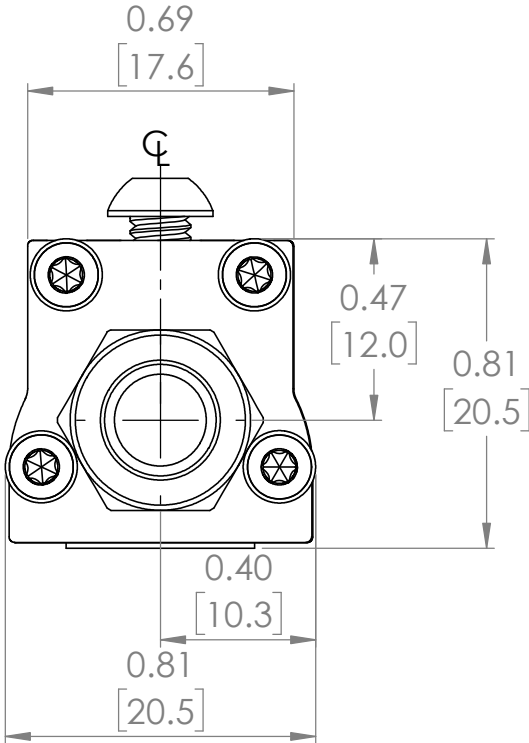
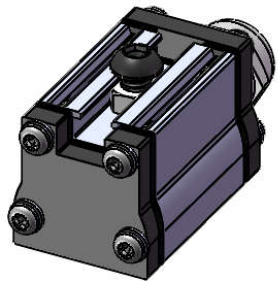
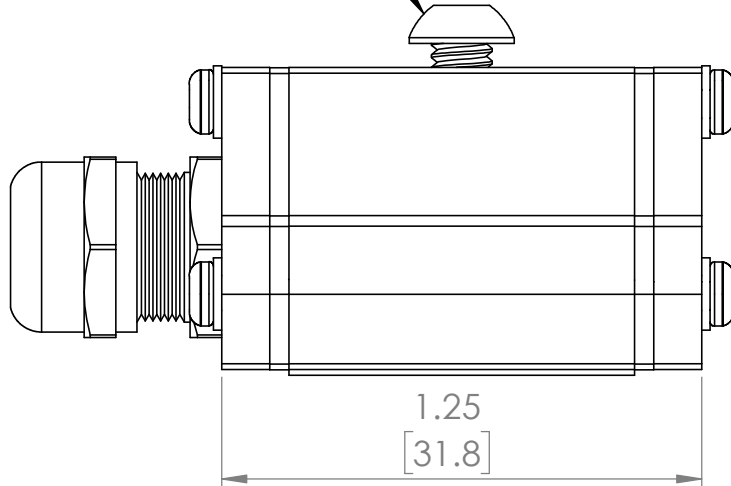

FOR REFERENCE ONLY

PROPRIETARY AND CONFIDENTIAL
 THESE DRAWINGS AND SPECIFICATIONS ARE THE EXCLUSIVE PROPERTIES OF ADVANCED ILLUMINATION INCORPORATED ISSUED IN STRICT CONFIDENCE AND SHALL NOT, WITHOUT THE PRIOR WRITTEN PERMISSION OF ADVANCED ILLUMINATION INC BE REPRODUCED, COPIED OR USED FOR ANY PURPOSE WHATSOEVER EXCEPT FOR THE MANUFACTURE OF ARTICLES FOR ADVANCED ILLUMINATION INC

CUT USING: -		UNLESS OTHERWISE SPECIFIED:		DATE	NAME	ADVANCED ILLUMINATION 440 STATE GARAGE ROAD, ROCHESTER, VERMONT 05767
		SURFACE SHOULD BE FREE OF SCRATCHES, BURRS, AND DENTS		11-JUN-18	T.MILLS	
		DIMENSIONS ARE IN: INCHES		CHECKED	--	TITLE: DRAWING, INSTALLATION, SL243 (SEALED)
		<u>TOLERANCES</u>		APPROVED	--	
NEXT ASSY		USED ON		MATERIAL		SIZE DWG. NO. REV A SL243 (SEALED) -
APPLICATION				AS NOTED ON INDIVIDUAL DRWS		
		FRACTIONAL ± 1/16		FINISH		SCALE: NTS/C CODE: - SHEET 1 OF 1
		ANGULAR: MACH ± 1 BEND ± 1		AS NOTED ON INDIVIDUAL DRWS		
		TWO PLACE DECIMAL ± .010				
		THREE PLACE DECIMAL ± .005				
		MAKE FROM				