

NOTES:

1. SUBSTRATE: UV GRADE FUSED SILICA
2. COATING (APPLY ACROSS CLEAR APERTURE)
S1 & S2: RAVG ≤0.5% @ 600 - 1050nm
3. SURFACE S2 TO BE PARALLEL WITH S1 TO WITHIN <5 ARCSEC

 FINE GRIND SURFACE

5. RoHS COMPLIANT

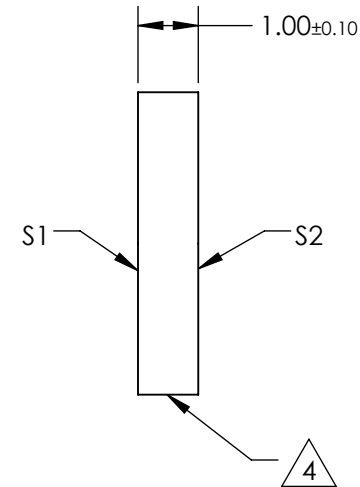
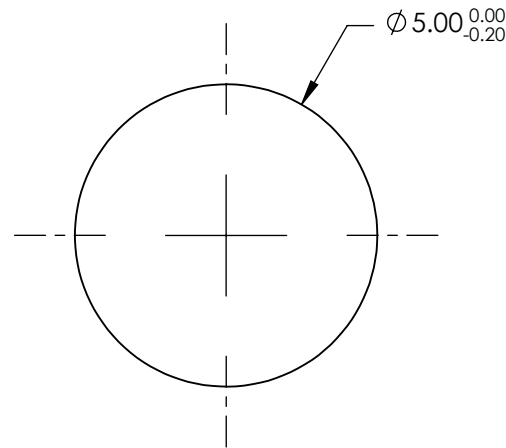
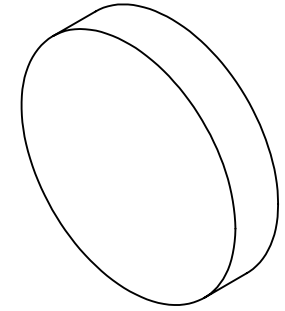

**FOR INFORMATION ONLY:
DO NOT MANUFACTURE
PARTS TO THIS DRAWING**

SPECIFICATIONS SUBJECT TO CHANGE WITHOUT NOTICE
DIMENSIONS ARE FOR REFERENCE ONLY

	S1	S2
SHAPE	PLANO	PLANO
SURFACE QUALITY	20-10	20-10
CLEAR APERTURE	Ø4.00	Ø4.00
BEVEL	PROTECTIVE AS NEEDED	PROTECTIVE AS NEEDED

THIRD ANGLE PROJECTION 

ALL DIMS IN mm

 **Edmund Optics®**

TITLE

5mm DIA., 1mm THICK, NIR I COATED λ/10
FUSED SILICA WINDOW

DWG NO

84459

SHEET
1 OF 1