

NOTES:

1. SUBSTRATE MATERIAL:
B270
2. SURFACE S1 TO BE PARALLEL TO SURFACE S2 TO WITHIN <3 ARCMIN
3. COATING (APPLY ACROSS COATING APERTURE)
S1: Square Aluminum (AlMgF2) Apertures
R: 30±5% @ 400 - 2000nm @ 45° AOI
T: 70±5% @ 400 - 2000nm @ 45° AOI
S2: NONE
4. POLKA DOT CENTER TO CENTER SPACING : 0.15mm
POLKA DOT MINIMUM APERTURE: 2mm
5. ROHS : COMPLIANT

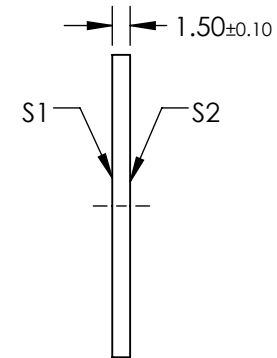
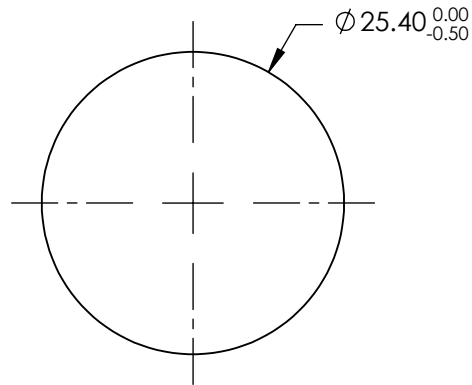
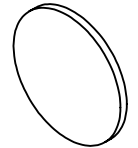

**FOR INFORMATION ONLY:
DO NOT MANUFACTURE
PARTS TO THIS DRAWING**

SPECIFICATIONS SUBJECT TO CHANGE WITHOUT NOTICE
DIMENSIONS ARE FOR REFERENCE ONLY

EO® Edmund Optics®

	S1	S2
SHAPE	PLANO	PLANO
SURFACE QUALITY	80-50	80-50
CLEAR APERTURE	90%	90%
BEVEL	PROTECTIVE AS NEEDED	PROTECTIVE AS NEEDED

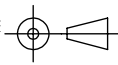
THIRD ANGLE PROJECTION 

ALL DIMS IN mm

TITLE	25.4mm DIA 30R/70T, VIS-NIR POLKA-DOT BEAMSPLITTER	
DWG NO	15985	SHEET 1 OF 1