



Balance Amplified Photodetectors

PDB4xx Series Operation Manual



2014

Version: 2.0
Date: 20-Nov-2014

Contents

Foreword	2
1 General Information	3
1.1 Safety	3
1.2 Ordering Codes and Accessories	3
2 Installation	4
2.1 Parts List	4
2.2 Getting Started	4
3 Operating Instruction	5
3.1 Operating Principle	5
3.2 Optical Inputs	6
3.3 Electrical Outputs	8
3.4 Mounting	9
3.5 AC Coupling of the Outputs	10
3.6 CMRR and Frequency Response	11
3.7 Recommendations	12
4 Maintenance and Service	13
5 Appendix	14
5.1 Technical Data	15
5.1.1 PDB410x Individual Technical Data	18
5.1.2 PDB420x Individual Technical Data	21
5.1.3 PDB430x Individual Technical Data	24
5.1.4 PDB440x Individual Technical Data	27
5.1.5 PDB450x Individual Technical Data	30
5.1.6 PDB460x Individual Technical Data	33
5.2 Dimensions	36
5.3 Certifications and Compliances	38
5.4 Warranty	39
5.5 Copyright and Exclusion of Reliability	40
5.6 Thorlabs 'End of Life' Policy (WEEE)	41
5.7 Thorlabs Worldwide Contacts	42

We aim to develop and produce the best solution for your application in the field of optical measurement technique. To help us to live up to your expectations and improve our products permanently we need your ideas and suggestions. Therefore, please let us know about possible criticism or ideas. We and our international partners are looking forward to hearing from you.

Thorlabs GmbH

Warning

Sections marked by this symbol explain dangers that might result in personal injury or death. Always read the associated information carefully, before performing the indicated procedure.

Attention

Paragraphs preceded by this symbol explain hazards that could damage the instrument and the connected equipment or may cause loss of data.

Note

This manual also contains "NOTES" and "HINTS" written in this form.

Please read these advices carefully!

1 General Information

Thorlabs PDB4xx Series Balanced Amplified Photodetectors consist of two well-matched photodiodes and an ultra-low noise, high-speed transimpedance amplifier that generates an output voltage (RF OUTPUT) proportional to the difference between the photo currents in the two photodiodes, i.e. the two optical input signals. Additionally, the unit has two fast monitor outputs (MONITOR+ and MONITOR-) to measure the individual optical input power level as well as low frequency modulated signals on each detector separately.

To the PDB4xx Series housing an adapter can be attached to the bottom or side surface for post mounting. This adapter supports #8-32 as well as M4 post mounts.

The PDB4xx Series is supplied with an external linear power supply.

The [“Getting Started”](#)^[4] section gives an overview of how to set up the PDB4xx Series Balanced Amplified Photodetectors. Subsequent sections contain detailed information about principle of operation, operating suggestions, and technical specifications.

1.1 Safety

Attention

All statements regarding safety of operation and technical data in this instruction manual will only apply when the unit is operated correctly as it was designed for.

All modules must only be operated with proper shielded connection cables.

Only with written consent from *Thorlabs* may changes to single components be carried out or components not supplied by *Thorlabs* be used.

This precision device is only serviceable if properly packed into the complete original packaging including the plastic foam sleeves. If necessary, ask for a replacement package.

1.2 Ordering Codes and Accessories

The following models of the PDB4xx Series are available:

PDB410	100 MHz, fixed gain Balanced Amplified Photodetectors
PDB420	75 MHz, OCT-proved fixed gain Balanced Amplified Photodetectors
PDB430	350 MHz, fixed gain Balanced Amplified Photodetectors
PDB440	15 MHz, OCT-proved fixed gain Balanced Amplified Photodetectors with active aliasing filter
PDB450	150 MHz, gain switchable Balanced Amplified Photodetectors
PDB460	200 MHz, fixed gain Balanced Amplified Photodetectors

According to Thorlabs general detector part numbering system, the suffix “A” indicates Si photodiodes while the suffix “C” indicates InGaAs photodiodes.

Thorlabs offers AC-coupled versions. on request Special versions (open detector - cover glass removed) are available - except PDB430C and PDB460C - as well - please contact [Thorlabs](#)^[42] for details.

2 Installation

This section is intended to provide information that explains how to quickly set up the PDB4xx Series Balanced Amplified Photodetectors. More details and advanced features are described in further sections.

2.1 Parts List

Inspect the shipping container for damage.

If the shipping container seems to be damaged, keep it until you have inspected the contents and you have inspected the item mechanically and electrically.

Verify that you have received the following items within the package:

1. PDB4xx Balanced Amplified Photodetector
2. Adapter Plate with four M2x8 screws and a hex key 1.5, for post-mounting the unit on a optical table
3. Power supply ($\pm 12V$, 0.2A), switchable to 115V or 230V line voltage
4. Operation manual

2.2 Getting Started

Note

Prior to operation, please check, if the indicated line voltage range on the power supply matches with your local mains voltage! If you want use your own power supply, Thorlabs offers an appropriate power connector cable.

- Carefully unpack the unit and accessories. If any damage is noticed, do not use the unit. Contact [Thorlabs](#) and have us replace the defective unit.
- If required, mount the unit on your optical table or application. Therefore, mount the adapter plate on bottom or side wall using the four M2x8 screws first. The adapter plate has two mounting holes, M4 and #8-32. The M4 thread is marked. These threads can be used for mounting onto Thorlabs posts.
- If required, mount external optics, filters, apertures or fiber adapters.
- Set the power supply to your local mains voltage (115 or 230 VAC):

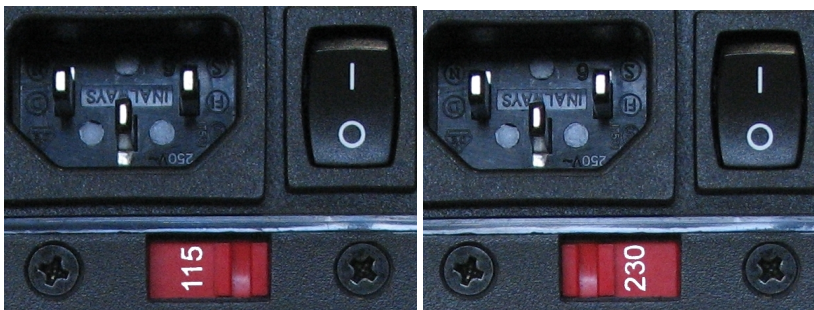

- Connect the DC output cable of the power supply to the POWER IN jack.
- Connect the power supply to the AC outlet, turn power supply on
- Connect RF OUTPUT with coaxial cable to the data acquisition device.
- If necessary, connect monitor outputs (MONITOR+, MONITOR-) to measure the optical input power for each channel individually.

3 Operating Instruction

- Turn the power switch of the power supply to I. The green LED next to the DC input connector indicates that the power supply is operating correctly.
- Connect the optical source(s) to the optical input(s). The FC adapter will accommodate multi-mode as well as single-mode fiber.

Attention

Be very careful about the force when connecting the fibers to the optical inputs! The photodiodes are mounted in such way, that the gap between the protective diode glass and the fiber tip is as small as possible. For this reason, **do not tighten** the fiber connector extremely in order to avoid damages to the glass window that protects the photodiode.

- For free-space beam applications, the FC adapters can be removed in order to have direct access to the photodetectors (not for PDB430C and PDB460C - see section "[Optical Inputs](#)" for details).
- The MONITOR outputs can be used to conveniently check the detected signal from each free space input beam. The maximum output voltage swing of the MONITOR outputs is 10V for high impedance loads (1.5 V into 50 Ω loads). Saturation of the MONITOR outputs will occur at optical input power greater than 1 mW.
- The RF output signal must not exceed the maximum RF OUTPUT voltage swing (see Technical Data) to avoid saturation.
- For balanced operation illuminate both photodetectors simultaneously and use either the RF OUTPUT or the MONITOR outputs to fine-tune the optical power balance by observing voltage on a digital voltmeter or other low-frequency measurement device.
- Do not exceed a maximum power density of 4 W/cm² for maximum linearity performance when measuring focused beams, fiber outputs, or small diameter beams.
- After finishing measurements, turn power off.

Note

To prevent saturation of the balanced amplifier make sure that the power difference between the optical inputs remains less than the saturation power level (see "RF OUT CW Saturation Power" in the Technical Data section).

Attention

The damage threshold of the photo diodes is 20 mW! Exceeding this value will permanently destroy the detector!

3.1 Operating Principle

Thorlabs PDB4xx Series Balanced Amplified Photodetectors consist of two well-matched photodiodes and an ultra-low noise, high-speed transimpedance amplifier that generates an output voltage (**RF OUTPUT**) proportional to the difference between the photo currents of the two photodiodes, i.e. the difference of between the two optical input signals.

Additionally, the unit has two monitor outputs (**MONITOR+** and **MONITOR-**) to observe the optical input power level on each photodiode separately. Due to their increased cut-off frequency, these outputs can also be used to measure low frequency modulated signals on each detector separately.

The PDB4xx Series is powered by an external linear power supply (± 12 V, 200 mA - included) via a PICO M8 power connector.

Below is a functional block diagram of the PDB4xx Series Balanced Amplified Photodetectors:

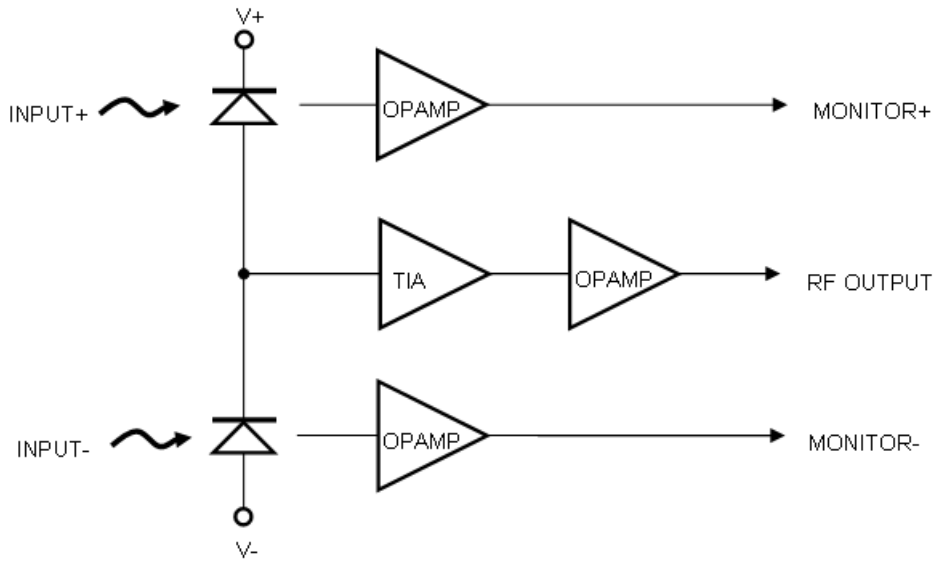

3.2 Optical Inputs

For all models except PDB430C and PDB460C, the fiber inputs are coupled to the photodiodes using two removable FC adapters. These FC receptacles accommodate either single-mode or multi-mode fiber with FC/PC or FC/APC connectors as well. PDB430C and PDB460C have also FC adapters, but they are **not removable**.

Attention

Be very careful about the force when connecting the fibers to the optical inputs! The photodiodes are mounted in such way, that the gap between the protective diode glass and the fiber tip is as small as possible. For this reason, **do not tighten** the fiber connector extremely in order to avoid damages to the glass window that protects the photodiode.

For all **PDB4xxC** models the FC adapters are aligned for Corning SMF28™ single mode fiber with PC connectors. When using FC/APC connectors, minimal alignment errors may occur due to the small detector size, which will result in a reduced output signal. In such case, FC receptacle can be rotated from its original position in steps of 90° to check for an improved alignment. For this process use an optical input power below the saturation level while observing RF OUTPUT voltage on a digital voltmeter or other low-frequency measurement device. If you have an AC-coupled version, use either MONITOR output (CW signal) or RF OUTPUT (modulated optical signal) with connected oscilloscope for measurement.

In general, multi-mode fiber at the input can be used, but in this case the light beam spot diameter exceeds detector's active area, which results in a reduced output signal as well.

For free-space beam applications it is recommended to remove FC adapter (receptacle) to have direct access to the photodiodes as shown below:

**Note**

FC adapters (receptacles) are **not** removable from PDB430C and PDB460C enclosures!

Note

Do not exceed a maximum power density of 4 W/cm^2 for maximum linearity performance when measuring focused or small diameter beams. Always try to illuminate the whole detector active area to prevent nonlinearities. Equal power densities on both detectors are important for maximum common mode noise suppression (CMRR).

The PDB4xx Series can be used in balanced mode (both inputs are illuminated) as well as in single detector mode. In single detector mode, the RF OUTPUT swing depends on which INPUT is used: it is positive for INPUT+ and negative for INPUT-.

In single detector mode, the optical input power should be below the specified CW saturation power (see [Technical Data](#)¹⁵⁾) to avoid saturation of the RF OUTPUT amplifier.

In balanced mode the power difference between the optical inputs should be less than the CW Saturation Power. If necessary, use external neutral density filters or attenuators to reduce the input light level.

Attention

The optical damage threshold is 20 mW. Exceeding this value will permanently damage the photodiodes!

3.3 Electrical Outputs

The Thorlabs PDB4xx Series has three SMA output connectors:

- **MONITOR +**
- **MONITOR -**
- **RF OUTPUT**

RF OUTPUT delivers an output voltage proportional to the difference between the photo currents of the two photodiodes. This voltage can be calculated to:

$$U_{RF,OUT} = (P_{opt,1} - P_{opt,2}) \times \mathcal{R}(\lambda) \times G$$

with: $\mathcal{R}(\lambda)$ - responsivity of the photo diode at given wavelength

$P_{opt,1}$ and $P_{opt,2}$ - optical input power

G - transimpedance gain of the RF output

The responsivity $\mathcal{R}(\lambda)$ for a given wavelength can be read from the individual curves in section Technical Data to estimate the **RF OUTPUT** voltage. Please note that the given responsivity curves represent typical values - individual responsivity may deviate.

The maximum output voltage swing of the **RF OUTPUT** can be found in the [Technical Data](#) ¹⁵ section.

The optical input saturation power (see the PDB4xx Series individual technical data in the appendix) of the balanced detector is the minimum value, as it is given for the wavelength with the detector highest responsivity. At other wavelengths, saturation will be reached at higher input power levels. The output signal should not exceed the maximum output voltage to avoid saturation. Therefore the optical input power (or the power difference between the optical inputs) should not exceed CW Saturation Power listed in Specifications.

MONITOR Outputs

The signal monitor outputs (**MONITOR+** and **MONITOR-**) allow to observe the input power level and can be used as individual power indicators. These outputs can also be used to measure low frequency modulated signals on each detector separately. The maximum output voltage swing of the **MONITOR** output is +10 V for high impedance loads (+1.5 V into 50 Ω). Saturation of **MONITOR** outputs will occur at optical input power level greater than 1 mW, depending on the detector's wavelength response.

MONITOR outputs can be used to roughly adjust equal input power levels on each detector for balanced operation. While the DC component of the **RF OUTPUT** in balanced mode is zero, the **MONITOR** outputs provide capability to independently observe the individual optical input power. **MONITOR** outputs of the unit are also convenient to use for free-space beam alignment.

The amplifier offset voltage is factory set to zero at 23°C ambient temperature. A small drift during a short warm-up period (~5min) may occur. For exact DC light level measurements a constant temperature environment is recommended.

3.4 Mounting

The PDB4xx Series is housed in a rugged shielded aluminum enclosure.

For post mounting an adapter can be attached to the bottom or side surface using four M2x8 screws (see below). This adapter supports #8-32 as well as M4 post mounts. The M4 tread is marked.

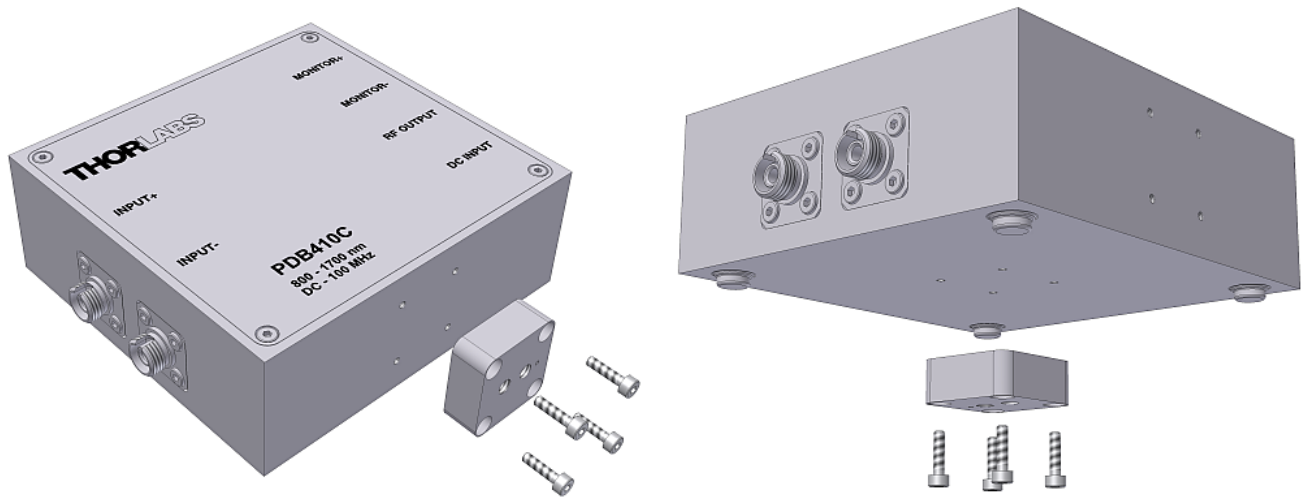

3.5 AC Coupling of the Outputs

Beside the standard DC coupling of the **RF OUTPUT**, AC coupled versions for any model of PDB4xx Series are available on request. AC coupling blocks the CW component (the unmodulated part) of the optical input signal. However, large CW components of the optical input signal will decrease linearity of the detectors.

AC coupling helps to improve the measurement capabilities in applications, where a comparably weak frequency modulated signal shall be measured on a strong CW background signal, which could saturate the amplifier. With AC coupling, equalizing of CW power levels on both inputs is not mandatory for noise cancellation. However, for optimal noise suppression the signal of interest (e.g. the modulated part) should be well balanced. AC coupling is also recommended when using the balanced detector in combination with a chopper and lock-in amplifier to further decrease noise level.

The lower cut-off frequency of the AC coupled versions is typically below 5 Hz.

Please note, that AC coupling slightly increases noise figures at lower frequencies. The measurement bandwidth of the RF OUTPUT is not affected by AC coupling.

The figure below shows the comparison of AC and DC coupled RF Output signals when modulating the input signal with a mechanical chopper at a frequency of 500 Hz.

Note: Input signal for AC coupling was increased by factor 2 to allow direct waveform comparison

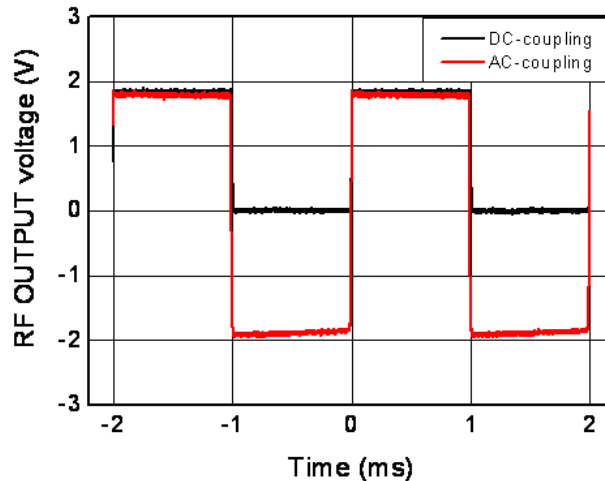

3.6 CMRR and Frequency Response

An important specification for balanced amplifiers is the Common Mode Rejection Ratio (CMRR) that reflects the ability to suppress common mode noise.

In the setup as described below, the Device under Test (DuT) - here a PDB4xx Series balanced detector - is tested for CMRR. A common mode signal is generated, which is canceled out when the amplifier is in balanced mode.

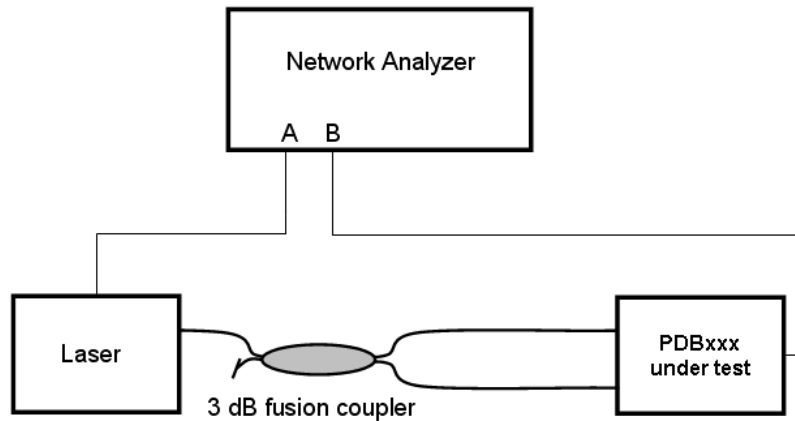

A network analyzer is used as signal generator (output A) and receiver (input B). The receiver is synchronized with the signal generator and measures selectively at the same frequency. A laser light source is modulated by the signal generator (port A) and acts as transmitter. To the laser output a 3 dB fusion coupler is connected, splitting the modulated light signal into two paths. Depending on the measurement task, one or both coupler outputs are connected to the inputs of the DuT, for example using S120-FC adapters. One of the DuT's outputs is connected to the network analyzer's Port B.

Frequency response measurements

The frequency response of each signal path can be measured by connecting only one coupler output to the appropriate input. This way, the frequency response curves of the RF OUTPUT from INPUT + and INPUT- can be measured, as well as the frequency responses of the MONITOR outputs, as shown in the individual technical data.

CMRR measurement

For Common Mode Rejection measurement, both outputs of the fusion coupler are connected to both inputs of the DuT. The optical power level at both inputs must be well matched ("balanced") in order to achieve the optimal common mode suppression. Now the common mode rejection can be measured as a function of frequency. The frequency response of the RF OUTPUT must be considered when calculating the CMRR - it is the difference between the RF OUTPUT signal at a given frequency and the measured common mode or balanced output signal - at the same frequency. Typical measurement curves can be found in the individual technical data.

3.7 Recommendations

Thorlabs PDB4xx Series Balanced Amplified Photodetectors can eliminate noise sources to allow precise measurements. The PDB4xx Series is designed to be used in a dual beam setup: one optical path for measurement and one invariant reference path. If set up properly, the PDB4xx Series can reduce common mode noise for more than 35 dB over the specified frequency range. Below are given some recommendations to achieve an optimal common mode suppression:

- To obtain the maximum possible common mode rejection (common mode noise suppression), equal power levels on each photodetector are essential. Any power imbalance will be amplified and hence decrease the possible noise reduction
- Equal power densities on both detectors are important as well to obtain maximum possible common mode rejection. Always try to illuminate the whole active area of the detectors to prevent nonlinearities. Focused high power beams may lead to frequency response degradation, resulting in dramatically reduced common mode rejection.
- Equal optical path lengths are very important for common mode noise suppression especially at higher frequencies. Any path length difference will introduce a phase difference between the two signals, which will decrease the noise reduction capability of the balanced detector. The figure on next page shows the maximum allowed path length difference in air to obtain a desired CMRR. For fiber based application the maximum path length difference must be divided by 1.5.

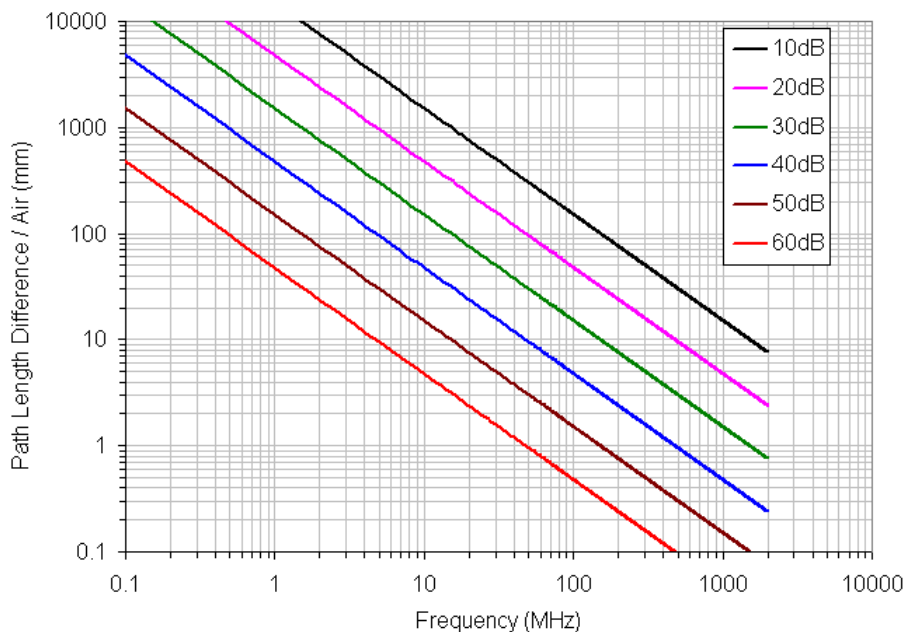

- Avoid etalon effects (interference fringes caused between two optical surfaces) in optical paths. Using angle polished optical connectors will greatly reduce etalon effects in a fiber based setup. Effects like residual frequency modulation, polarization noise, polarization wobble or spatial modulation can also degrade common mode noise suppression. For further details contact Thorlabs. In general, reducing sources of differential losses in the optical paths (other than the measurement itself) will improve the common mode noise reduction.
- Another critical point can be electrostatic coupling of electrical noise associated with ground loops. In most cases an electrically isolated post (see Thorlabs parts TRE or TRE/M) will suppress electrical noise coupling. Always try to identify the electrical noise sources and increase the distance to the PDB4xx Series Balanced Detector. Different common ground points can also be tested.

4 Maintenance and Service

Protect the PDB4xx Series from adverse weather conditions. The PDB4xx Series is not water resistant.

Attention

Be very careful about the force when connecting the fibers to the optical inputs! The photodiodes are mounted in such way, that the gap between the protective diode glass and the fiber tip is as small as possible. For this reason, do not tighten the fiber connector extremely in order to avoid damages to the glass window that protects the photodiode.

Attention

To avoid damage to the instrument, do not expose it to spray, liquids or solvents!

The unit does not need a regular maintenance by the user. It does not contain any modules and/or components that could be repaired by the user himself. If a malfunction occurs, please contact [Thorlabs](#) for return instructions.

Do not remove covers!

To clean the PDB4xx Series series housing, use a mild detergent and damp cloth. Do not soak the unit in water or use solvent based cleaners.

When cleaning the windows of the photodetectors, please remember that is a sensitive optical device. Gently blow off any debris using compressed air and wipe gently with an optic tissue wetted with isopropanol or alcohol.

5 Appendix

Comments and explanations to the individual specifications

- **Typical max. responsivity** is the peak responsivity $\mathfrak{R}(\lambda)_{\max}$ of the photo diode.
- **Transimpedance and conversion gain [V/A]** is the ratio of output voltage to photo current, it is wavelength independent. Values to RF output are always given into a high impedance load. For 50 Ω loads these values are divided by two.
- **Conversion gain [V/W]** is the ratio of output voltage to input optical power, by other words

$$G_{CONV} = G_{TRANS} \times \mathfrak{R}(\lambda)$$

This formula shows, that the conversion gain is dependent on the actual wavelength. In specifications, it is given only for the peak responsivity wavelength of the photo diode. Values to RF output are always given into a high impedance load. For 50 Ω loads these values are divided by two.

- **NEP** (Noise Equivalent Power) is commonly stated for DC to 10 MHz frequency range, this is a usual criteria for balanced detectors. If different, the frequency range is stated individually.
- **Integrated noise** is always given from DC to the actual detector's bandwidth, measured as RMS power into a 50 Ω load.
- **Overall output noise voltage** [V_{RMS}] is the value which can be measured across a 50 Ω load at large bandwidth, e.g., if connect the RF output to a 50 Ω terminated scope input.
- **Max. input power** is the damage threshold of the photo diode.
- **Typical noise spectra** (diagrams): These spectra were measured using an electrical spectrum analyzer (resolution bandwidth 100 kHz, video bandwidth 10 kHz unless otherwise noted). The INPUTs of the balanced detectors under test were blocked. The lower curve in the diagram was measured with the same setup and the balanced detectors under test switched off, i.e., it represents the measurement system's noise floor.
- **Monitor outputs** are designed for use with high impedance loads (e.g., high-Z scope input etc.), but can also drive 50 Ω loads. Monitor outputs conversion gain is 10 V/mW, given at the detectors peak responsivity and high impedance load.
- **Typical frequency response curves** are measured using the setup described in section ["CMRR and Frequency Response"](#)^[11]

5.1 Technical Data

Common	
Optical Inputs	FC, removable (except PDB430C and PDB460C: NOT removable)
Max. Input Power (Damage Threshold)	20 mW
Electrical Outputs	SMA
RF OUTPUT	
Impedance	50 Ω
Voltage Swing, max. (PDB410 / 420 / 430 / 440 / 460)	± 3.6 V ¹⁾
Voltage Swing, max. PDB450, gain - 103 to 106 PDB450, gain - 107	± 4.6 V ¹⁾ ± 10 V ¹⁾
DC Offset	$< \pm 3$ mV
MONITOR Outputs	
Impedance	220 Ω
Voltage Swing, max.	10 V (high impedance load) 1.55 V (50 Ω load)
Bandwidth	DC to 1 MHz
Conversion Gain	10 V/mW @ peak responsivity
Voltage Noise	< 180 μ V _{RMS}
DC Offset	$< \pm 2$ mV
General	
Power Supply	± 12 V, 200mA
Dimensions	85 x 80x 30 mm ³
Operating Temperature Range ²⁾	0 - 40 °C
Storage Temperature Range	-40 to 70 °C
Weight	0.35 kg (w/o power supply)

¹⁾ Values are given for high impedance load. For a 50 Ω load, values to be divided by 2.

²⁾ non-condensing

Typical Detector responsivity curves

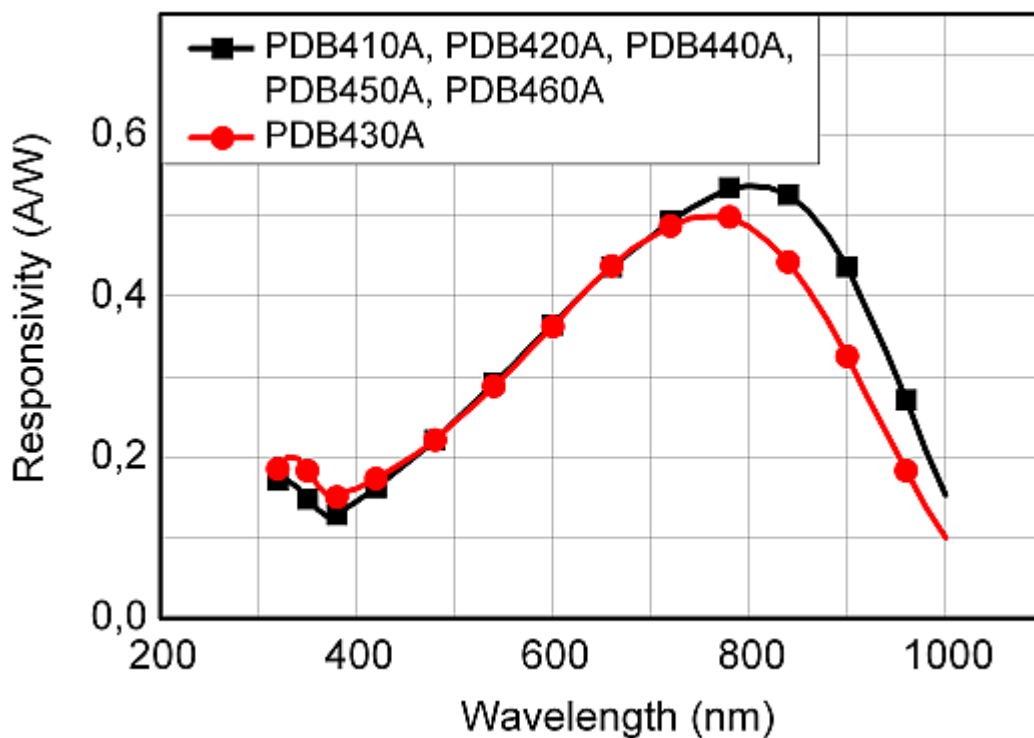

Typical InGaAs Detector responsivity (PDA4xxA)

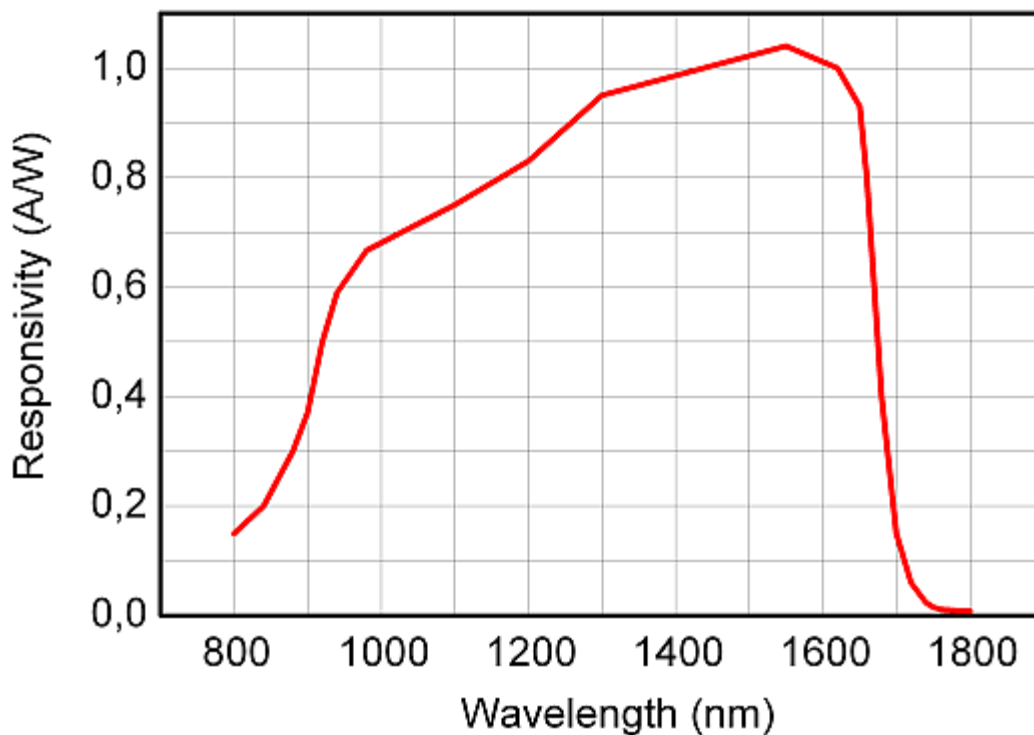

Typical Si Detector responsivity (PDA4xxC)

Typical Monitor Output Frequency Response

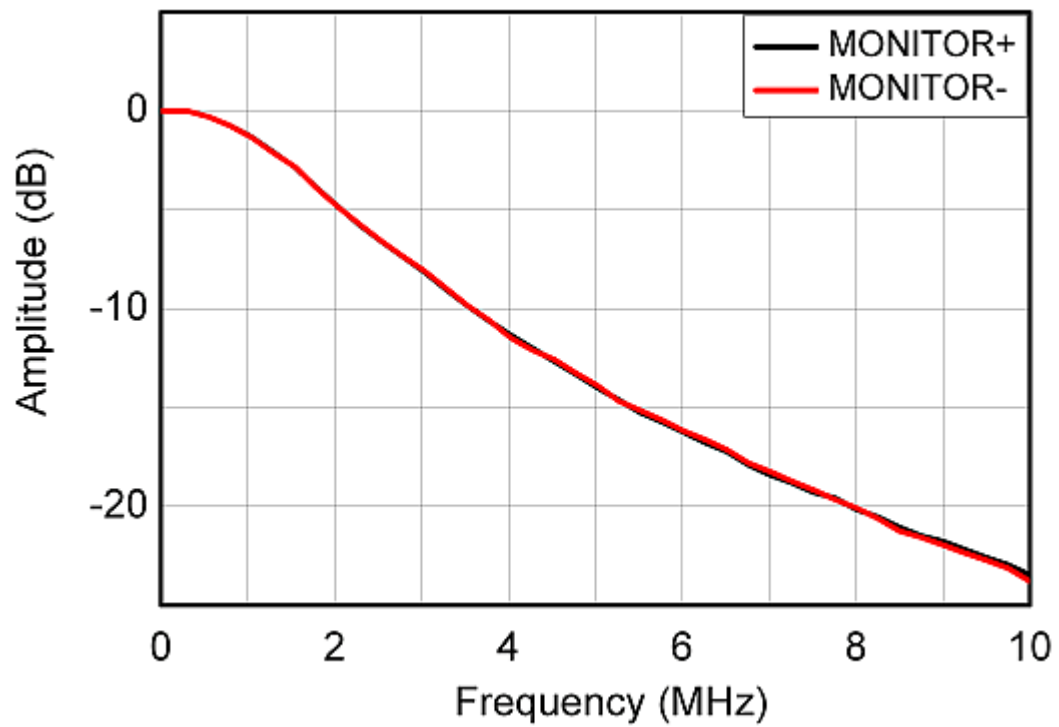

PDB4xx Series Monitor Output Frequency Response

5.1.1 PDB410x Individual Technical Data

	PDB410A	PDB410C
Detector Material / Type	Si / PIN	InGaAs / PIN
Operating Wavelength Range	320 - 1000 nm	800 - 1700 nm
Max. Responsivity, typ.	0.53 A/W	1.0 A/W
Detector Active Area Ø	0.8 mm	0.3 mm
RF OUTPUT Bandwidth (-3 dB)	DC - 100 MHz	
CMRR	>25 dB (typ. >35 dB)	
RF OUTPUT Transimpedance Gain ¹⁾	50×10^3 V/A	
RF OUTPUT Conversion Gain ²⁾	26.5×10^3 V/W	50×10^3 V/W
CW Saturation Power	135 μ W @ 820 nm	72 μ W @ 1550 nm
Minimum NEP (DC to 10 MHz)	7 pW/ $\sqrt{\text{Hz}}$	3.8 pW/ $\sqrt{\text{Hz}}$
Integrated Noise (DC to 100 MHz)	100 nW _{RMS}	65 nW _{RMS}
Overall Output Voltage Noise	2 mV _{RMS}	2.2 mV _{RMS}

¹⁾ Values are given for high impedance load. For a 50 Ω load, values to be divided by 2.

²⁾ Values are given at peak responsivity of the detector, for high impedance load. For a 50 Ω load, values to be divided by 2.

PDB410A

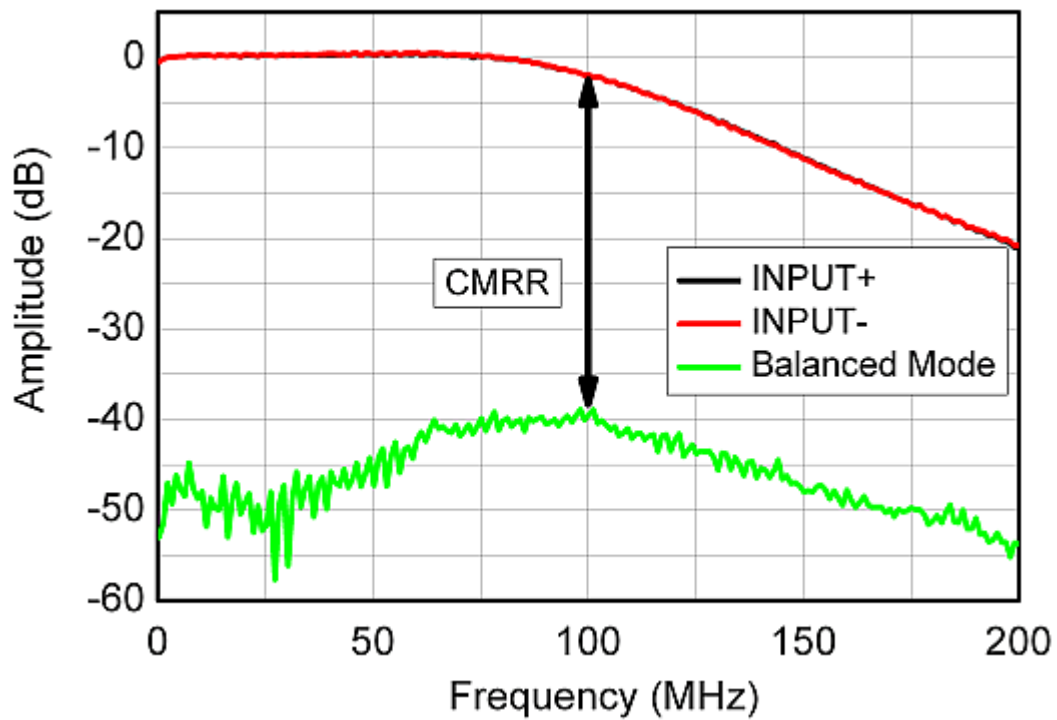
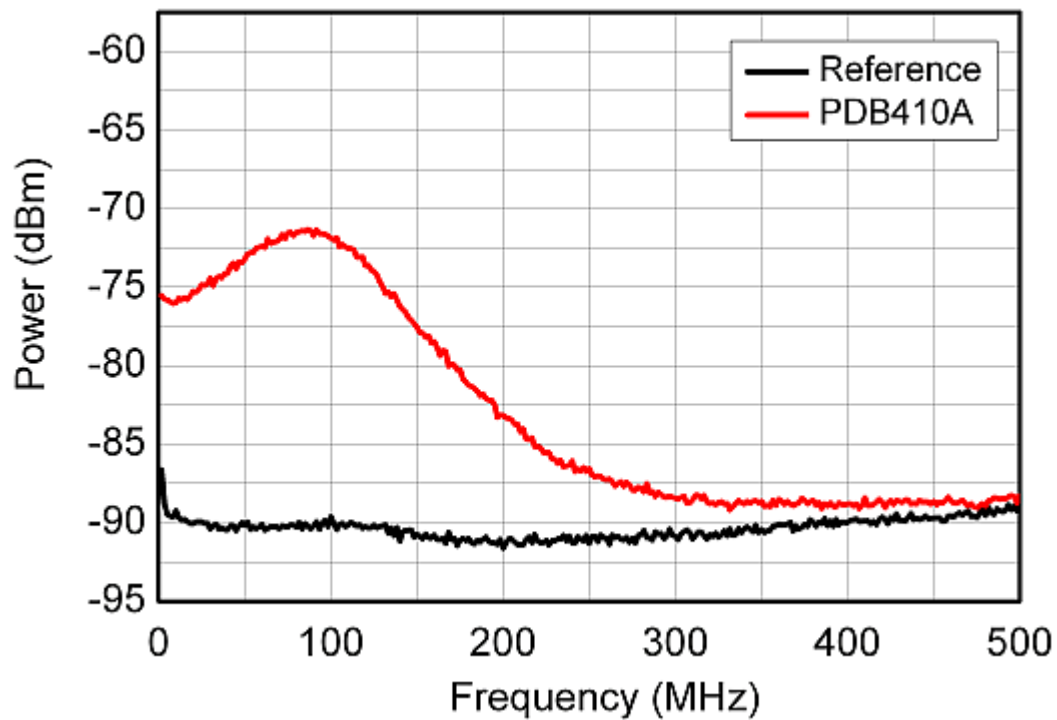
*PDB410A: Typical RF OUTPUT Frequency Response**PDB410A: RF OUTPUT Spectral Noise*

PDB410C

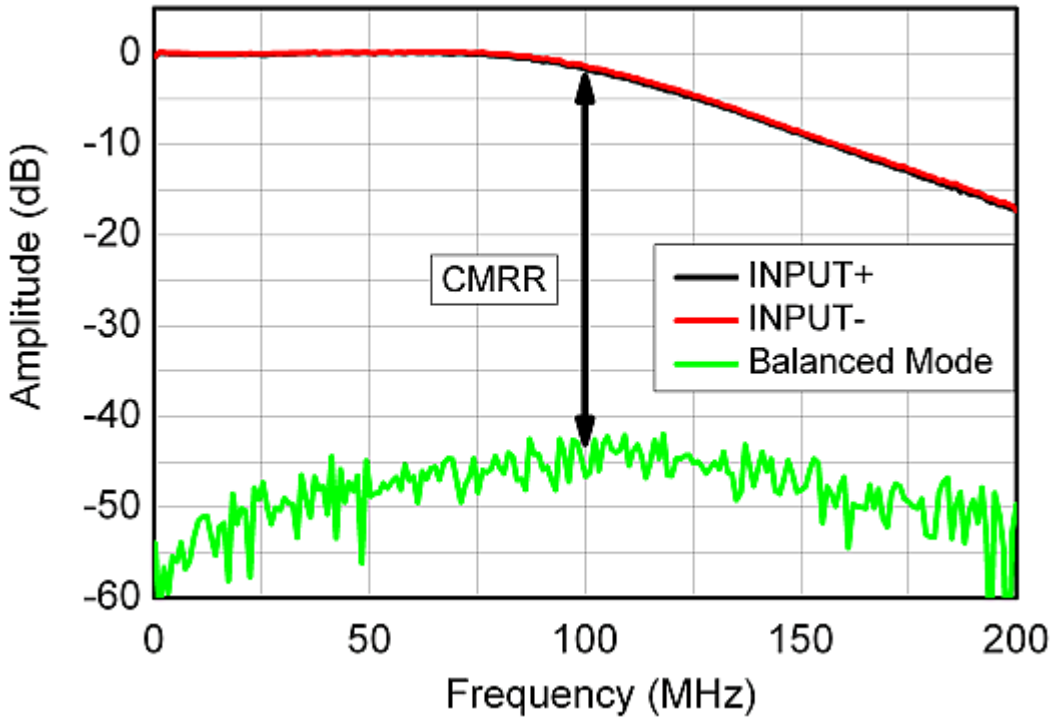

PDB410C: Typical RF OUTPUT Frequency Response

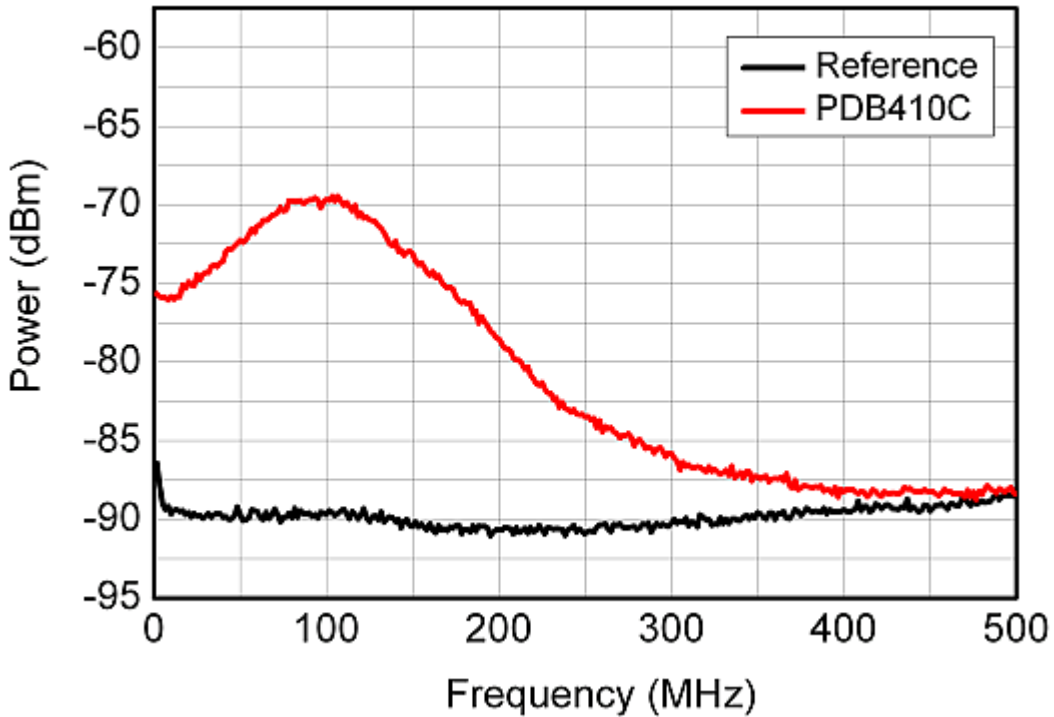

PDB410C: RF OUTPUT Spectral Noise

5.1.2 PDB420x Individual Technical Data

	PDB420A	PDB420C
Detector Material / Type	Si / PIN	InGaAs / PIN
Operating Wavelength Range	320 - 1000 nm	800 - 1700 nm
Max. Responsivity, typ.	0.53 A/W	1.0 A/W
Detector Active Area Ø	0.8 mm	0.3 mm
RF OUTPUT Bandwidth (-3 dB)	DC - 75 MHz	
CMRR	>35 dB	
RF OUTPUT Transimpedance Gain ¹⁾	250×10^3 V/A	
RF OUTPUT Conversion Gain ²⁾	133×10^3 V/W	250×10^3 V/W
CW Saturation Power	27 μ W @ 820 nm	15 μ W @ 1550 nm
Minimum NEP (DC to 10 MHz)	6.5 pW/ $\sqrt{\text{Hz}}$	3.5 pW/ $\sqrt{\text{Hz}}$
Integrated Noise (DC to 100 MHz)	77 nW _{RMS}	47 nW _{RMS}
Overall Output Voltage Noise	7 mV _{RMS}	7.7 mV _{RMS}

¹⁾ Values are given for high impedance load. For a 50 Ω load, values to be divided by 2.

²⁾ Values are given at peak responsivity of the detector, for high impedance load. For a 50 Ω load, values to be divided by 2.

PDB420A

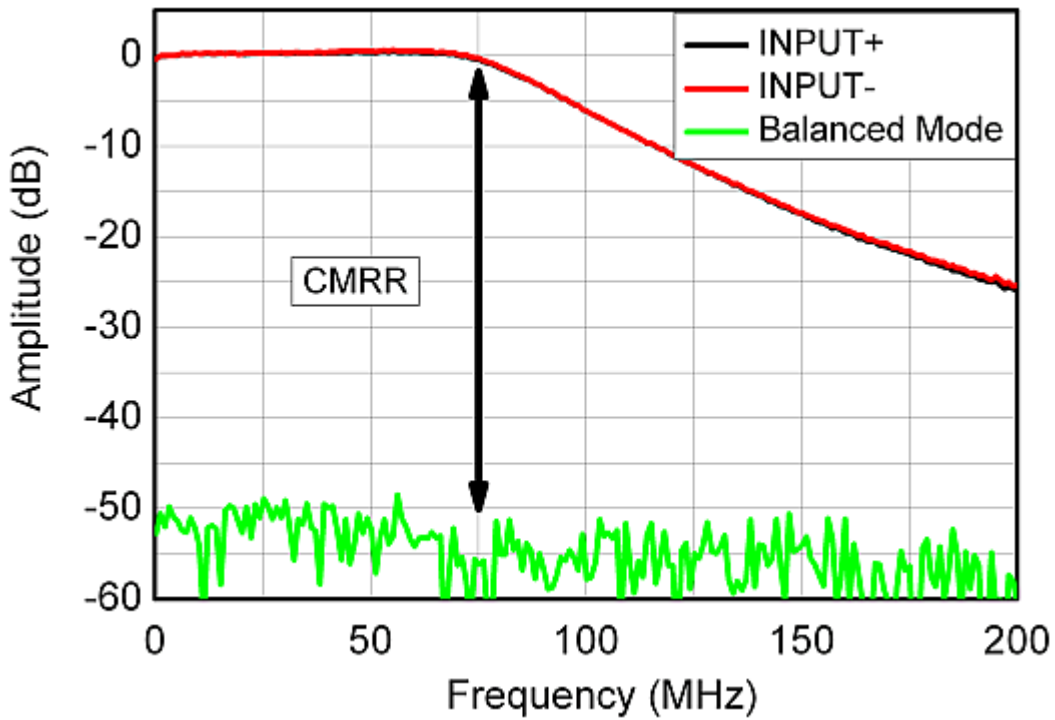

PDB420A: Typical RF OUTPUT Frequency Response

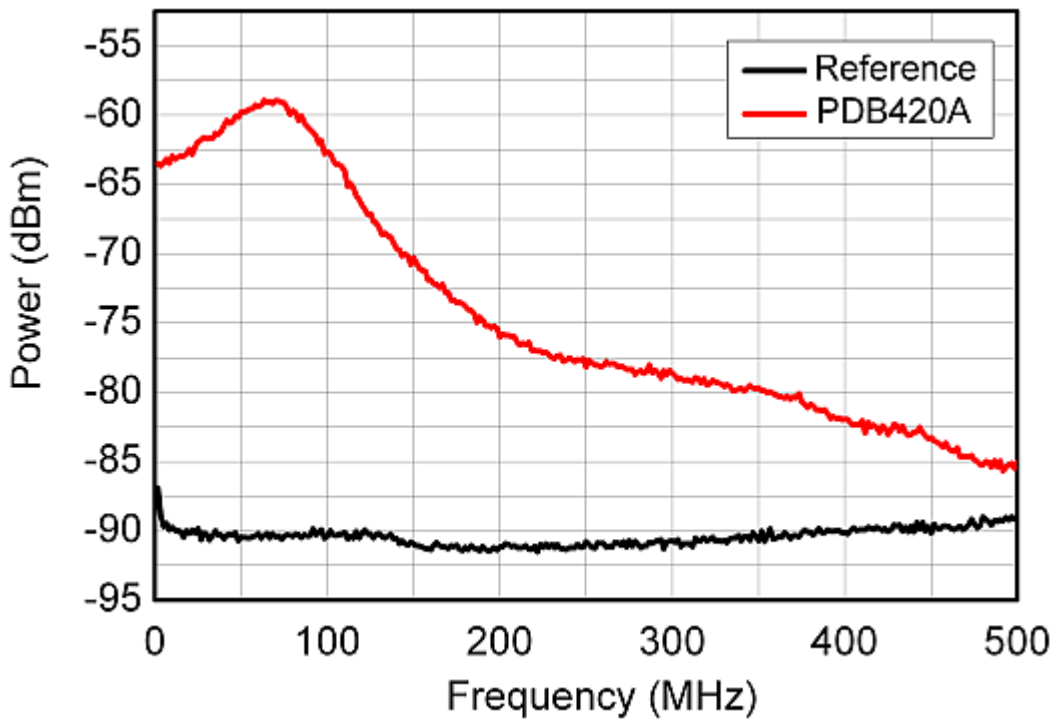

PDB420A: RF OUTPUT Spectral Noise

PDB420C

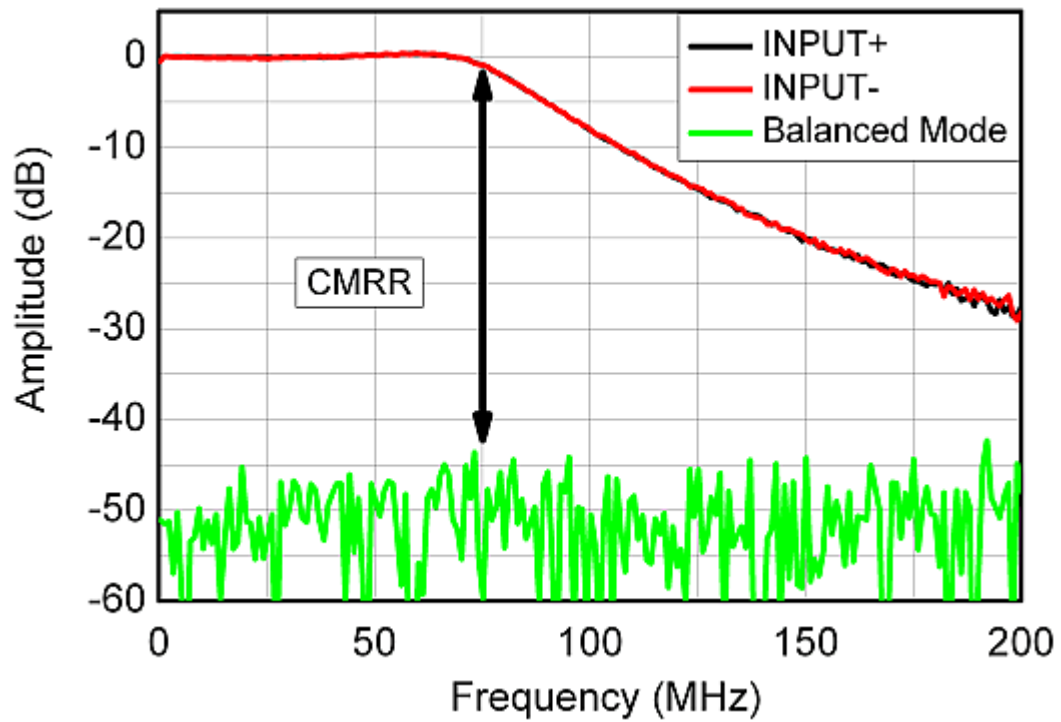
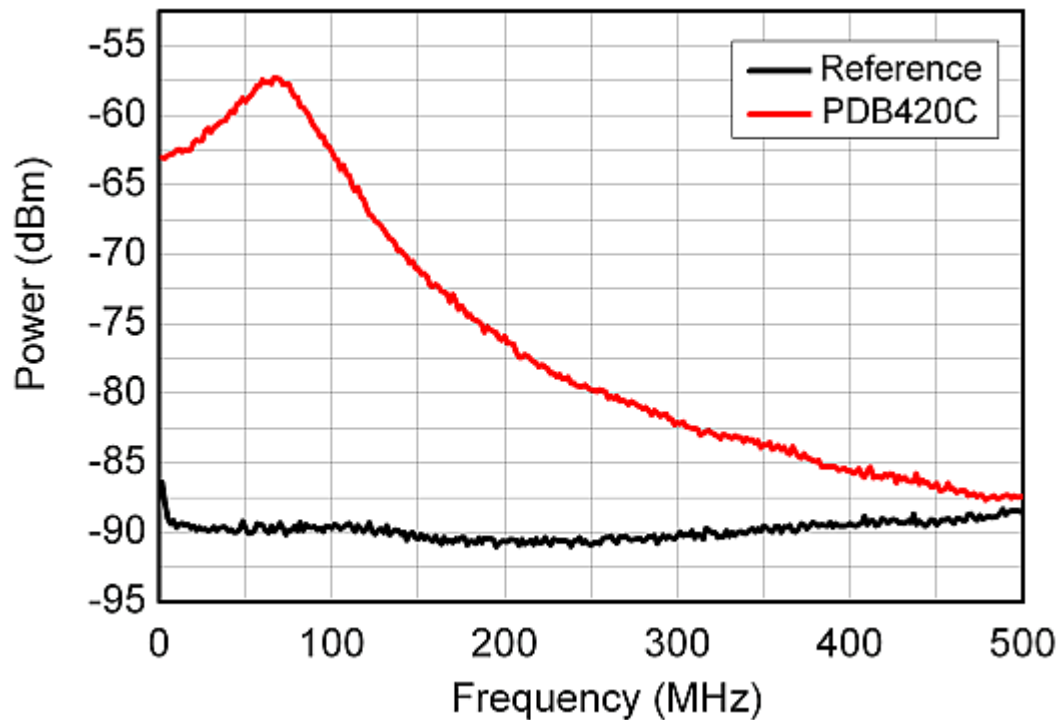
*PDB420C: Typical RF OUTPUT Frequency Response**PDB420C: RF OUTPUT Spectral Noise*

5.1.3 PDB430x Individual Technical Data

	PDB430A	PDB430C
Detector Material / Type	Si / PIN	InGaAs / PIN
Operating Wavelength Range	320 - 1000 nm	800 - 1700 nm
Max. Responsivity, typ.	0.5 A/W	1.0 A/W
Detector Active Area Ø	0.4 mm	0.15 mm
RF OUTPUT Bandwidth (-3 dB)	DC - 350 MHz	
CMRR	>20 dB (typ. >25 dB)	
RF OUTPUT Transimpedance Gain ¹⁾	10×10^3 V/A	
RF OUTPUT Conversion Gain ²⁾	5×10^3 V/W	10×10^3 V/W
CW Saturation Power	720 μ W @ 820 nm	360 μ W @ 1550 nm
Minimum NEP (DC to 100 MHz)	13.5 pW/ \sqrt Hz	7 pW/ \sqrt Hz
Integrated Noise (DC to 100 MHz)	505 nW _{RMS}	256 nW _{RMS}
Overall Output Voltage Noise	1.4 mV _{RMS}	1 mV _{RMS}

Attention PDB430C: FC receptacles are not removable!

¹⁾ Values are given for high impedance load. For a 50 Ω load, values to be divided by 2.

²⁾ Values are given at peak responsivity of the detector, for high impedance load. For a 50 Ω load, values to be divided by 2.

PDB430A

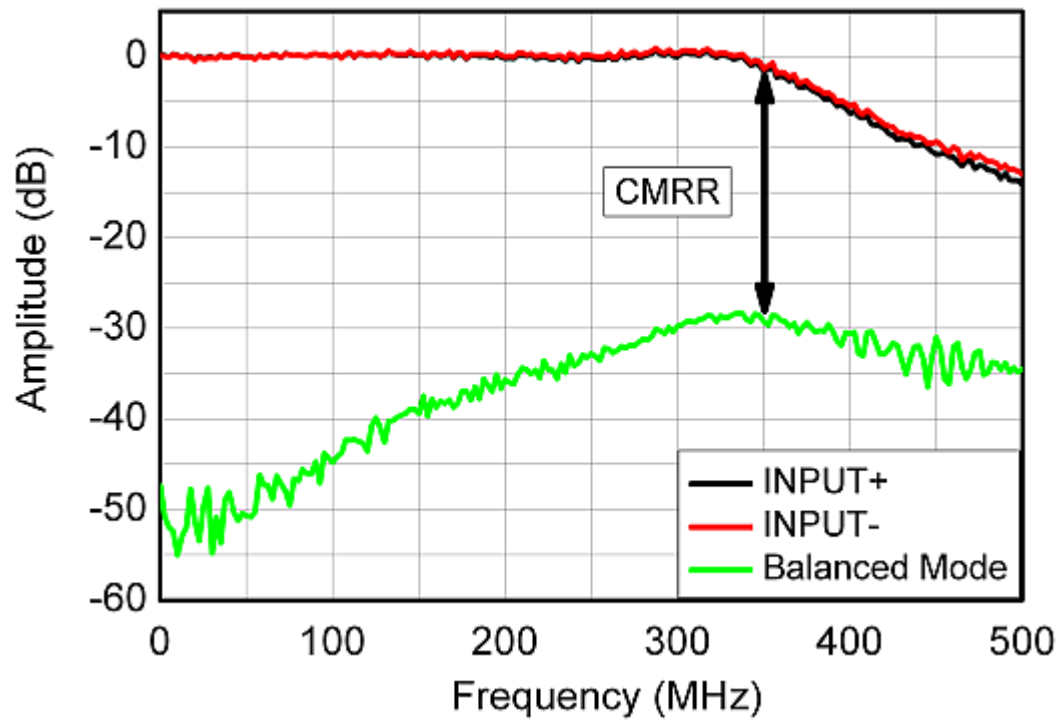
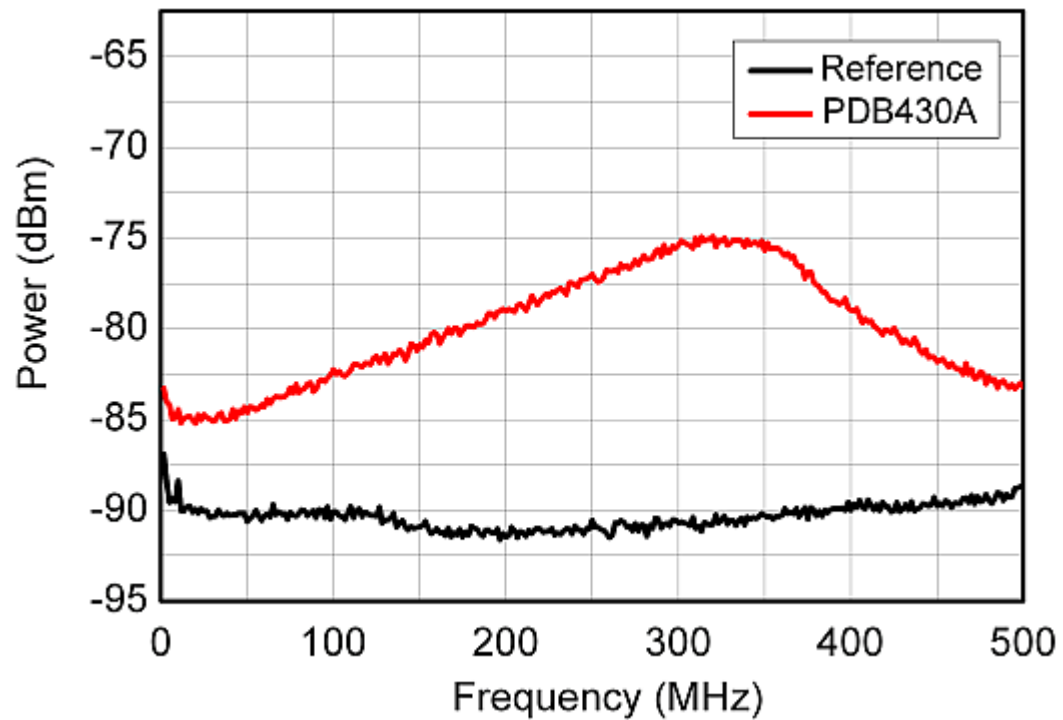
*PDB430A: Typical RF OUTPUT Frequency Response**PDB430A: RF OUTPUT Spectral Noise*

PDB430C

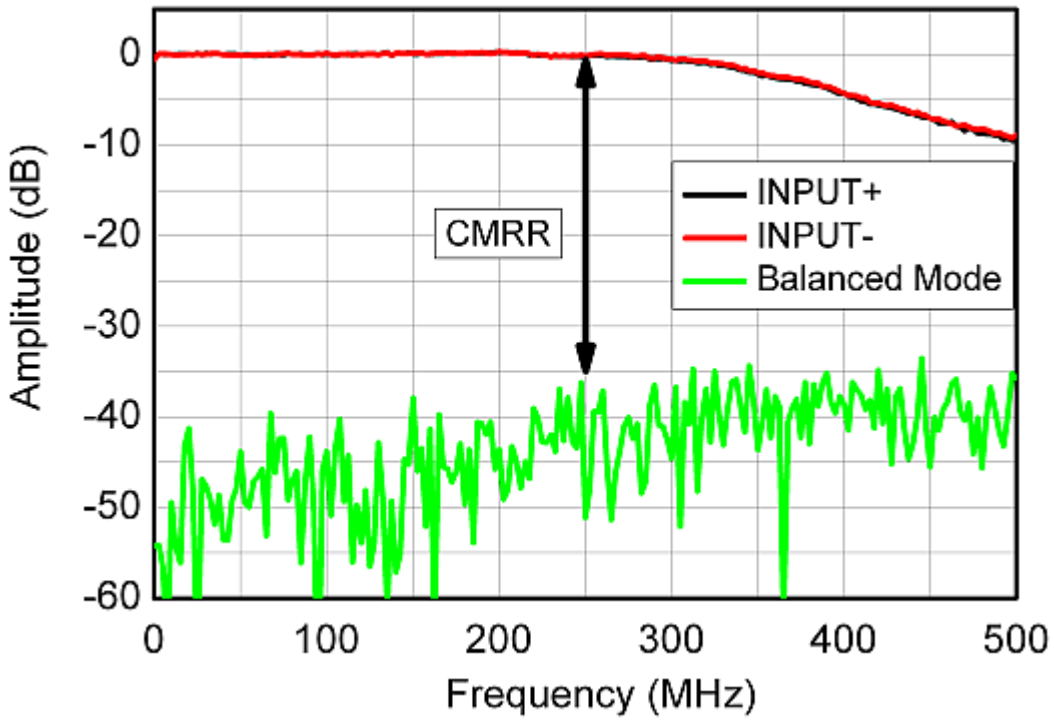

PDB430C: Typical RF OUTPUT Frequency Response

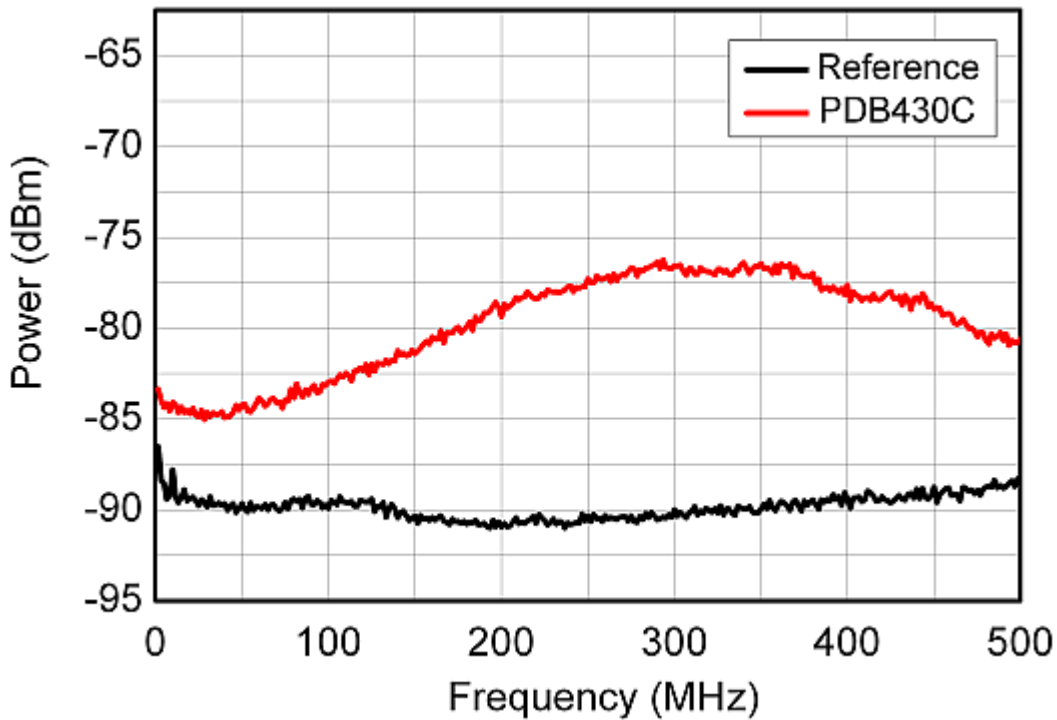

PDB430C: RF OUTPUT Spectral Noise

5.1.4 PDB440x Individual Technical Data

	PDB440A	PDB440C
Detector Material / Type	Si / PIN	InGaAs / PIN
Operating Wavelength Range	320 - 1000 nm	800 - 1700 nm
Max. Responsivity, typ.	0.53 A/W	1.0 A/W
Detector Active Area Ø	0.8 mm	0.3 mm
RF OUTPUT Bandwidth (-3 dB)	DC - 15 MHz	
CMRR	>35 dB	
RF OUTPUT Transimpedance Gain ¹⁾	51×10^3 V/A	
RF OUTPUT Conversion Gain ²⁾	27×10^3 V/W	51×10^3 V/W
CW Saturation Power	130 μ W @ 820 nm	70 μ W @ 1550 nm
Minimum NEP (DC to 10 MHz)	6.4 pW/ $\sqrt{\text{Hz}}$	3.3 pW/ $\sqrt{\text{Hz}}$
Integrated Noise (DC to 100 MHz)	25 nW _{RMS}	14 nW _{RMS}
Overall Output Voltage Noise	0.4 mV _{RMS}	0.4 mV _{RMS}

¹⁾ Values are given for high impedance load. For a 50 Ω load, values to be divided by 2.

²⁾ Values are given at peak responsivity of the detector, for high impedance load. For a 50 Ω load, values to be divided by 2.

PDB440A

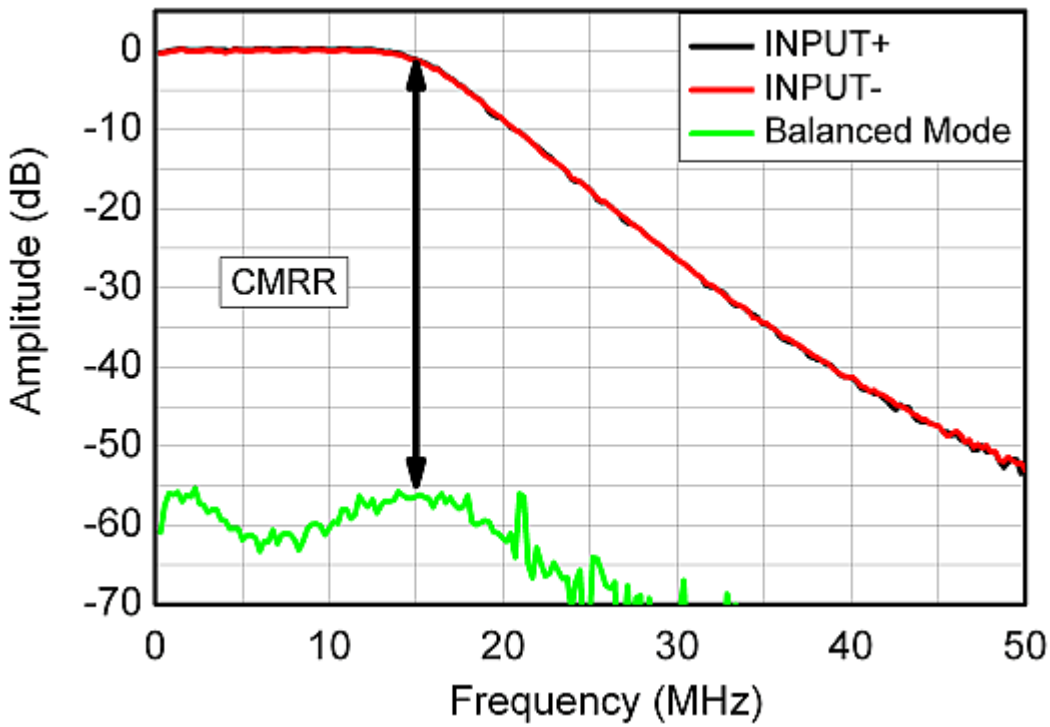

PDB440A: Typical RF OUTPUT Frequency Response

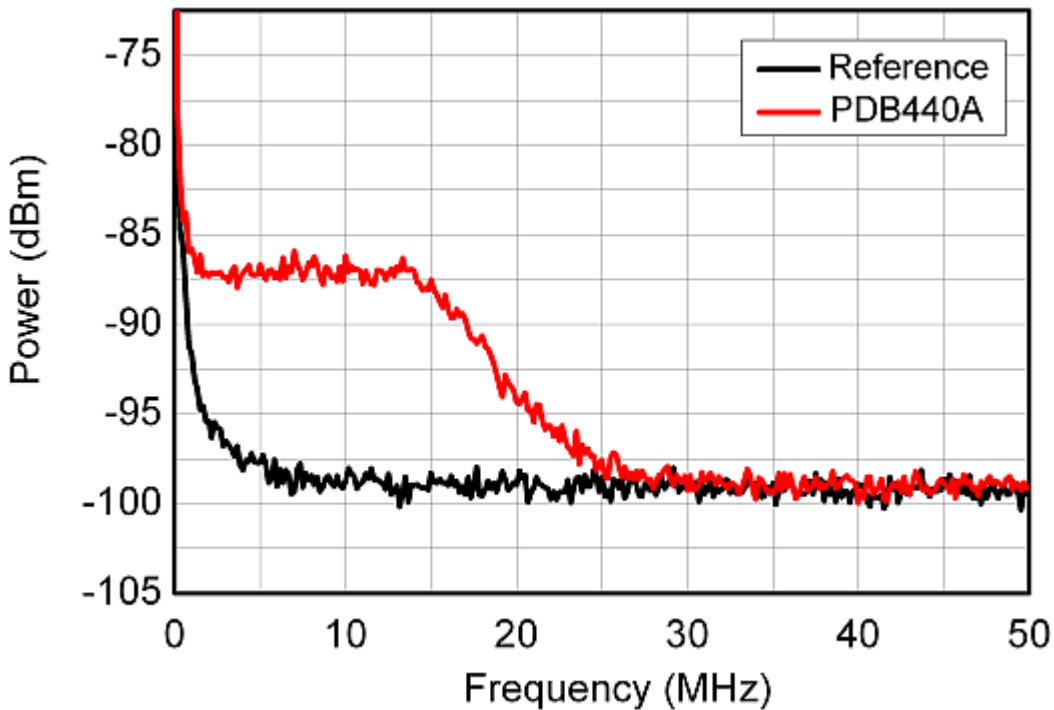

PDB440A: RF OUTPUT Spectral Noise

PDB440C

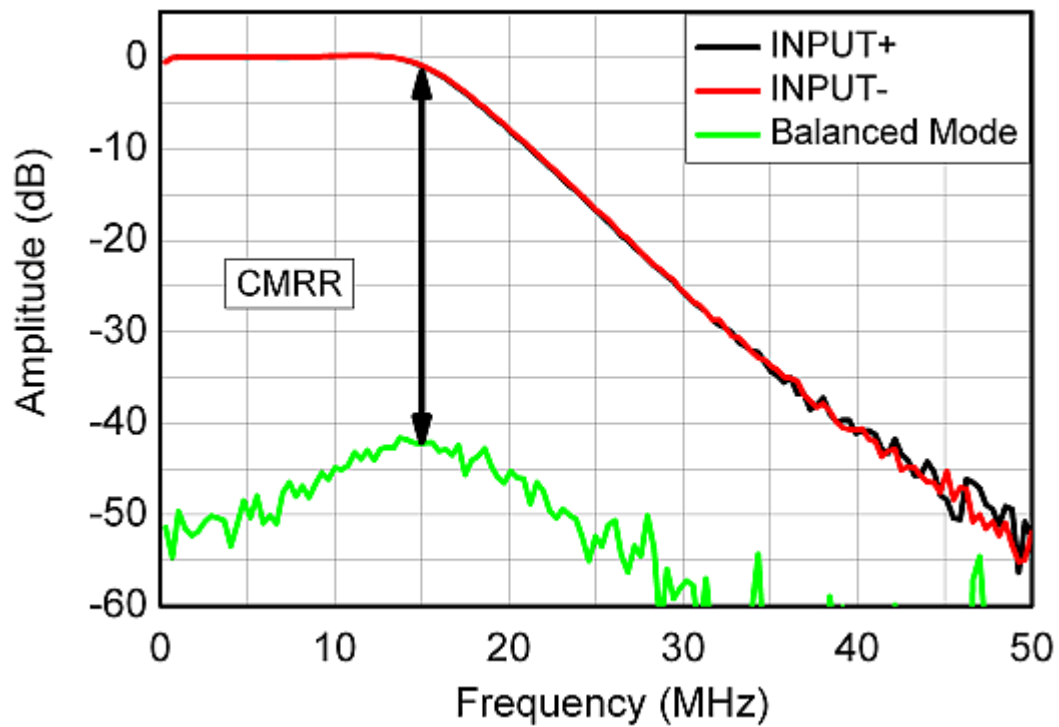

PDB440C: Typical RF OUTPUT Frequency Response

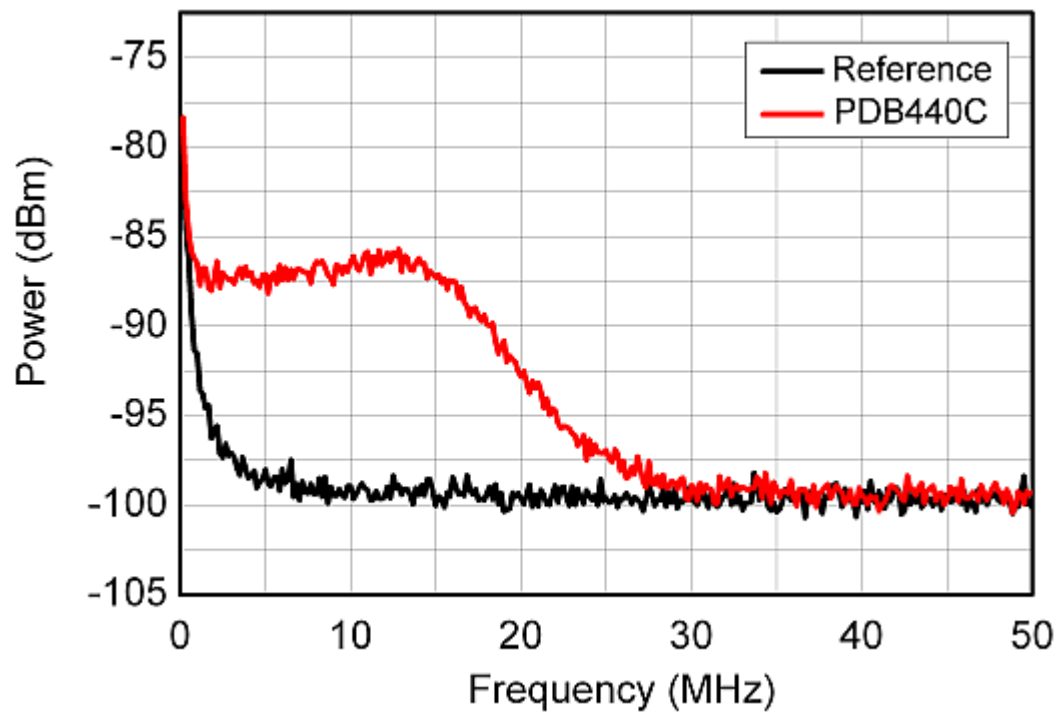

PDB440C: RF OUTPUT Spectral Noise

5.1.5 PDB450x Individual Technical Data

	PDB450A	PDB450C
Detector Material / Type	Si / PIN	InGaAs / PIN
Operating Wavelength Range	320 - 1000 nm	800 - 1700 nm
Max. Responsivity, typ.	0.53 A/W	1.0 A/W
Detector Active Area Ø	0.8 mm	0.3 mm
RF OUTPUT Bandwidth (-3 dB)	DC - 150 / 45 / 4 / 0.3 / 0.1 MHz	
CMRR	>25 dB (typ. >30 dB)	
RF OUTPUT Transimpedance Gain ¹⁾	10 ³ / 10 ⁴ / 10 ⁵ / 10 ⁶ / 10 ⁷ V/A	
RF OUTPUT Conversion Gain ²⁾	0.53 × 10 ³ V/W 0.53 × 10 ⁴ V/W 0.53 × 10 ⁵ V/W 0.53 × 10 ⁶ V/W 0.53 × 10 ⁷ V/W	1 × 10 ³ V/W 1 × 10 ⁴ V/W 1 × 10 ⁵ V/W 1 × 10 ⁶ V/W 1 × 10 ⁷ V/W
CW Saturation Power	9 mW @ 820 nm	4.5 mW @ 1550 nm
Minimum NEP (DC to 100 MHz)	1.3 pW/√Hz	0.7 pW/√Hz
Integrated Noise (DC to 100 MHz)	100 nW _{RMS}	65 nW _{RMS}
Overall Output Voltage Noise (RMS) at Transimpedance Gain 10 ³ V/A Transimpedance Gain 10 ⁴ V/A Transimpedance Gain 10 ⁵ V/A Transimpedance Gain 10 ⁶ V/A Transimpedance Gain 10 ⁷ V/A	0.50 mV 0.80 mV 1.0 mV 1.1 mV 2.0 mV	

Note Make sure that the transimpedance gain is set in such way, that RF OUTPUT is below saturation threshold!

¹⁾ Values are given for high impedance load. For a 50 Ω load, values to be divided by 2.

²⁾ Values are given at peak responsivity of the detector, for high impedance load. For a 50 Ω load, values to be divided by 2.

PDB450A

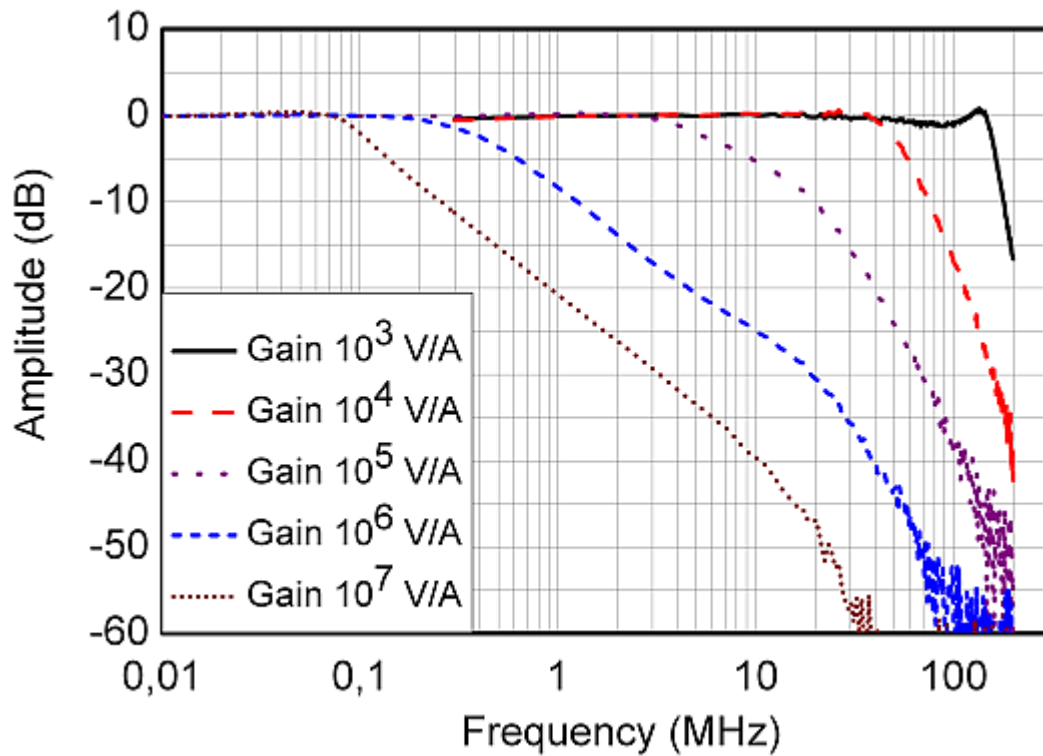

PDB450A: Typical RF OUTPUT Frequency Response at different gain settings

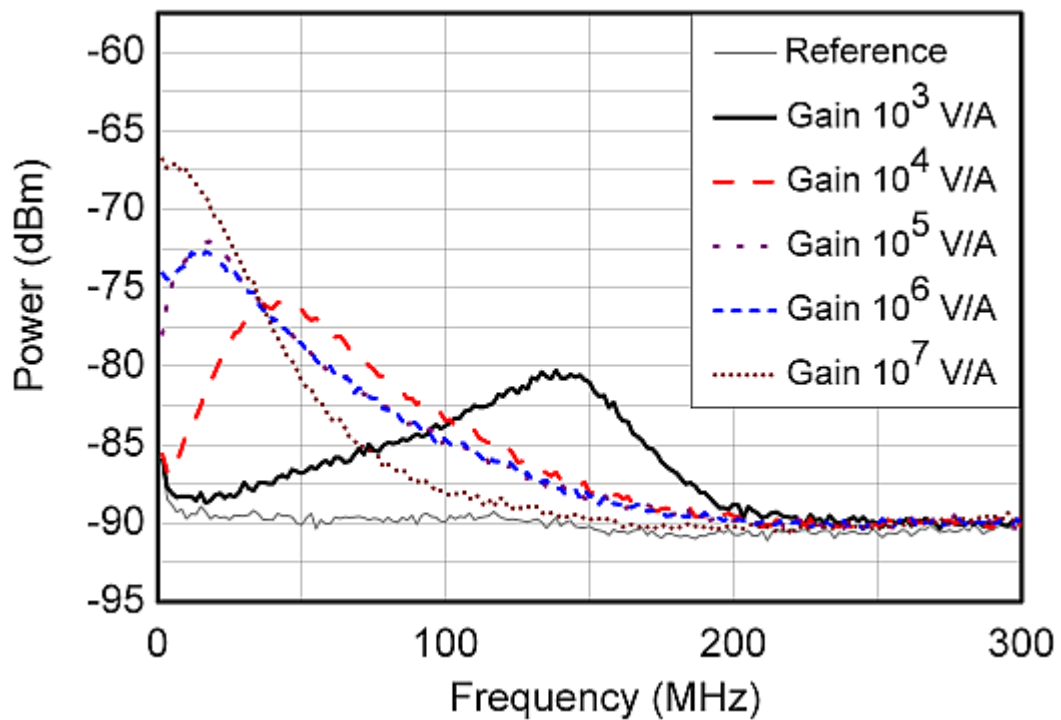

PDB450A: RF OUTPUT Spectral Noise at different gain settings

PDB450C

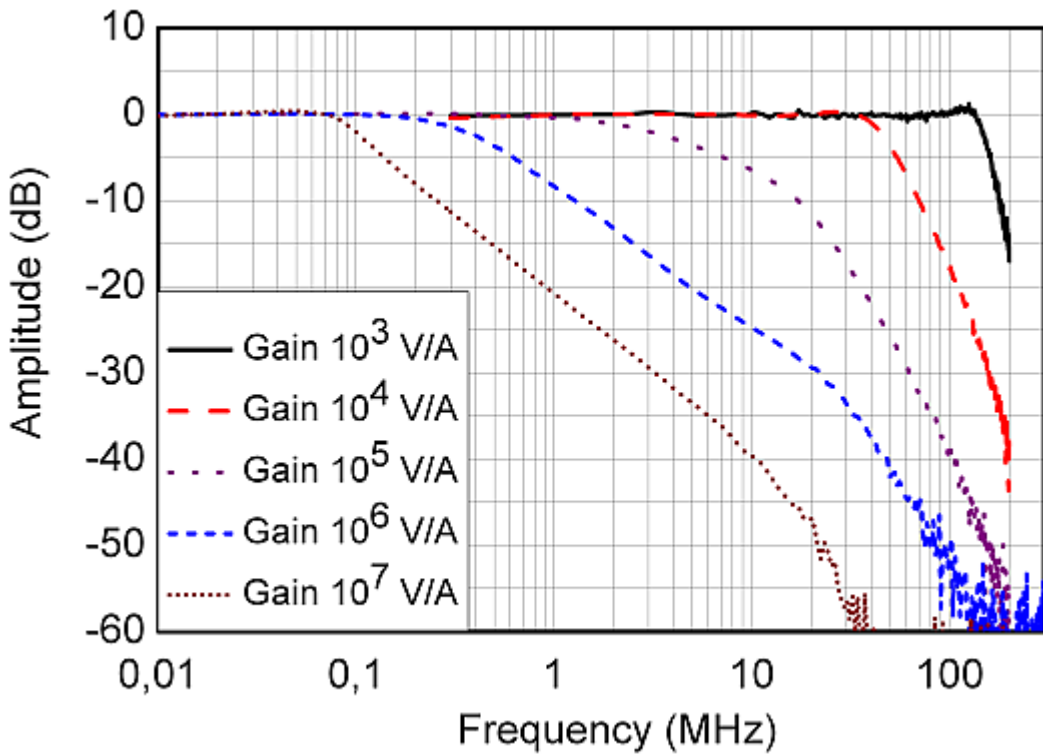

PDB450C: Typical RF OUTPUT Frequency Response at different gain settings

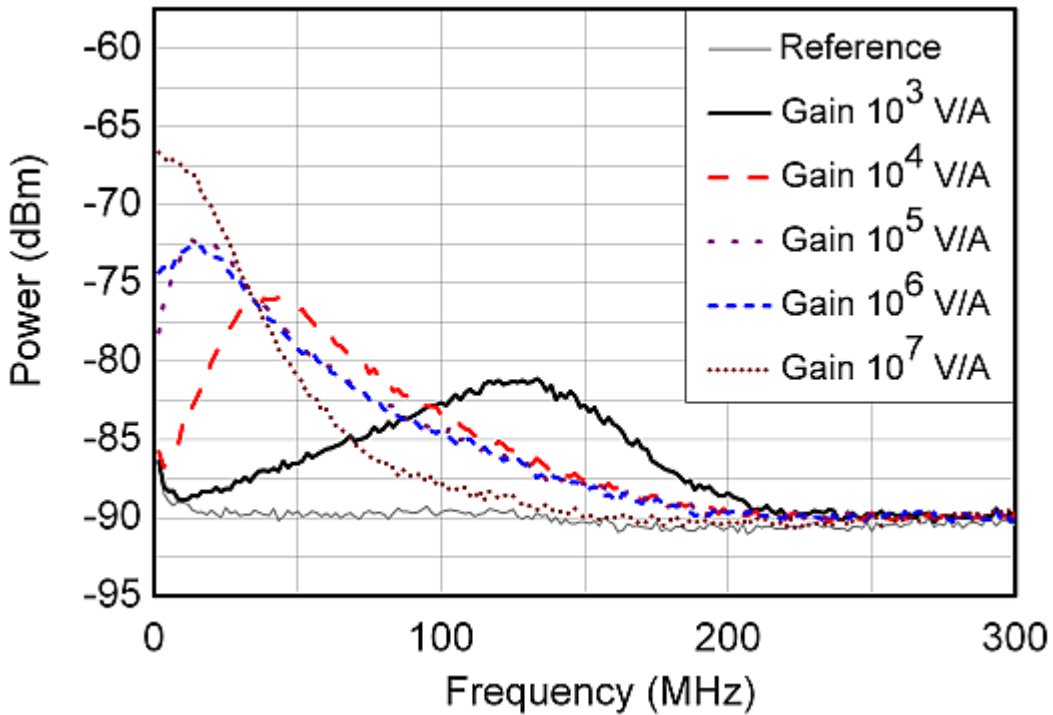

PDB450C: RF OUTPUT Spectral Noise at different gain settings

5.1.6 PDB460x Individual Technical Data

	PDB460A	PDB460C
Detector Material / Type	Si / PIN	InGaAs / PIN
Operating Wavelength Range	320 - 1000 nm	800 - 1700 nm
Max. Responsivity, typ.	0.50 A/W	1.0 A/W
Detector Active Area Ø	0.4 mm	0.15 mm
RF OUTPUT Bandwidth (-3 dB)	DC - 200 MHz	
CMRR	>25 dB (typ. >35 dB)	
RF OUTPUT Transimpedance Gain ¹⁾	30×10^3 V/A	
RF OUTPUT Conversion Gain ²⁾	16×10^3 V/W	30×10^3 V/W
CW Saturation Power	225 μ W @ 820 nm	120 μ W @ 1550 nm
Minimum NEP (DC to 10 MHz)	13.2 pW/ \sqrt Hz	6.0 pW/ \sqrt Hz
Integrated Noise (DC to 100 MHz)	290 nW _{RMS}	130 nW _{RMS}
Overall Output Voltage Noise	2.6 mV _{RMS}	2.3 mV _{RMS}

Attention PDB460C: FC receptacles are not removable!

¹⁾ Values are given for high impedance load. For a 50 Ω load, values to be divided by 2.

²⁾ Values are given at peak responsivity of the detector, for high impedance load. For a 50 Ω load, values to be divided by 2.

PDB460A

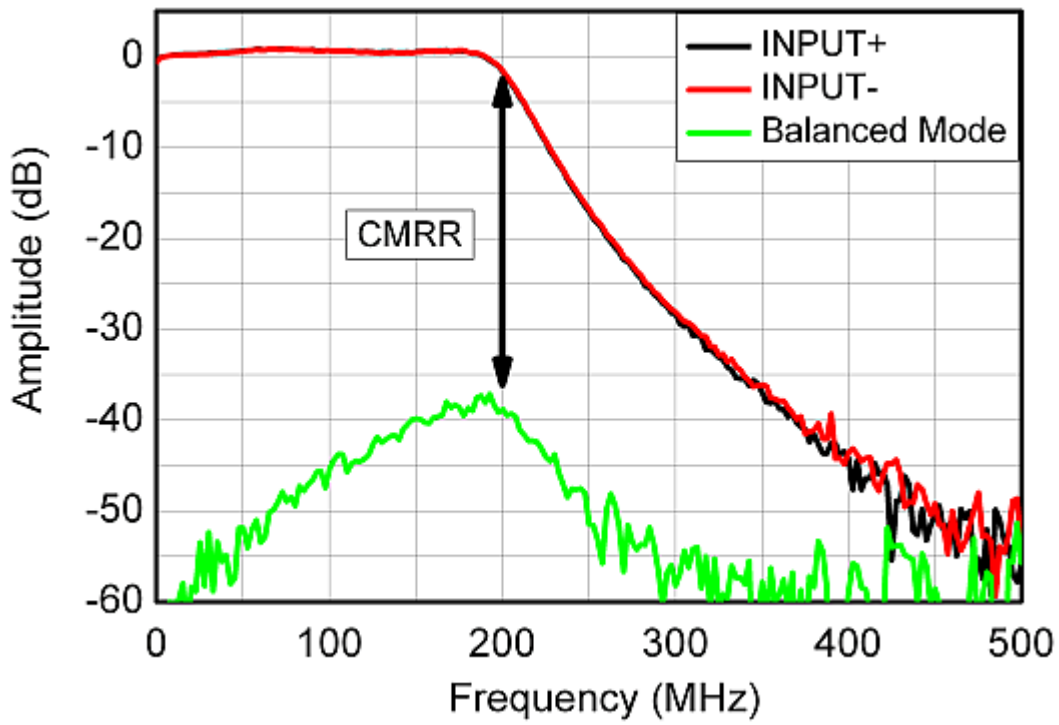

PDB460A: Typical RF OUTPUT Frequency Response

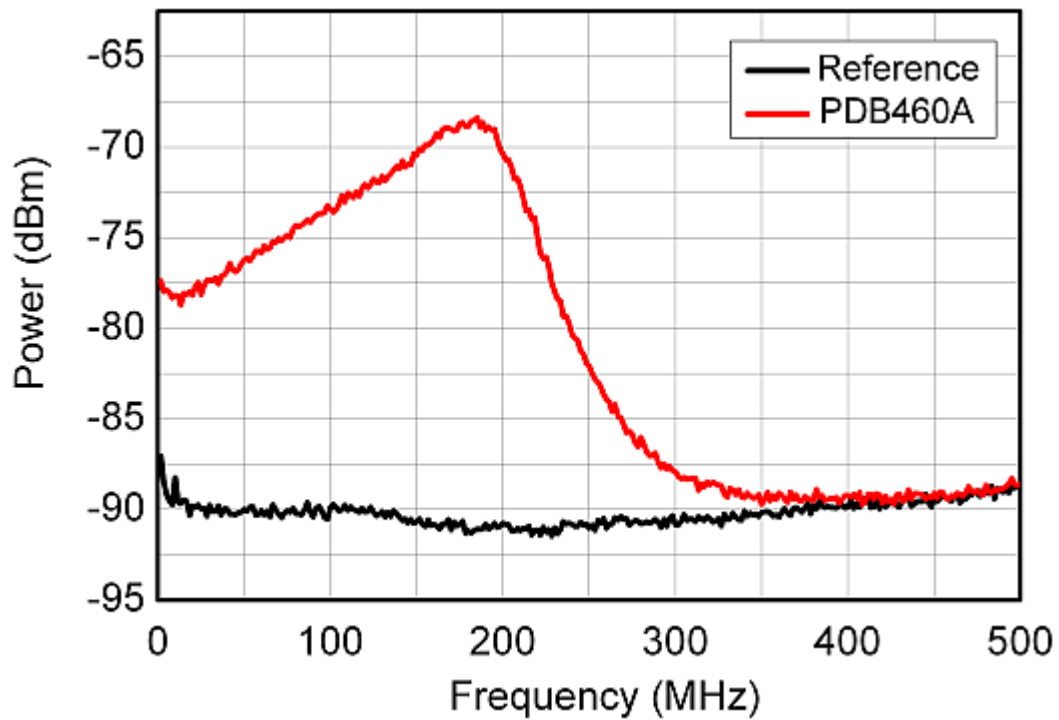

PDB460A: RF OUTPUT Spectral Noise

PDB460C

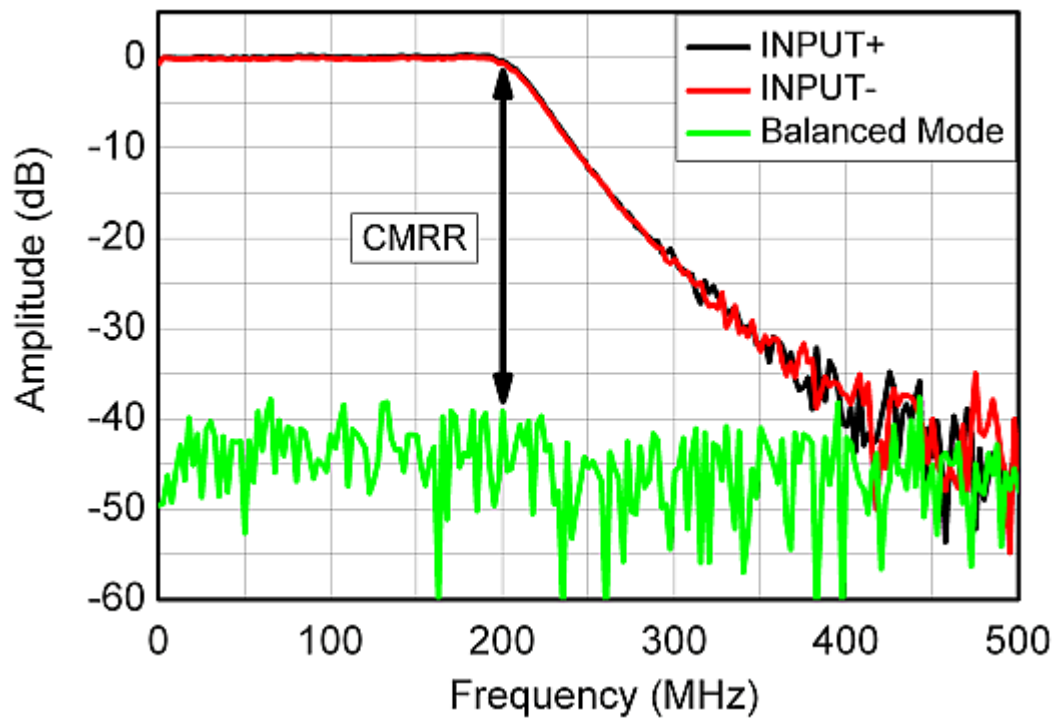
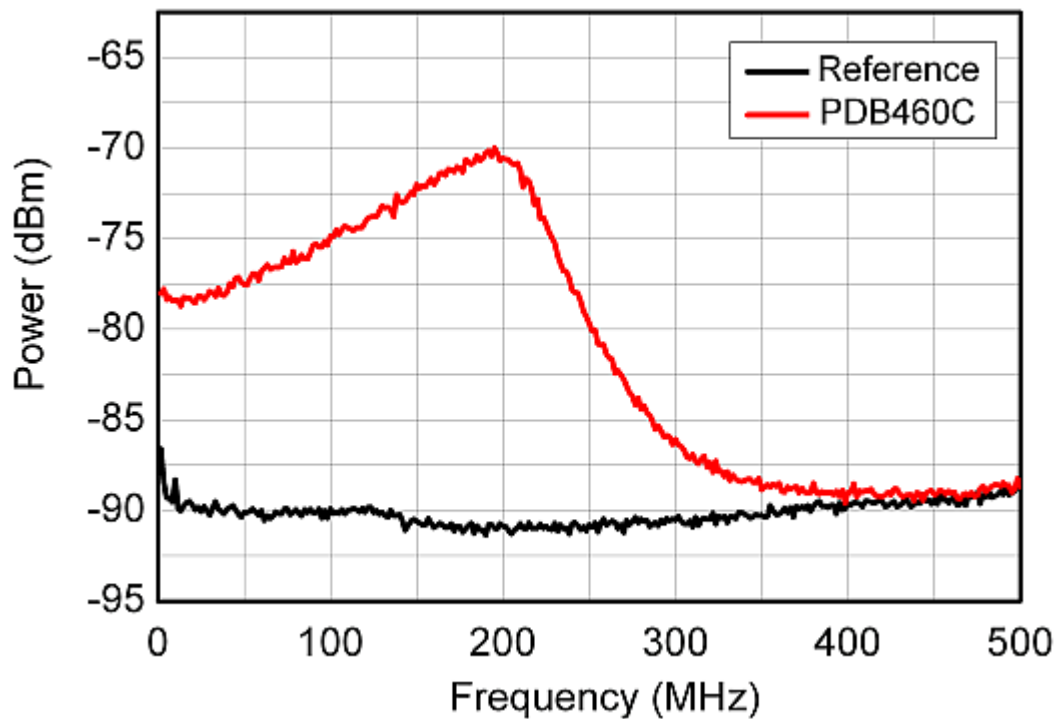
*PDB460C: Typical RF OUTPUT Frequency Response**PDB460C: RF OUTPUT Spectral Noise*

5.2 Dimensions

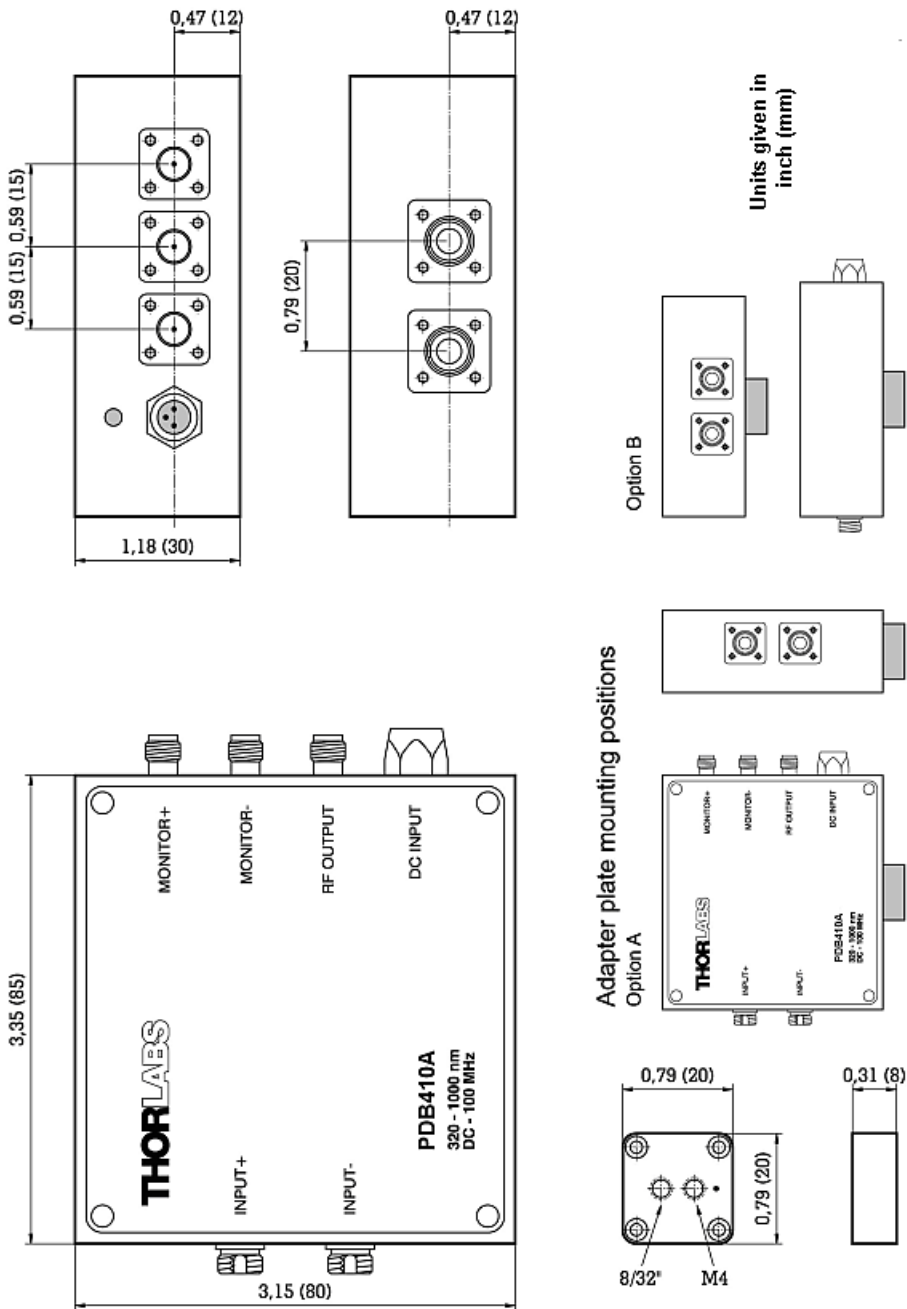

Mechanical Drawing PDB410, PDB420, PDB430, PDB440, PDB460, PDB480C

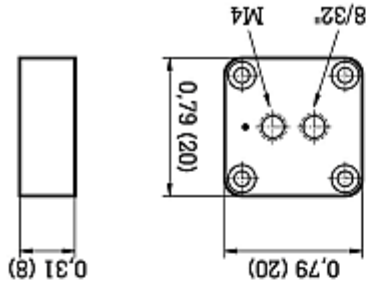
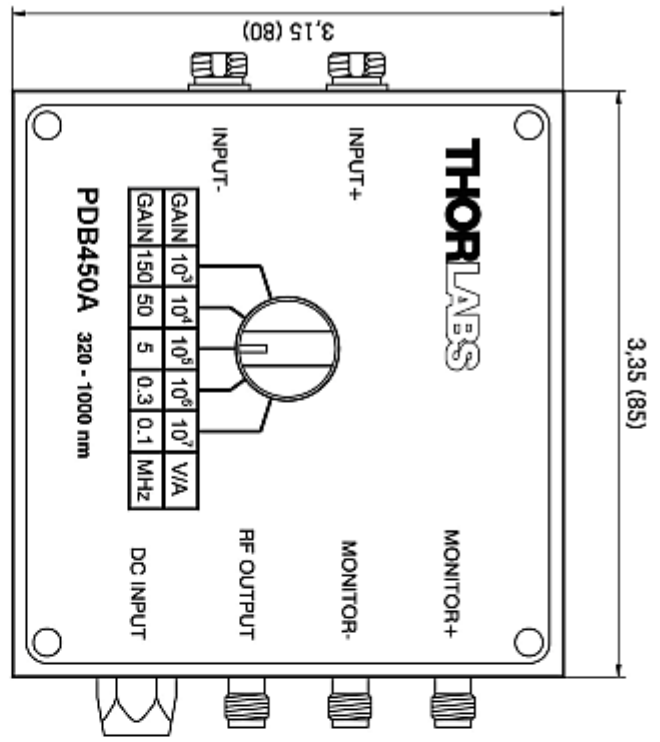

Adapter plate mounting positions
Option A

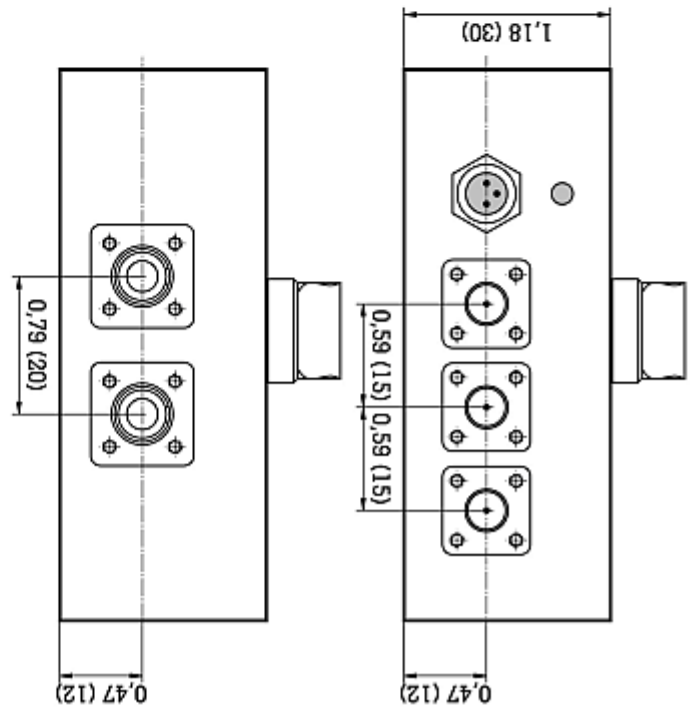
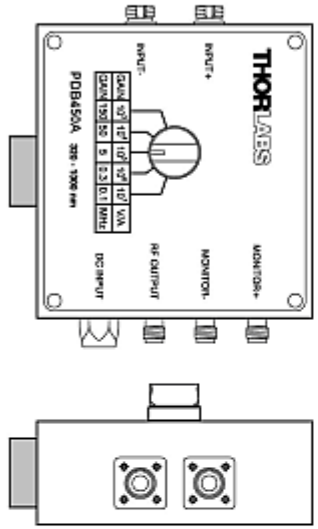

Option B

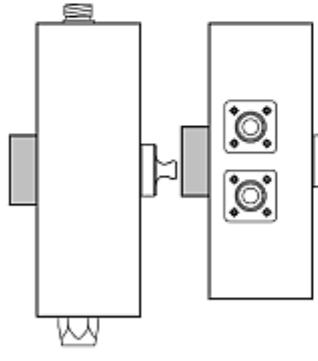

Units given in
Inch (mm)

Mechanical Drawing PDB450

5.3 Certifications and Compliances

EU Declaration of Conformity

in accordance with EN ISO 17050-1:2010

We Thorlabs GmbH

Of Hans-Boeckler-Str. 6, 85221 Dachau/München, Deutschland

in accordance with the following Directive(s):

2006/95/EC	Low Voltage Directive (LVD)
2004/108/EC	Electromagnetic Compatibility (EMC) Directive
2011/65/EU	Restriction of Use of Certain Hazardous Substances (RoHS)

hereby declare that:

Model: **PDB4 Series**

Equipment: **Balanced Receiver**

is in conformity with the applicable requirements of the following documents:

EN61010 -1	Safety Requirements for Electrical Equipment for Measurement, Control and Laboratory Use.	2010
EN61326-1	Electrical Equipment for Measurement, Control and Laboratory Use - EMC Requirements	2013

and which, issued under the sole responsibility of Thorlabs, is in conformity with Directive 2011/65/EU of the European Parliament and of the Council of 8th June 2011 on the restriction of the use of certain hazardous substances in electrical and electronic equipment, for the reason stated below:

does not contain substances in excess of the maximum concentration values tolerated by weight in homogenous materials as listed in Annex II of the Directive

I hereby declare that the equipment named has been designed to comply with the relevant sections of the above referenced specifications, and complies with all applicable Essential Requirements of the Directives.

Signed:

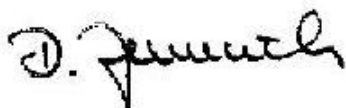

On: 19 September 2014

Name: Dorothee Jennrich

Position: General Manager

EDC - PDB4 Series -2014-09-19

CE¹⁴

5.4 Warranty

Thorlabs warrants material and production of the PDB4xx Series for a period of 24 months starting with the date of shipment. During this warranty period Thorlabs will see to defaults by repair or by exchange if these are entitled to warranty.

For warranty repairs or service the unit must be sent back to Thorlabs. The customer will carry the shipping costs to Thorlabs, in case of warranty repairs Thorlabs will carry the shipping costs back to the customer.

If no warranty repair is applicable the customer also has to carry the costs for back shipment.

In case of shipment from outside EU duties, taxes etc. which should arise have to be carried by the customer.

Thorlabs warrants the hard- and software determined by Thorlabs for this unit to operate fault-free provided that they are handled according to our requirements. However, Thorlabs does not warrant a fault free and uninterrupted operation of the unit, of the software or firmware for special applications nor this instruction manual to be error free. Thorlabs is not liable for consequential damages.

Restriction of warranty

The warranty mentioned before does not cover errors and defects being the result of improper treatment, software or interface not supplied by us, modification, misuse or operation outside the defined ambient stated by us or unauthorized maintenance.

Further claims will not be consented to and will not be acknowledged. Thorlabs does explicitly not warrant the usability or the economical use for certain cases of application.

Thorlabs reserves the right to change this instruction manual or the technical data of the described unit at any time.

5.5 Copyright and Exclusion of Reliability

Thorlabs has taken every possible care in preparing this Operation Manual. We however assume no liability for the content, completeness or quality of the information contained therein. The content of this manual is regularly updated and adapted to reflect the current status of the software. We furthermore do not guarantee that this product will function without errors, even if the stated specifications are adhered to.

Under no circumstances can we guarantee that a particular objective can be achieved with the purchase of this product.

Insofar as permitted under statutory regulations, we assume no liability for direct damage, indirect damage or damages suffered by third parties resulting from the purchase of this product. In no event shall any liability exceed the purchase price of the product.

Please note that the content of this User Manual is neither part of any previous or existing agreement, promise, representation or legal relationship, nor an alteration or amendment thereof. All obligations of *Thorlabs* result from the respective contract of sale, which also includes the complete and exclusively applicable warranty regulations. These contractual warranty regulations are neither extended nor limited by the information contained in this User Manual. Should you require further information on this product, or encounter specific problems that are not discussed in sufficient detail in the User Manual, please contact your local *Thorlabs* dealer or system installer.

All rights reserved. This manual may not be reproduced, transmitted or translated to another language, either as a whole or in parts, without the prior written permission of *Thorlabs*.

Copyright © Thorlabs 2014. All rights reserved.

5.6 Thorlabs 'End of Life' Policy (WEEE)

As required by the WEEE (Waste Electrical and Electronic Equipment Directive) of the European Community and the corresponding national laws, Thorlabs offers all end users in the EC the possibility to return “end of life” units without incurring disposal charges.

This offer is valid for Thorlabs electrical and electronic equipment

- sold after August 13th 2005
- marked correspondingly with the crossed out “wheelie bin” logo (see figure below)
- sold to a company or institute within the EC
- currently owned by a company or institute within the EC
- still complete, not disassembled and not contaminated

As the WEEE directive applies to self contained operational electrical and electronic products, this “end of life” take back service does not refer to other Thorlabs products, such as

- pure OEM products, that means assemblies to be built into a unit by the user (e. g. OEM laser driver cards)
- components
- mechanics and optics
- left over parts of units disassembled by the user (PCB's, housings etc.).

Waste treatment on your own responsibility

If you do not return an “end of life” unit to Thorlabs, you must hand it to a company specialized in waste recovery. Do not dispose of the unit in a litter bin or at a public waste disposal site.

WEEE Number (Germany) : DE97581288

Ecological background

It is well known that waste treatment pollutes the environment by releasing toxic products during decomposition. The aim of the European RoHS Directive is to reduce the content of toxic substances in electronic products in the future.

The intent of the WEEE Directive is to enforce the recycling of WEEE. A controlled recycling of end-of-life products will thereby avoid negative impacts on the environment.



*Crossed out
"Wheelie Bin" symbol*

5.7 Thorlabs Worldwide Contacts

USA, Canada, and South America

Thorlabs, Inc.
56 Sparta Avenue
Newton, NJ 07860
USA
Tel: 973-579-7227
Fax: 973-300-3600
www.thorlabs.com
www.thorlabs.us (West Coast)
Email: sales@thorlabs.com
Support: techsupport@thorlabs.com

UK and Ireland

Thorlabs Ltd.
1 Saint Thomas Place, Ely
Cambridgeshire CB7 4EX
United Kingdom
Tel: +44-1353-654440
Fax: +44-1353-654444
www.thorlabs.com
Email: sales.uk@thorlabs.com
Support: techsupport.uk@thorlabs.com

Europe

Thorlabs GmbH
Hans-Böckler-Str. 6
85221 Dachau
Germany
Tel: +49-8131-5956-0
Fax: +49-8131-5956-99
www.thorlabs.de
Email: europe@thorlabs.com

Scandinavia

Thorlabs Sweden AB
Mölnsdalsvägen 3
412 63 Göteborg
Sweden
Tel: +46-31-733-30-00
Fax: +46-31-703-40-45
www.thorlabs.com
Email: scandinavia@thorlabs.com

France

Thorlabs SAS
109, rue des Côtes
78600 Maisons-Laffitte
France
Tel: +33-970 444 844
Fax: +33-811 38 17 48
www.thorlabs.com
Email: sales.fr@thorlabs.com

Brazil

Thorlabs Vendas de Fotônicos Ltda.
Rua Riachuelo, 171
São Carlos, SP 13560-110
Brazil
Tel: +55-16-3413 7062
Fax: +55-16-3413 7064
www.thorlabs.com
Email: brasil@thorlabs.com

Japan

Thorlabs Japan, Inc.
Higashi Ikebukuro
Q Building 2nd Floor 2-23-2
Toshima-ku, Tokyo 170-0013
Japan
Tel: +81-3-5979-8889
Fax: +81-3-5979-7285
www.thorlabs.jp
Email: sales@thorlabs.jp

China

Thorlabs China
Room A101, No. 100
Lane 2891, South Qilianshan Road
Putuo District
Shanghai 200331
China
Tel: +86-21-60561122
Fax: +86-21-32513480
www.thorlabs.hk
Email: chinasales@thorlabs.com