

**NOTES:**

- FRONT VIEW DIMENSIONS VALID WHEN AT FREE STATE AND POWERED OFF (OR WHEN AT 0V).
- REFER TO INSTRUCTION MANUAL FOR GEOMETRY DETAILS IN OPERATION.

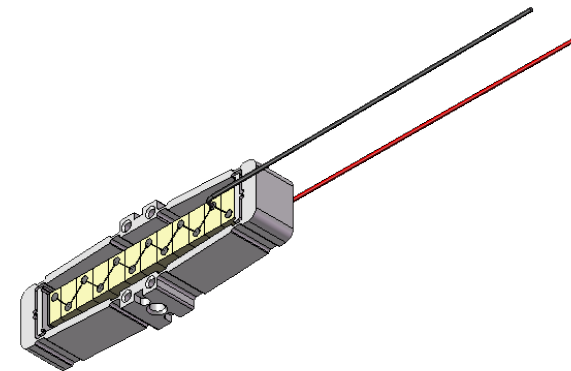
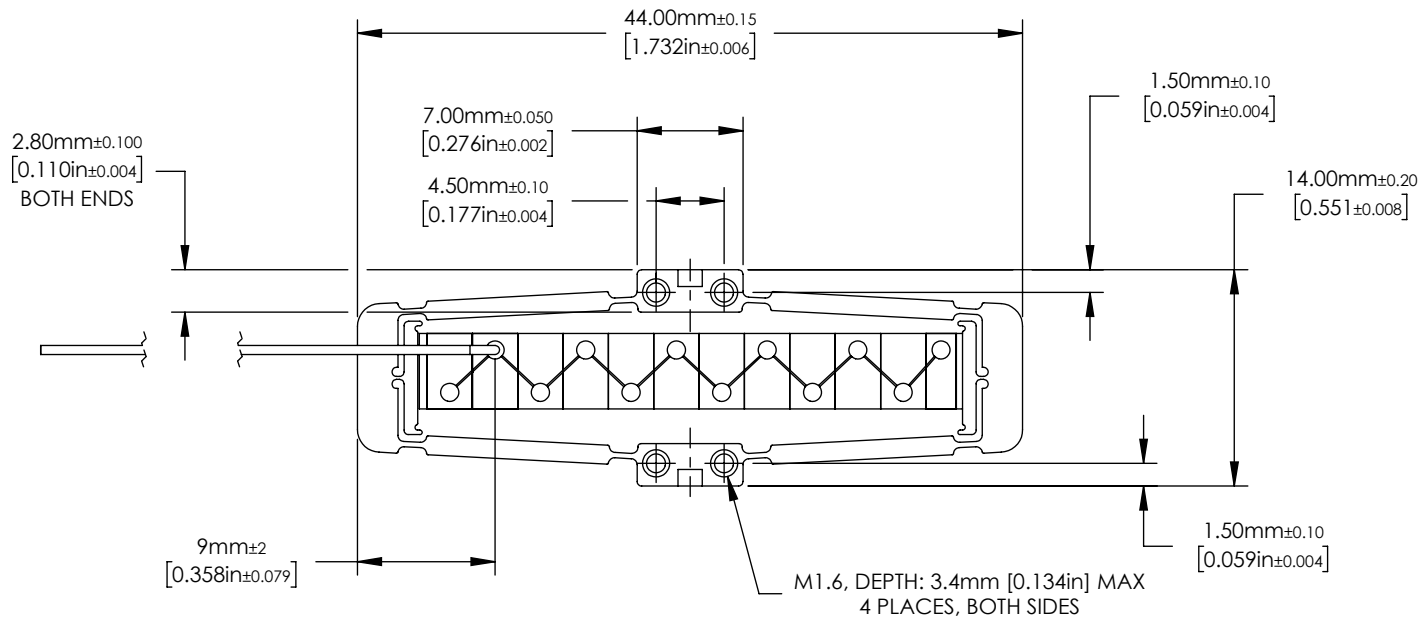
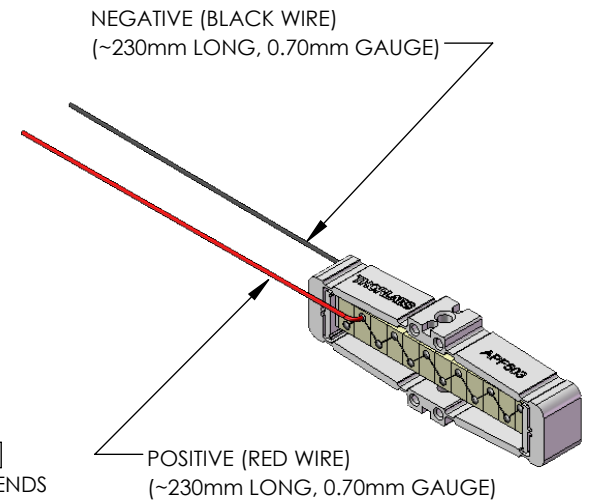
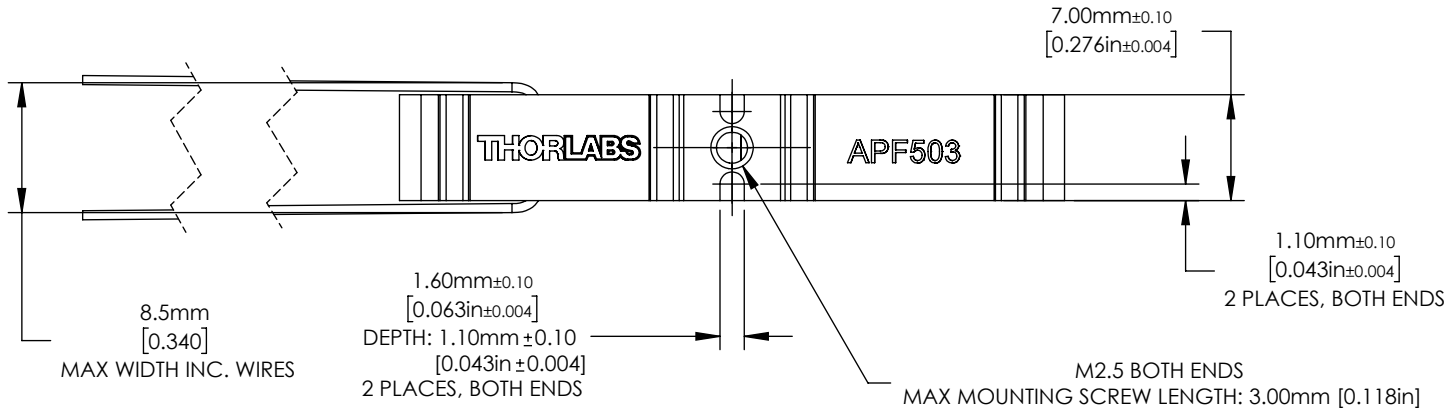

FOR INFORMATION ONLY  
NOT FOR MANUFACTURING PURPOSES

DRAWING PROJECTION				<b>THORLABS</b> www.thorlabs.com AMPLIFIED PIEZO FLEXURE ACTUATOR, 5 SERIES, 390um TRAVEL	
NAME	DATE				
DRAWN	SF	25/JUL/17			MATERIAL
APPROVAL	DC	25/JUL/17			
COPYRIGHT © 2017 BY THORLABS				N/A	
VALUES IN PARENTHESIS ARE CALCULATED AND MAY CONTAIN ROUND OFF ERRORS		ITEM #	APF503		APPROX WEIGHT
				REV A	
				0.02 kg	