

FOR INFORMATION ONLY
NOT FOR MANUFACTURING PURPOSES

DRAWING PROJECTION		
NAME	TB	DATE
DRAWN	TB	28/JAN/16
APPROVAL	PN	28/JAN/16
COPYRIGHT © 2016 BY THORLABS		
VALUES IN PARENTHESIS ARE CALCULATED AND MAY CONTAIN ROUND OFF ERRORS		

THORLABS www.thorlabs.com	
DUAL-CHANNEL PMT MODULE	
MATERIAL	REV B
N/A	
ITEM #	APPROX WEIGHT
PMTSS2	1.4 kg

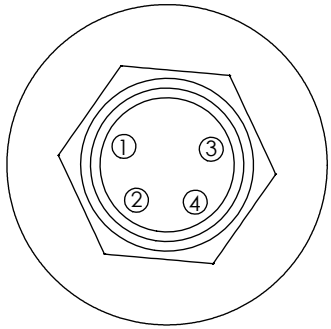

DETAIL A
SCALE 2.5 : 1

PIN	DESCRIPTION
1	V+ POWER SUPPLY INPUT
2	V CONTROL (0.25V TO 1.2V)
3	NO CONNECT
4	GND POWER SUPPLY RETURN

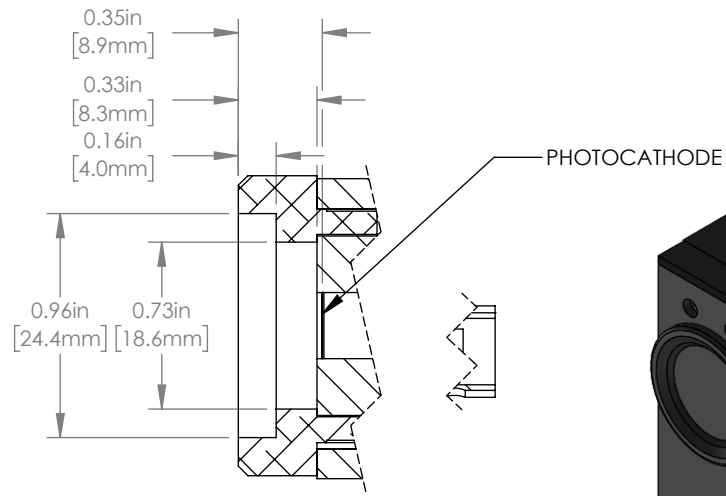

SECTION B-B
SCALE 1.25 : 1



C-MOUNT (Ø 1.00-32) SERIES
INTERNAL THREAD

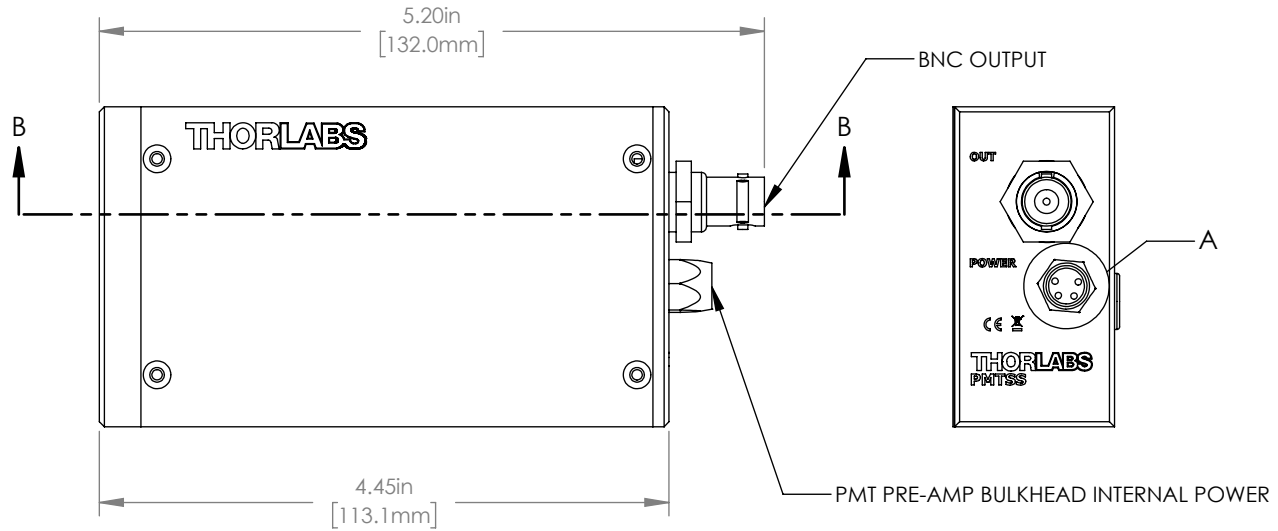
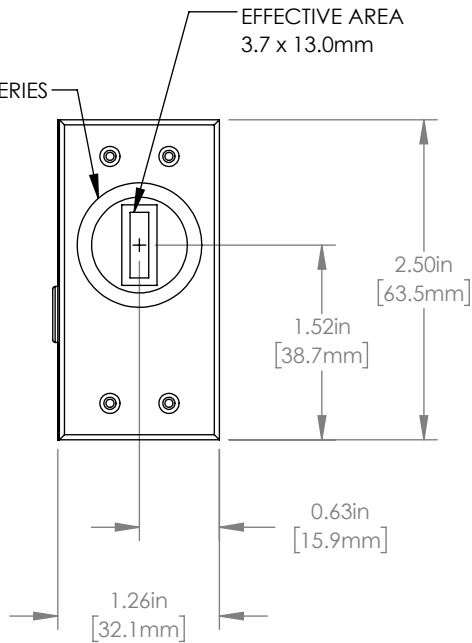

FOR INFORMATION ONLY
NOT FOR MANUFACTURING PURPOSES

DRAWING PROJECTION

	NAME	DATE
DRAWN	TB	28/JAN/16
APPROVAL	PN	28/JAN/16

COPYRIGHT © 2016 BY THORLABS
VALUES IN PARENTHESIS ARE CALCULATED
AND MAY CONTAIN ROUND OFF ERRORS

THORLABS
www.thorlabs.com

SINGLE-CHANNEL PMT MODULE

MATERIAL N/A REV B



ITEM # PMTSS2 APPROX WEIGHT 0.3 kg

COMPONENT TABLE

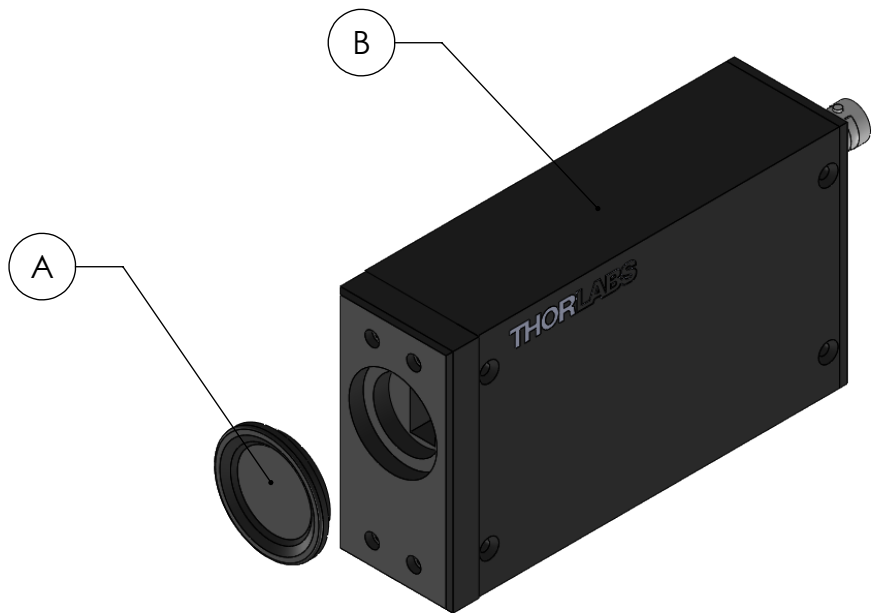
(A)	C-MOUNT BODY CAP
(B)	PMTSS



FOR INFORMATION ONLY
NOT FOR MANUFACTURING PURPOSES

DRAWING PROJECTION			 		 www.thorlabs.com	
	NAME	DATE	SINGLE-CHANNEL PMT MODULE			
DRAWN	TB	28/JAN/16	MATERIAL			REV
APPROVAL	PN	28/JAN/16	N/A			B
COPYRIGHT © 2016 BY THORLABS			ITEM #		APPROX WEIGHT	
VALUES IN PARENTHESIS ARE CALCULATED AND MAY CONTAIN ROUND OFF ERRORS			PMTSS2		0.3 kg	