



# **ELL20(/M) and ELL20K(/M)**

## **Linear Translation Stage**

### Operating Manual



Original Instructions

---

# Table of Contents

<b>Chapter 1</b>	<b>Introduction</b> .....	<b>1</b>
<b>Chapter 2</b>	<b>Safety</b> .....	<b>2</b>
	<b>2.1 General Warnings and Cautions</b> .....	<b>2</b>
<b>Chapter 3</b>	<b>Installation</b> .....	<b>3</b>
	<b>3.1 Environmental Conditions</b> .....	<b>3</b>
	<b>3.2 Mounting</b> .....	<b>4</b>
<b>Chapter 4</b>	<b>Operation</b> .....	<b>6</b>
	<b>4.1 Getting Started</b> .....	<b>6</b>
	4.1.1 Position Error Compensation .....	6
	<b>4.2 Controlling the Stage</b> .....	<b>6</b>
	4.2.1 Hand-held Controller.....	7
	4.2.2 Software Control.....	8
	4.2.3 Communications Protocol .....	9
	4.2.4 Connecting Multiple Devices .....	9
	4.2.5 Controlling the stage without the Handset.....	9
	<b>4.3 Frequency Search</b> .....	<b>11</b>
	<b>4.4 Periodic Cycling of Devices Over Full Range of Travel</b> .....	<b>11</b>
	<b>4.5 Restoring Factory Settings</b> .....	<b>11</b>
	<b>4.6 Simultaneous Movement of Devices</b> .....	<b>11</b>
<b>Chapter 5</b>	<b>Troubleshooting and FAQ</b> .....	<b>12</b>
	<b>5.1 Frequently Asked Questions</b> .....	<b>12</b>
	<b>5.2 Notes on Making a Picoflex Cable for Use when Daisy Chain Devices</b> .....	<b>14</b>
<b>Chapter 6</b>	<b>Specifications</b> .....	<b>16</b>
<b>Chapter 7</b>	<b>Regulatory</b> .....	<b>18</b>
	<b>7.1 Declarations of Conformity</b> .....	<b>18</b>
	7.1.1 For Customers in Europe.....	18
	7.1.2 For Customers In The USA.....	18
<b>Chapter 8</b>	<b>Thorlabs Worldwide Contacts</b> .....	<b>19</b>

---

## Chapter 1 Introduction

The ELL20 Linear Translation Stage is part of the Thorlabs series of resonant piezo motor circuits and bare modules for OEM applications. The resonant piezo design of these motors offers fast response times and precise positioning, and therefore they are particularly useful in scanning applications.

The high-speed digital signal processing (DSP) architecture supports a multi-drop serial communication protocol, and a set of digital IO lines allows the user to control the movement and state manually by switching the lines high (5 V) or low (0 V).

The stage is designed for closed loop applications requiring linear positioning over a 60 mm (2.4") travel range, with a theoretical resolution of 0.98  $\mu\text{m}$ .

**Note**

The module must be powered via an external 5V power supply unit (PSU). A suitable PSU is supplied in the kit. For customers wanting to use a third party PSU, the Connector on the interface board is a DC Jack connector, 6.3mm OD (GND), 2.1mm ID (+5V).

A hand-held controller is supplied with the ELL20K evaluation kit to allow homing and manual jogging and/or positioning. The unit can also be driven remotely via PC-based software, downloaded from [www.thorlabs.com](http://www.thorlabs.com). A compatible USB driver and source code are included in the software download package.

## Chapter 2 Safety

For the continuing safety of the operators of this equipment, and the protection of the equipment itself, the operator should take note of the Warnings, Cautions and Notes throughout this handbook and, where visible, on the product itself.

**Warning: Risk of Electrical Shock**

Given when there is a risk of electrical shock.

**Warning**

Given when there is a risk of injury to the user..

**Caution**

Given when there is a possibility of damage to the product.

**Note**

Clarification of an instruction or additional information.

**Warning**

When connecting the stage to a PC, ensure that the PC is switched ON before connecting the stage to the USB port. Failure to do this could damage the PC.

If this equipment is used in a manner not specified by the manufacturer, the protection provided by the equipment may be impaired. In particular, excessive moisture may impair operation.

The equipment is susceptible to damage from electrostatic discharge. When handling the device, anti-static precautions must be taken and suitable discharge appliances must be worn.



Spillage of fluid, such as sample solutions, should be avoided. If spillage does occur, clean up immediately using absorbent tissue. Do not allow spilled fluid to enter the internal mechanism.

Do not expose the stage to magnetic fields as this could affect the positioning and homing sensor operation. An external magnetic field close to the sensor should be below +/- 5 mT.

If the device is operated over a prolonged time period, the motor housing may become hot. This does not affect motor operation but may cause discomfort if contacted by exposed skin.

Do not bend the PCB. A bending load in excess of 500 g applied to the board may cause the PCB to deform, which will degrade the performance of the Stage.

Do not expose the stage to a strong infrared light (e.g. direct sunlight) as it could interfere with the operation of the position sensor.

During use do not place the PCB directly onto electro-conductive material e.g. an optical table top or breadboard.

**Caution**

The home sensor of the device relies on a 950nm led which can leak from the device. This should be taken into consideration for environments that are especially sensitive to foreign light sources.

## Chapter 3 Installation

### 3.1 Environmental Conditions

**Warning**

Operation outside the following environmental limits may adversely affect operator safety.

Location	Indoor use only
Maximum altitude	2000 m
Temperature range	15° C to 40° C
Maximum Humidity	Less than 80% RH (non-condensing) at 31° C

To ensure reliable operation the unit should not be exposed to corrosive agents or excessive moisture, heat or dust.

Do not expose the stage to magnetic fields as this could affect the positioning and homing sensor operation.

If the unit has been stored at a low temperature or in an environment of high humidity, it must be allowed to reach ambient conditions before being powered up.

The unit is not designed to be used in explosive environments.

The unit is not designed for continuous operation. Lifetime will depend on several factors, e.g. load, number of homing operations, number of frequency searches etc. The minimum lifetime is 100 km. See Chapter 5 for more details.

### 3.2 Mounting



**Warning**

The safety of any system incorporating this equipment is the responsibility of the person performing the installation.



**Cautions**

Although the module can tolerate up to 8 kV of air discharge, it must be treated as ESD sensitive device. When handling the device, anti-static precautions must be taken and suitable discharge appliances must be worn.

When handling the stage, take care not to touch the wires to the motors.



Do not bend the wires over the motor spring as this affects the performance of the unit.

Do not allow the wires to contact other moving parts.

The ribbon cable connector is made of plastic and is not particularly robust. Do not use force when making connections. Unnecessary or repeated plugging in and unplugging should be avoided or the connector may fail.

Do not expose the stage to magnetic fields as this could affect the positioning and homing sensor operation. An external magnetic field close to the sensor should be below +/- 5 mT.

The recommended mounting orientation is horizontal. A base plate is shipped fitted to the stage to allow mounting to a standard 1" or 25 mm pitch optical table or breadboard. If required, a grooved top plate (MMP1(/M)) or tapped top plate (RB13P1(/M)) can be purchased separately to allow components and devices to be mounted to the moving world – see Figure 2.

The stage can be mounted vertically, as long as the resulting motion is in the horizontal plane. The stage should not be mounted such that motion is vertical.

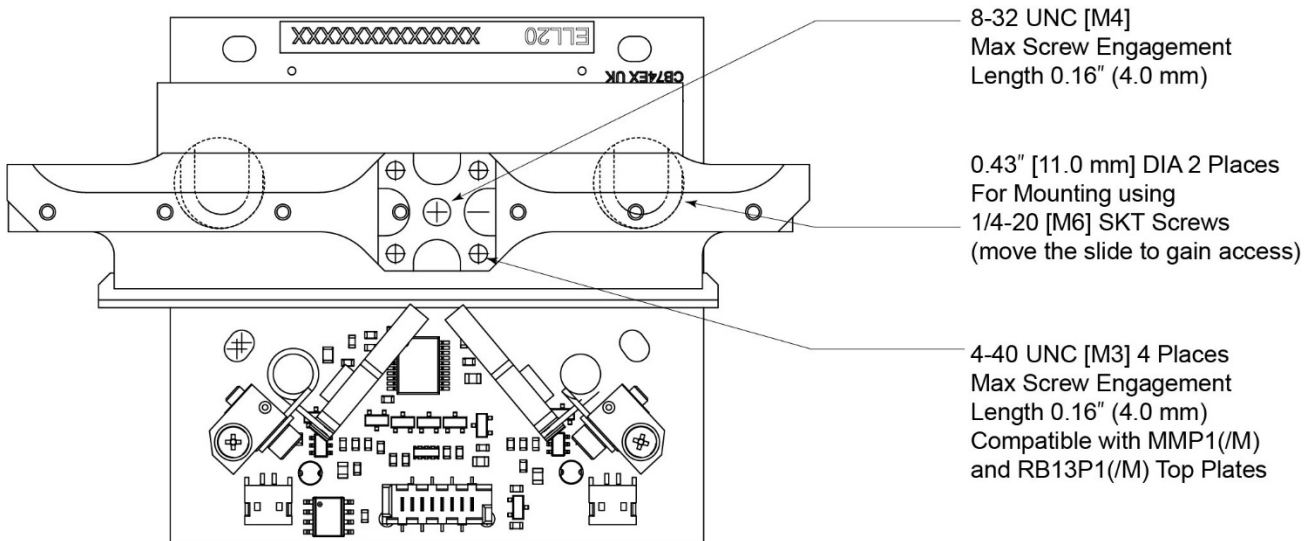

Figure 1 ELL20 Linear Stage

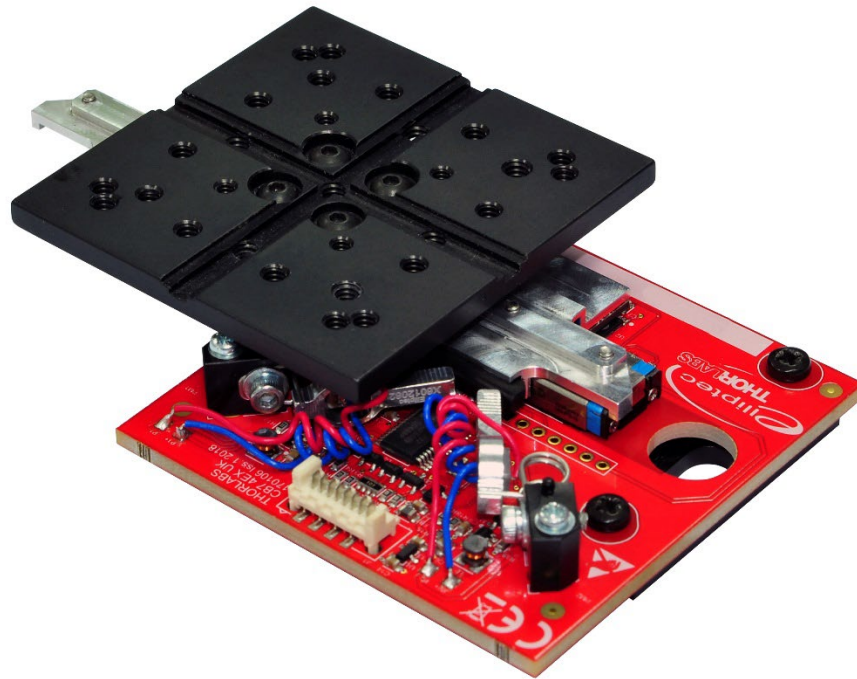

Figure 2 ELL20 with MMP1 Top Plate Fitted, Showing Stage in Backwards/Home Position

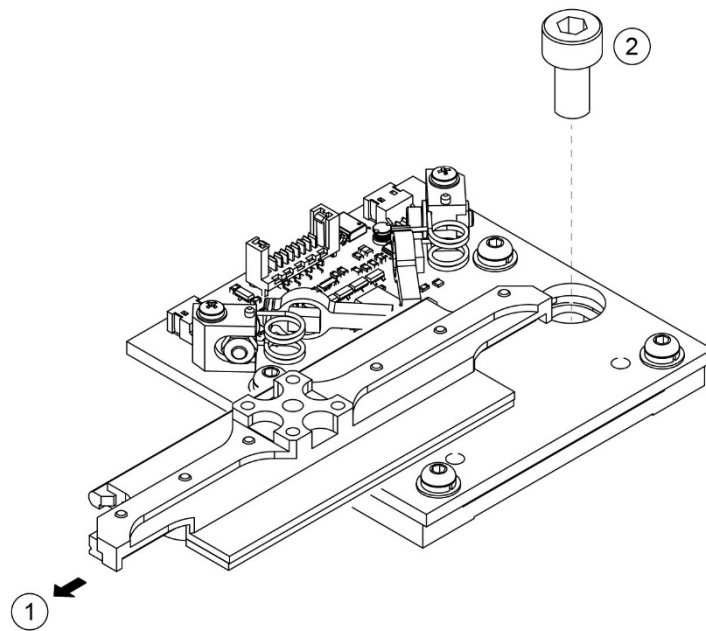



Figure 3 Fixing the ELL20 to the Work Surface

1. Carefully slide the moving world to one end of travel to gain access to the mounting holes as shown above.
2. Attach the stage to the work surface by passing appropriate standard fixings (not supplied) through the exposed hole in the PCB and base plate.
3. Slide the moving world to the other end of travel, and repeat item (2).

## Chapter 4 Operation

### 4.1 Getting Started

**Caution**

Although the module can tolerate up to 8 kV of air discharge, it must be treated as an ESD sensitive device. When handling the device, anti-static precautions must be taken and suitable anti-discharge appliances must be worn. 

Do not expose the Stage to magnetic fields as this could affect the positioning and homing sensor operation.

When power is applied, do not connect or disconnect the ribbon cable connecting the USB/PSU adapter to the Stage PCB. Always remove power before making connections.

The home sensor of the device relies on a 950nm led which can leak from the device. This should be taken into consideration for environments that are especially sensitive to foreign light sources.

**Warning**

If the device is operated over a prolonged time period, the motor housing may become hot. This does not affect motor operation but may cause discomfort if contacted by exposed skin. 

1. Perform the mechanical installation as detailed in Section 3.2
2. Turn on and boot up the host PC.
3. Connect the handset to the stage if required.

**Caution**

The unit is easily damaged by connections with incorrect polarity. Pin 1 of the connector on the PCB is marked with an arrow (see Figure 4 and Figure 5.) which should be adjacent to the red wire in the connecting cable.

4. Connect the stage to a 5V supply and switch 'ON'. (A 5 V PSU is supplied with the ELL20K).

**Caution**

Boot up the PC BEFORE connecting the USB cable. DO NOT connect a powered ELL kit to a PC that is not powered up and running.

5. Using the USB cable supplied, connect the handset to the PC.
6. If required, and wait for the drivers to be installed.
7. Home the stage. Homing is necessary to align the sensor and establish a datum from which all future moves are measured.

#### 4.1.1 Position Error Compensation

The stage has a positioning error compensation algorithm. When moving from one position to another, the stage detects the error between the requested and actual positions and will calculate an error compensation value, which is then applied to the next movement. A default compensation value is loaded on boot up, then the optimum value is calculated within the next 2 to 6 motions. Subsequently, the calculation is continually updated and is applied automatically.

### 4.2 Controlling the Stage

The stage can be controlled in three ways; via the handset, by the Elliptec software running on a PC, or by writing a custom application using the messages described in the communications protocol document. Homing and Jogging functionality can also be accessed by applying voltages to the digital lines on Connector J1. The modes of control are described in the following sections.

In all modes, when the unit is mounted in the recommended orientation, forward moves the stage to the right and backward moves to the left as shown in Figure 2.



### 4.2.1 Hand-held Controller

**Caution**

On power up the stage will move while the unit checks the sensors and then searches for the home position.

The ELL20K Evaluation Kit also contains a hand-held controller, which features two buttons (marked FW and BW) that allow control of the stage position. The handset also provides for connection to the host PC and to the external 5 V power supply. The external PSU connector allows the stage to be used in the absence of a PC, with control being achieved via the handset buttons.

The PWR LED (LED1) is lit green when power is applied to the unit. The INM LED (LED2) is lit red when the device being driven is in motion.

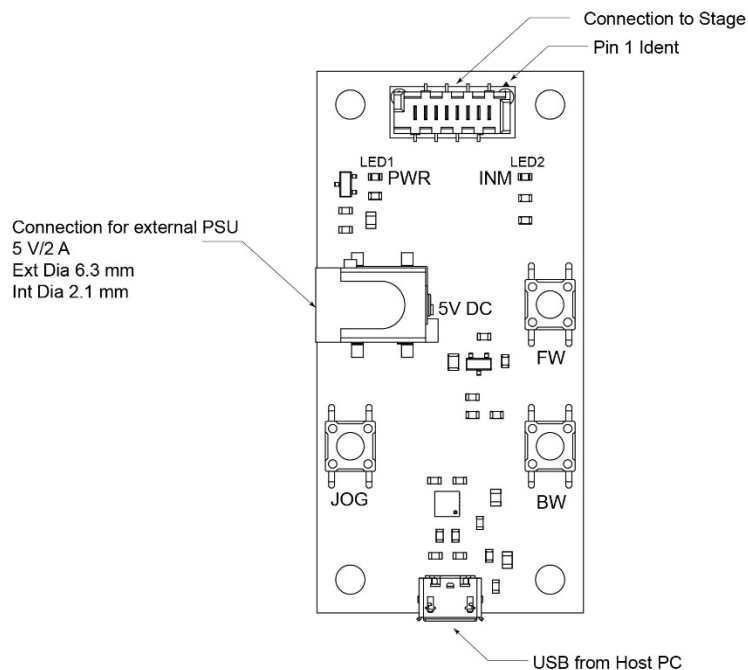

Figure 4 Handset Details

**Caution**

The stage must be homed before performing any Jog moves.

1. Connect the hand-held controller to the stage unit.
2. Connect the hand-held controller to the 5 V Power Supply and switch on.
3. Home the stage by pressing the BW button.
4. To jog forward, press and hold JOG and then press FW. The default jog step value is 2mm. The jog step size can be changed in the software GUI, see the help file for details.
5. To jog backward, press and hold JOG and then press BW.

### 4.2.2 Software Control

When connected to the host PC, the stage can be controlled remotely, via the Elliptec software.

1. Download the Elliptec software from the Downloads section at [www.thorlabs.com](http://www.thorlabs.com). Double click the saved .exe file and follow the on-screen instructions.
2. Connect the hand-held controller to the stage unit.
3. Connect the hand-held controller to the 5 V Power Supply and switch on.
4. Connect the hand-held controller to the PC USB port and wait for the drivers to be installed.
5. Run the Elliptec software.

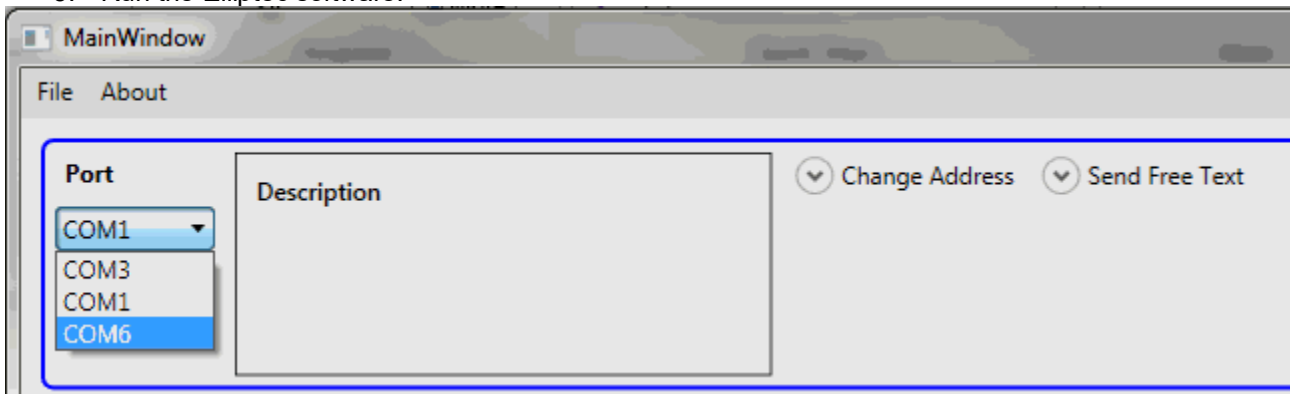

6. In the top left of the GUI panel displayed, select the COM port to which the device is connected, and click 'Connect'. The software will search the comms bus and enumerate the device.
7. Click the Home Offset 'Get' button, then click 'Home' to home the stage.
8. The GUI and device are now ready for use. See the help file supplied with the software for more information.

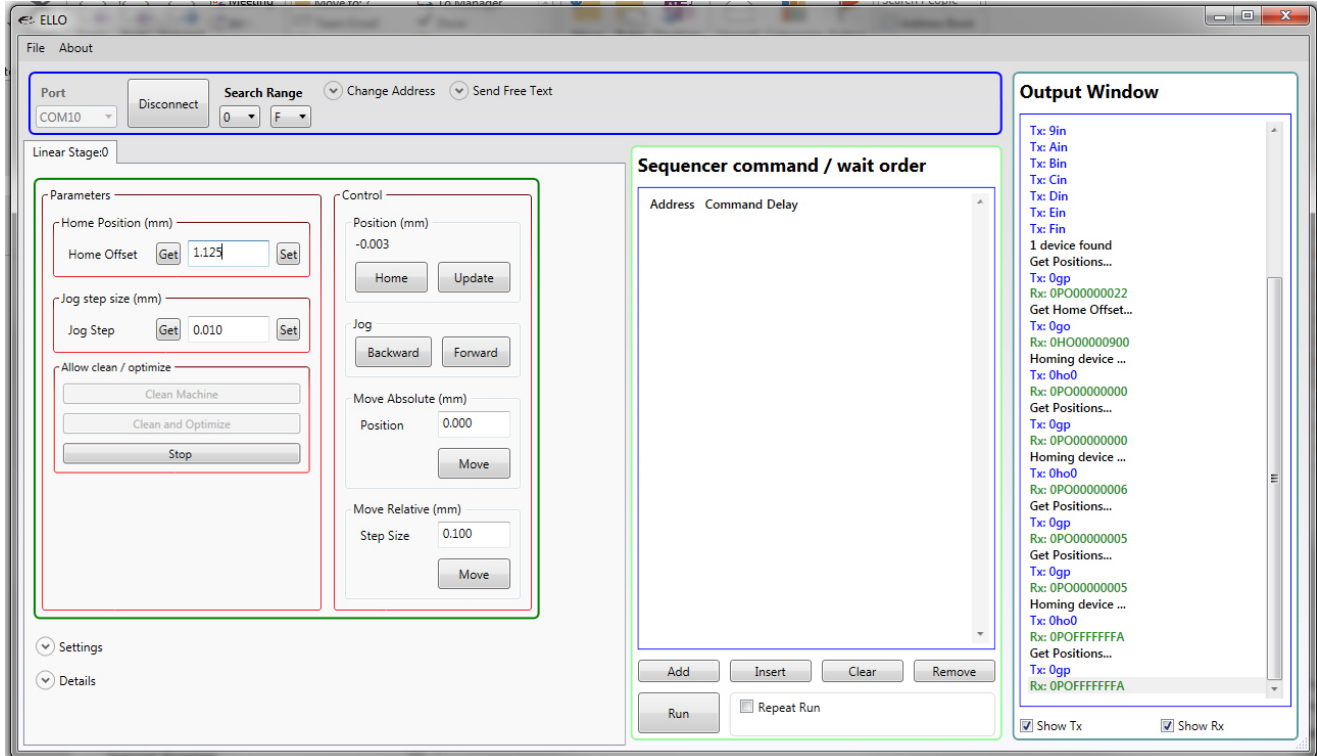

### 4.2.3 Communications Protocol

Custom move applications can be written in languages such as C# and C++.

The communication bus allows multi-drop communication with speeds at 9600 baud, 8 bit data length, 1 stop bit, no parity.

Protocol data is sent in ASCII HEX format, while module addresses and commands are mnemonic character (no package length is sent). Modules are addressable (default address is "0") and addresses can be changed and/or saved using a set of commands. Lower case commands are sent by user while upper case commands are replies by the module.

Please refer to the communications protocol manual for more detail about commands and data packet formats.

### 4.2.4 Connecting Multiple Devices

When a device is first connected to the PC, it is assigned the default address '0'. The software can run multiple devices, however before more than one device can be recognized, each device must be assigned a unique address. See below for a brief overview; detailed instructions are contained in the help file supplied with the software.

Connect the first device to the PC USB port, then run the Elliptec software and load the device.

Change the address of the first device.

Connect the next device to the first device.

Change the address of the second device.

Multiple devices can be controlled individually, either via a remote handset connected to each device, via the Elliptec software or by a third part application written using the messages detailed in the protocol document.

### 4.2.5 Controlling the stage without the Handset

**Caution**

During normal operation each motor is protected with a time out of 2.5 seconds to prevent overheating. Do not override this protection or drive the motors continuously.

In the absence of the handset, the stage is controlled via digital lines: forward, backward and mode (J1 pins 7, 6 and 5) by shorting the corresponding line to ground (pin 1).

When the stage is moving, the open drain IN MOTION digital line (pin 4) is driven low (active low) to confirm movement. The IN MOTION line goes high (inactive) when the move is completed or the maximum time-out (2 seconds) is reached.

**Warning**

Do not exceed the voltage and current ratings stated in Figure 6.

Do not reverse polarity.

**Connector J1 Pin Out**

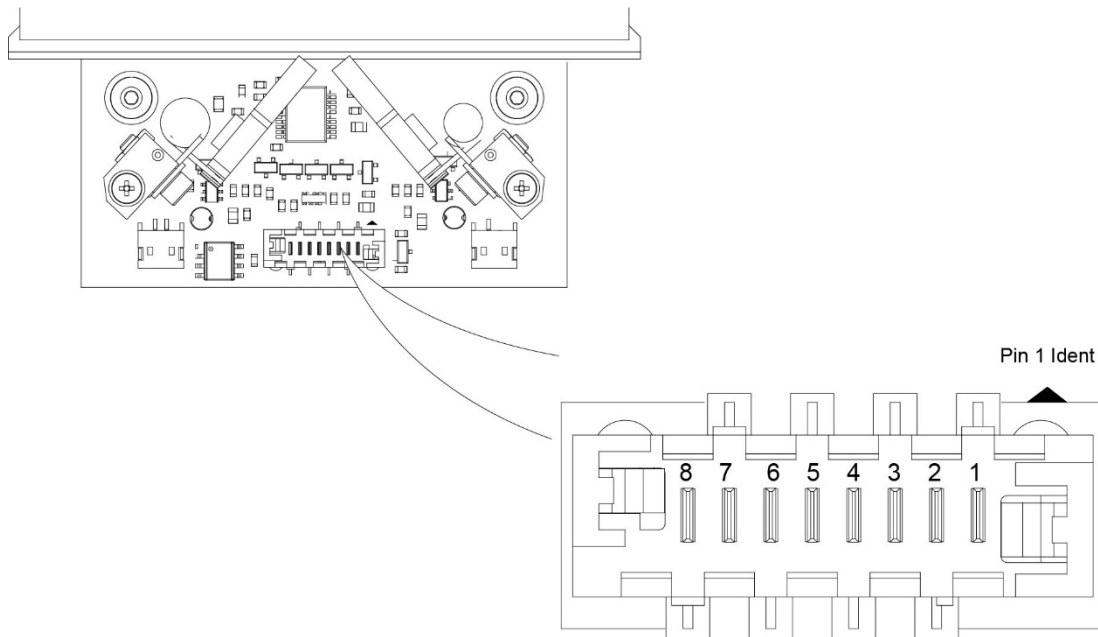

PIN	TYPE	FUNCTION
1	PWR	Ground
2	OUT	ODTX - Open Drain Transmit 3.3 V TTL RS232
3	IN	RX Receive - 3.3 V TTL RS232
4	OUT	In Motion, Open Drain Active Low Max 5 mA
5	IN	JOG/Mode, Active Low Max 5 V
6	IN	BW Backward , Active Low Max 5 V
7	IN	FW Forward, Active Low Max 5 V
8	PWR	VCC +5 V +/-10% 900 mA

**Connector model number MOLEX 90814-0808 Farnell order code 1518211**

**Mating connector model number MOLEX 90327-0308 Farnell order code 673160**

**Figure 5 Connector J1 Pin Out Details**

### 4.3 Frequency Search

Due to load, build tolerances and other mechanical variances, the default resonating frequency of a particular motor may not be that which delivers best performance. A frequency search can be performed using the Main GUI panel in the ELLO software, or by using the serial communication line (SEARCHFREQ\_MOTORX message), which offers a way to optimize the operating frequencies for backward and forward movement.

This search can also be performed manually by restoring the factory settings as described in [section 4.5](#).

### 4.4 Periodic Cycling of Devices Over Full Range of Travel

**Caution**

Periodically, devices should be moved over the full range of travel, from one end to the other. This will help minimize the buildup of debris on the track and will prevent the motors digging a groove over the most used area of contact. Typically, a travel cycle should be performed every 10K operations.

### 4.5 Restoring Factory Settings

Factory settings can be restored during the startup (calibration) test as follows:

1. Remove power from the stage and disconnect the USB cable.
2. Press and hold the BW button (do not release until item 5).
3. POWER UP and reconnect the USB cable.
4. WAIT for red led to switch on.
5. Release BW. The unit will reboot and load the default factory values.

### 4.6 Simultaneous Movement of Devices

If more than one device is connected to the comms bus, movement of the devices can be synchronized. This can be achieved either by using the handset, or by software. See the protocol document for details on how to use the 'ga' message to synchronize moves. If using the handset, synchronized movement is hard wired, so if multiple devices are connected, pressing the FWD or BWD buttons will move all devices.

## Chapter 5 Troubleshooting and FAQ

### 5.1 Frequently Asked Questions

#### Stage is moving back and forth after power up

If the digital line “bw” is driven low before powering up the stage, the module will go into calibration mode. Remove power to exit calibration mode. Keep line tight up to 3.3 V or 5 V rail during power up or use a serial communication line instead.

#### Stage not moving

Check power supply lines ratings (polarity, voltage drop or range, available current) or reduce cable length.

Check module is not in boot loader mode (power cycle the module to exit boot loader) consumption must be higher than 36 mA at 5 V.

#### Stage does not complete homing commands

Power cycle the unit.

Perform a frequency search on both motors.

#### Stage switching time increased / max load decreased

Check power supply voltage provided on J1 connector, increase voltage within specified limits if voltage drop along cable goes below 5 V during system operation.

Clean the moving surfaces. To avoid grease contamination, do not touch the moving parts.

Temperature change may affect the stage performance. Using the software to perform a frequency search will compensate frequency as needed (required current could reach 1.2 A during frequency search, use an additional 5 V 2 A power supply (TPS101) and a USB connection).

Integrators should search for optimal frequency on every power up sequence (commands “s1”, “s2” see ELL protocol document).

#### Restoring the factory (default) settings

Factory settings can be restored at any time – see Section 4.5.

#### Motor optimization does not work

The optimization may fail if the device is damaged, if the load is heavily unbalanced or changed in position during the optimization, or if the power supply is not stable.

##### Note

Do not run more than one device optimization at the same time on the same bus and power supply.

The current drawn can overload the power supply. Allow 20 minutes of cool down between consecutive optimizations on the same device.

If the optimization fails, the device will try to reload the previous settings. If this reload fails, perform a frequency search (see section 4.3) to reload the settings.

#### The unit is not responding after power up

During the power up sequence, if the user holds down the JOG, BW and FW lines to ground, the module will go into a boot loader (firmware update) mode.

Power cycle the unit again without pressing the 3 buttons at the same time to exit from the boot loader mode.

### The device is not responding during cleaning or optimization

This is normal.

The cleaning and the optimization routines block a device and the associated communication bus for several minutes. When one of these routines is initiated, the bus is unavailable until the routine is completed, and the device replies busy 'OGS09' to all commands except the stop command '0st' (for a unit at address 0). The stop request can take up to 5 seconds to abort the operation.

During these routines, the unit may increase in temperature by several degrees. Because of this inherent temperature increase, consecutive cleaning and optimization routines should be avoided.

After optimization or cleaning, allow a 20 min cool down period before use.

### Product lifetime

ELL20 product lifetime is restricted by the wearing of moving surfaces and the motor contact as motion is started (due to resonance build up) and performed (due to friction), and is expressed in km travelled. Lifetime will depend on several factors (e.g. load, number of homing operations, number of frequency searches etc.) and users must take into account all these factors when considering life time. For example, homing requires more travel than a simple motion, and a frequency search may not generate any motion at all, but still energizes the motors fully.

The unit is not designed for continuous operation. Users should aim for a duty cycle of less than 40% wherever possible, and never exceed a duty cycle of 60% for longer than a few seconds.

The minimum lifetime is 100 km.

### Handling



#### Warning

The equipment is susceptible to damage from electrostatic discharge. When handling the device, anti-static precautions must be taken and suitable discharge appliances must be worn.



The stage and interface board are robust to general handling. To ensure reliable operation, keep the surface of the plastic track contacted by the motors free of oils, dirt, and dust. It is not necessary to wear gloves while handling the stage, but avoid touching the track to keep it free of oils from fingerprints. If it is necessary to clean the track, it may be wiped with isopropyl alcohol or mineral spirits (white spirit). Do not use acetone, as this solvent will damage the plastic track.

## 5.2 Notes on Making a Picoflex Cable for Use when Daisy Chaining Devices

The multi-drop communications bus offers the option of connecting the stage to a hybrid network of up to 16 Elliptec resonant motor products and controlling the connected units with a device such as a microprocessor. When multiple units are connected to the same interface board, all can be controlled simultaneously using either the software or the buttons on the interface board.

When making a cable to operate multiple devices it is important to observe the correct pin orientation. The following procedure offers guidance in making such a cable.

1. Gather together the parts required.
  - a) Ribbon cable 3M 3365/08-100 (Farnell 2064465xxxx).
  - b) Female crimped connectors as required - model number MOLEX 90327-0308 (Farnell order code 673160) (Qty 1 female connector above is shipped with each stage unit).
  - c) Suitable screwdriver and scissors or other cutting tool.



2. Orientate the first connector correctly to mate with the connector on the stage, then arrange the ribbon cable as shown with the red wire aligned with pin 1 (identified on the pcb by a small triangle). Slide the connector onto the ribbon cable as shown.

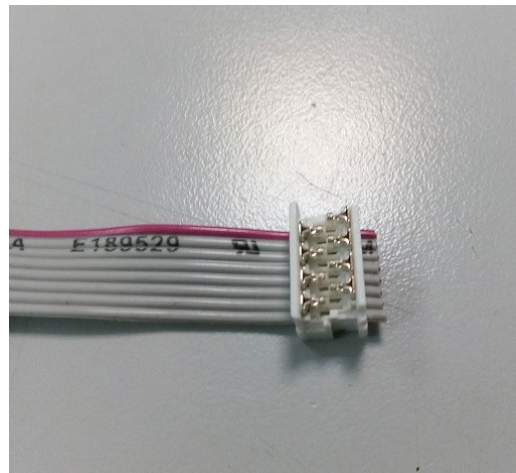
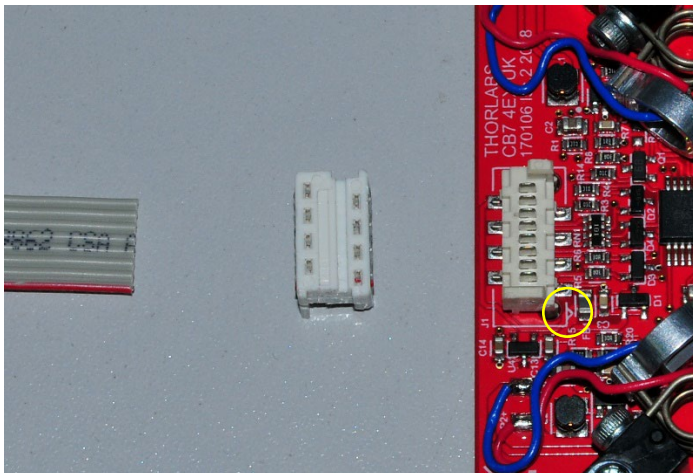



- Using a screwdriver or other suitable tool, push down the crimp of each pin to make connection with the ribbon cable.

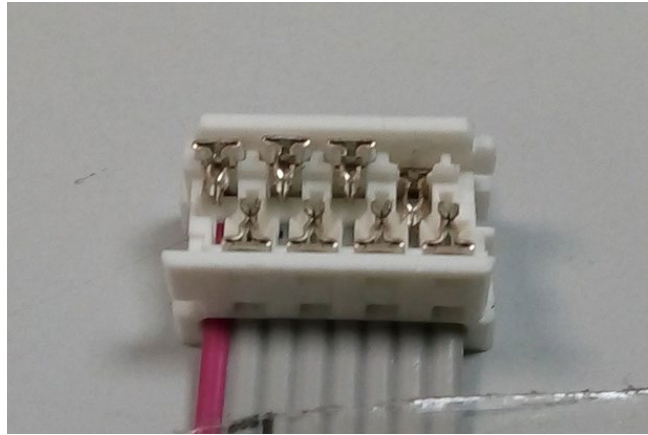
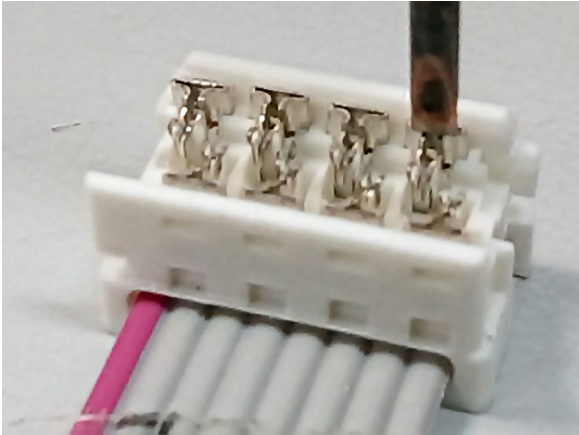

- If other connectors are required they should be fitted at this point. Slide each connector onto the cable, paying attention to the orientation as shown below, then crimp as detailed in step (3).

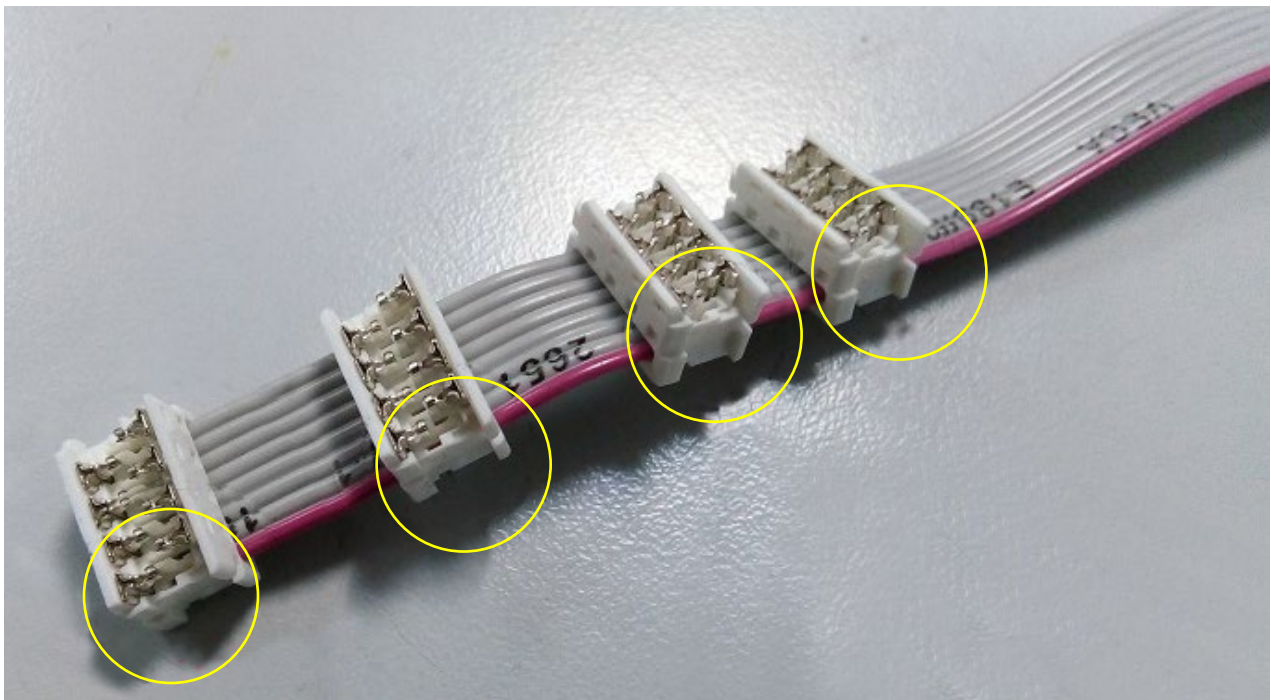

- Fit the terminating connector which will mate with the interface board, taking care to orientate the connector correctly, and align the cable red wire with pin 1 as detailed in step (2).

## Chapter 6 Specifications

Parameter	Value
<b>Performance <sup>a</sup></b>	
Travel	60.0 mm (2.4")
Positioning Accuracy	50 $\mu$ m
Homing Accuracy	20 $\mu$ m
Repeatability (with 100 g Load)	20 $\mu$ m
Max Velocity (No Load)	90 mm/s
Max Acceleration (No Load)	6.0 m/s/s
Minimum Motor Holding Force (Both Motors Engaged)	1 N
Vertical Straightness <sup>b</sup>	13.0 $\mu$ m
Horizontal Straightness <sup>b</sup>	13.0 $\mu$ m
Pitch (Over Full Travel Range)	1.5 mrad
Yaw (Over Full Travel Range)	1.5 mrad
Full Scale Non Linearity Error	<120 $\mu$ m
Encoder Resolution	0.98 $\mu$ m
Velocity Compensation (No Load) <sup>c</sup>	60 to 100%
Max Total Load	200 g
Minimum Lifetime <sup>d</sup>	100 km of travel
<b>Electrical</b>	
Motor Type	Elliptec Resonant Piezo
DC Voltage Input	4.5 to 5.5 V
Typical Current Consumption During Movement (No Load)	0.90 A
Typical Standby Current	0.07 A

### Notes

- a. Performance specifications are given for the case when the linear stage is mounted as recommended in the Section 2.3.
- b. Deviation from the Ideal Path, Referenced to a Theoretical Straight Line
- c. The velocity of the stage can be adjusted to a value equal to or greater than 60% of the maximum velocity through use of the ASCII message calls described in the protocol document.
- d. The linear stage is not designed for continuous operation.

## Specifications Cont...

Communications	
Bus <sup>f</sup>	Multi-Drop 3.3 V/5 V TTL RS232
Connector on Linear Stage Board	Picoflex®
Connectors on Interface Board	Picoflex® Micro-B USB 5 VDC Power: [For Plug with Ø5.5 mm OD (Ground) and Ø2.1 mm ID (+5 V)]
Speed	9600 baud
Data Length	8 bit (1 Stop Bit, No Parity)
Protocol Data Format	ASCII HEX
Module Address and Command Format	Mnemonic Character
8-Conductor Ribbon Cable Length (Supplied)	250 mm
8-Conductor Ribbon Cable Length (Maximum)	3 m
General	
Location	Indoor Use Only
Operating Temperature Range	15 to 40 °C (59 to 104 °F)
Maximum Altitude	2000 m
Maximum Humidity	Less than 80% RH (Non-condensing) at 31 °C
Dimensions At Center Travel, with Bracket Fitted	102.3 x 67.0 x 18.4 mm (4.03" x 2.64" x 0.73")
Dimensions At End of Travel, with Bracket Fitted	114.0 x 67.0 x 18.4 mm (4.49" x 2.64" x 0.73")
Dimensions of Interface Board	66.0 x 32.0 x 12.5 mm (2.6" x 1.26" x 0.49")
Weight (Stage plus Bracket)	Metric 0.104 kg, Imperial 0.229 lb
Weight (Stage Only)	Metric 0.069 kg, Imperial 0.152 lb

## Note

f. Use two 10 kΩ pull-up resistors in multi-drop mode for RX/TX

## Chapter 7 Regulatory

### 7.1 Declarations of Conformity

#### 7.1.1 For Customers in Europe

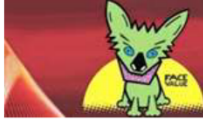

# THORLABS

www.thorlabs.com

### EU Declaration of Conformity

in accordance with EN ISO 17050-1:2010

We: Thorlabs Ltd.  
 Of: 1 St. Thomas Place, Ely, CB7 4EX, United Kingdom

*in accordance with the following Directive(s):*

2006/42/EC	Machinery Directive (MD)
2014/30/EU	Electromagnetic Compatibility (EMC) Directive
2011/65/EU	Restriction of Use of Certain Hazardous Substances (RoHS)

*hereby declare that:*

Model: **ELL20/M**

Equipment: **60 mm Linear Translation Stage**

*is in conformity with the applicable requirements of the following documents:*

EN ISO 12100	Safety of Machinery. General Principles for Design. Risk Assessment and Risk Reduction	2010
EN 61326-1	Electrical Equipment for Measurement, Control and Laboratory Use - EMC Requirements	2013

*and which, issued under the sole responsibility of Thorlabs, is in conformity with Directive 2011/65/EU of the European Parliament and of the Council of 8th June 2011 on the restriction of the use of certain hazardous substances in electrical and electronic equipment, for the reason stated below:*

is exempt from the requirements of the Directive because its intended application is excluded pursuant to Annex III or Annex IV of the Directive. Exempt 7 C I.

*I hereby declare that the equipment named has been designed to comply with the relevant sections of the above referenced specifications, and complies with all applicable Essential Requirements of the Directives.*

Signed: 

On: 20 February 2019

Name: Keith Dhese  
Position: General Manager



EDC - ELL20/M -2019-02-20

#### 7.1.2 For Customers in the USA

This equipment has been tested and found to comply with the limits for a Class A digital device, pursuant to part 15 of the FCC rules. These limits are designed to provide reasonable protection against harmful interference when the equipment is operated in a commercial environment. This equipment generates, uses and can radiate radio frequency energy and, if not installed and used in accordance with the instruction manual, may cause harmful interference to radio communications. Operation of this equipment in a residential area is likely to cause harmful interference in which case the user will be required to correct the interference at his own expense.

Changes or modifications not expressly approved by the company could void the user's authority to operate the equipment.

## Chapter 8 Thorlabs Worldwide Contacts

For technical support or sales inquiries, please visit us at [www.thorlabs.com/contact](http://www.thorlabs.com/contact) for our most up-to-date contact information.



### USA, Canada, and South America

Thorlabs, Inc.  
sales@thorlabs.com  
techsupport@thorlabs.com

### Europe

Thorlabs GmbH  
europe@thorlabs.com

### France

Thorlabs SAS  
sales.fr@thorlabs.com

### Japan

Thorlabs Japan, Inc.  
sales@thorlabs.jp

### UK and Ireland

Thorlabs Ltd.  
sales.uk@thorlabs.com  
techsupport.uk@thorlabs.com

### Scandinavia

Thorlabs Sweden AB  
scandinavia@thorlabs.com

### Brazil

Thorlabs Vendas de Fotônicos Ltda.  
brasil@thorlabs.com

### China

Thorlabs China  
chinasales@thorlabs.com

Thorlabs verifies our compliance with the WEEE (Waste Electrical and Electronic Equipment) directive of the European Community and the corresponding national laws. Accordingly, all end users in the EC may return “end of life” Annex I category electrical and electronic equipment sold after August 13, 2005 to Thorlabs, without incurring disposal charges. Eligible units are marked with the crossed out “wheelie bin” logo (see right), were sold to and are currently owned by a company or institute within the EC, and are not disassembled or contaminated. Contact Thorlabs for more information. Waste treatment is your own responsibility. “End of life” units must be returned to Thorlabs or handed to a company specializing in waste recovery. Do not dispose of the unit in a litter bin or at a public waste disposal site.

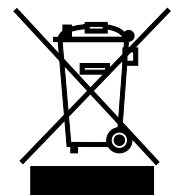

**Annex I**



**THORLABS**  
[www.thorlabs.com](http://www.thorlabs.com)

---