

F9J "	89G7 F-DHC B.	B5A 9#85H9.

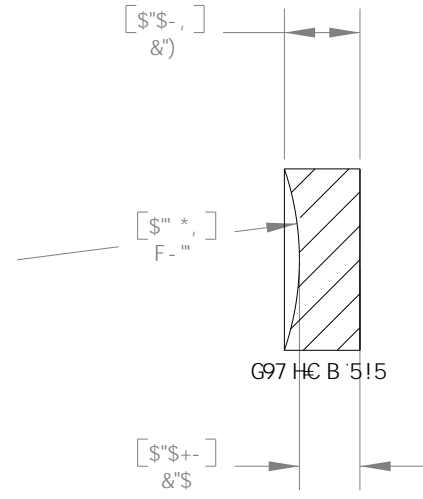
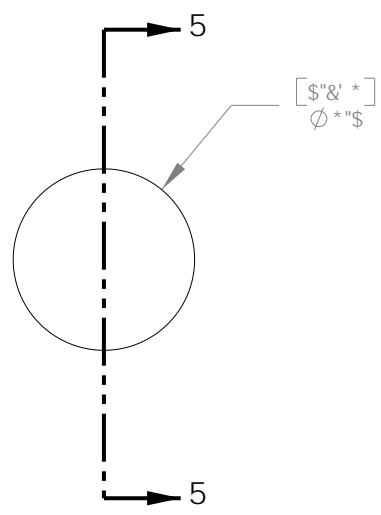

89G≠ B K 5J 9@9B; Hk. ' * ' ' ba
 G7 F5H7 <#8 ÷ . (\$ # & \$
 8-5A 9H9F 'HC @9F5B7 9. Z '\$ '\$\$ a a # '\$ % \$ a a
 7 @5F '5D9F5H F9. 2- \$i
 7 9BHF5HC B. ' ' 5F7 'A B"
 5 @5F '7 C 5HB; G'5F9'6FC 5865B8 '5F '
 7 C 5HB; GK #k FO\$") i ' C J 9F 'Hk 99BHF9F5B; 9
 5H\$S-B7 -8 9B7 9"
 7 C 5HB; . '665F '\$) \$ba ! '% '\$\$ba
 : C 75 @9B; Hk. ! % " \$ a
 657 ? : C 75 @9B; Hk. ! % " a a
 b1 %)) \$, &

HC @F5B7 9G	B5A 9	85H9
1 B @9GC H: 9FK @9 GD97 ≠ 98.	8F5K B	65; (#& #&\$ \$*
8-A 9BGC BG5F9-B 'B7 <9G	9B; '5DDF"	HC (#& #&\$ \$*
@B95F HC @F5B7 9G	A: ; '5DDF"	HC (#& #&\$ \$*
... Hk C D @57 9897-A 5@ ± '\$ '\$ \$	DFC DF-9'6FM5B8 7 C B: -8 9B H5@	
... Hk F99 D @57 9897-A 5@ ± '\$ '\$ \$	Hk-9 B: CFA 5HC B 7 C B H5-B 98-B Hk-6	
5B: 1 @5F. ± ' \$ π	8F5K B: '6H-9GC @DFC D9F HMC:	
GI F: 57 9: -B G< . ' & A -7 FC -B7 <9G	Hk C F @56Gz-B7 " '5B MF9DFC 8I 7 HC B	
D5F5 @9@CA. '\$ '\$ \$ &	-B D5FHC F 5G5 K <C @K #k C I H	
: @5B 9CG '\$ '\$ \$ &	Hk-9 K F #H8 D9FA 4GC B C:	
GF 5 ≠ <HB 9CG '\$ '\$ \$ &	Hk C F @56Gz-B7 " 4DFC <-6+98"	
7 C B7 9B HF -7 #M '\$ '\$ \$ &		
D9F D9B 8-71 @5F #M '\$ '\$ \$ &		
Hk F95 8. 7 @5GG &: #		

Hk C F @5 6G 'B 7 "		DC '6C L' **
		B 9K HC B B >
H# @.		
D @BC '7 C B 75 J 9 @BGZ !% "\$a a 'X1*" "\$a a '		
A 5H9F 5@	6?+	G#9 5 F9J " 6
G7 5 @ (. %		G< 99H% C : %
8K ; " "BC "	(+ , !9\$ %	D5FHBC " @ %\$ ') !7