

- NOTES:**
- FRONT VIEW DIMENSIONS VALID WHEN AT FREE STATE AND POWERED OFF (OR WHEN AT 0V).
 - REFER TO INSTRUCTION MANUAL FOR GEOMETRY DETAILS IN OPERATION.

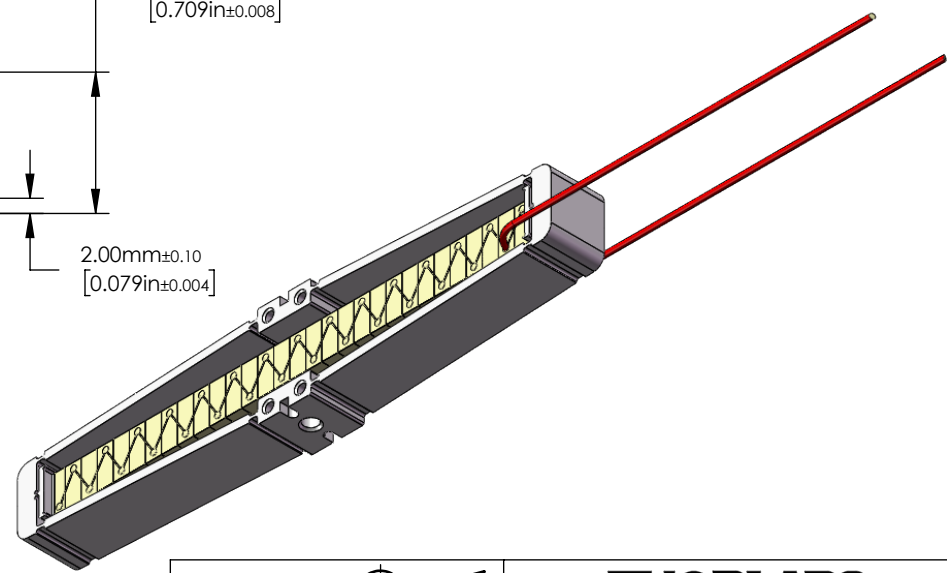
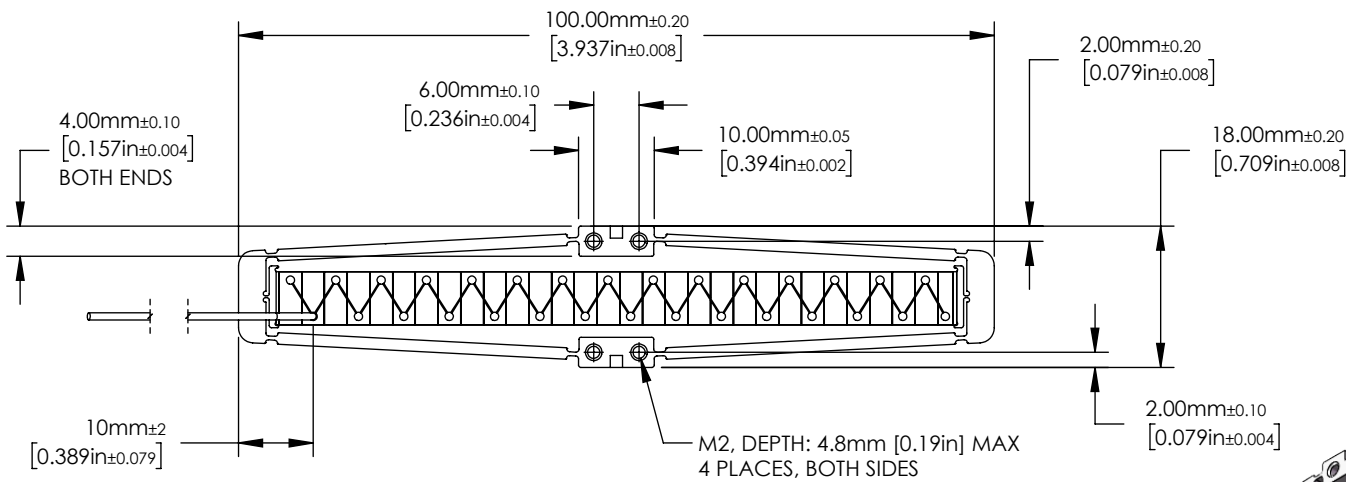
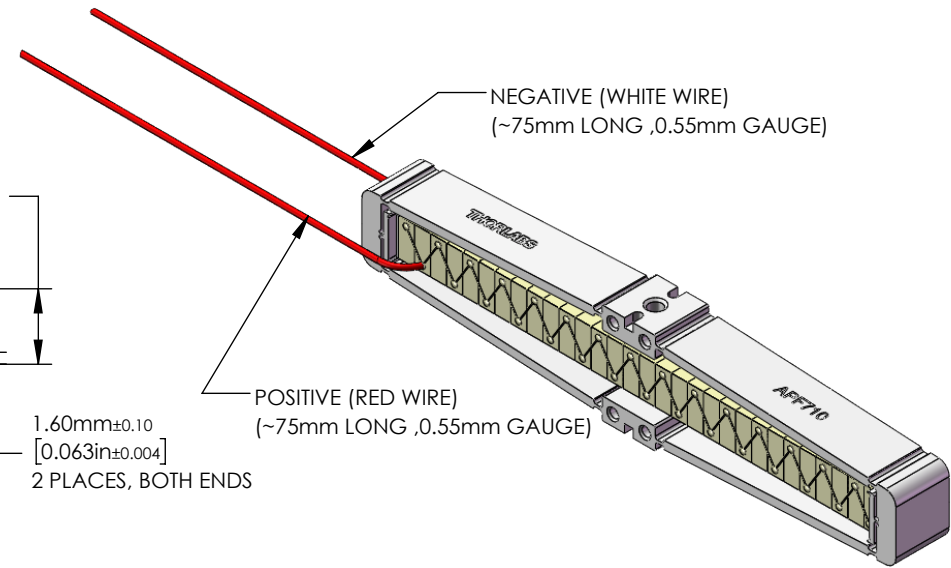
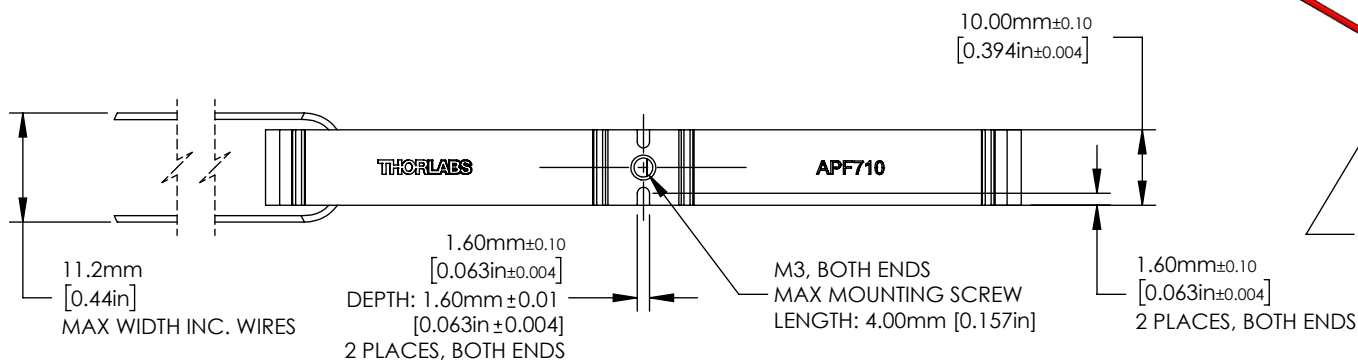

FOR INFORMATION ONLY
NOT FOR MANUFACTURING PURPOSES

DRAWING PROJECTION				 www.thorlabs.com	
NAME	DATE	AMPLIFIED PIEZO FLEXURE ACTUATOR, 7 SERIES, 1500um TRAVEL			
DRAWN	F.B.	24/SEP/19	MATERIAL		REV B
APPROVAL	D.J.G.	24/SEP/19	N/A		
COPYRIGHT © 2019 BY THORLABS					
VALUES IN PARENTHESIS ARE CALCULATED AND MAY CONTAIN ROUND OFF ERRORS					
ITEM #		APF710		APPROX WEIGHT	
				0.07 kg	