

F9J "	89G7 F-DHC B.	B5A 9#85H9.

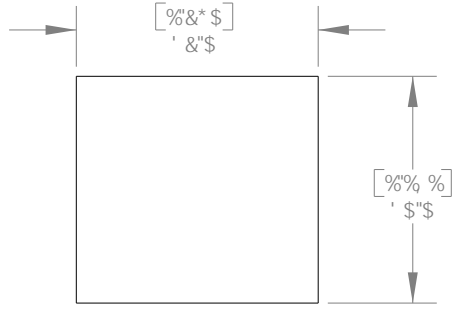
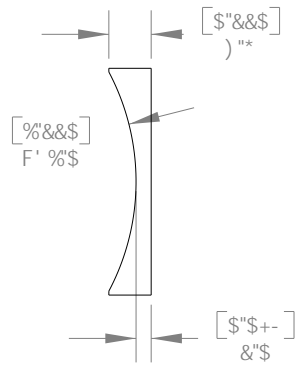
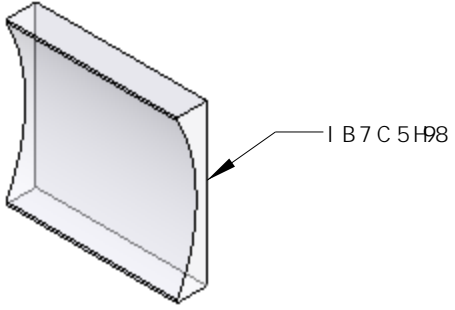

GD97 ÷ ÷ 7 5HC BG
 : C 7 5 @ @ B ; H k f a a t ! * \$
 89G ÷ B ' K 5 J 9 @ B ; H k . ') , + " * b a
 G 7 F 5 H 7 < # 8 ÷ . * \$ # (\$
 @ B ; H k H C @ F 5 B 7 9 . Z \$ " \$ \$ # \$ " % \$ a a
 K - 8 H k H C @ F 5 B 7 9 . Z \$ " \$ \$ # \$ " % \$ a a
 7 @ 5 F ' 5 D 9 F 5 H F 9 . ' 2 - \$ i
 7 9 B H F 5 H C B .
 " " : C F Z @ \$ a a . ' @ U f W a j b
 " " : C F Z Z) \$ a a . ' @ U f W a j b
 7 9 B H F H k ÷ ? B 9 G G H C @ F 5 B 7 9 . ' - \$ " & a a

BCH9.
 : CF ÷ B : CFA 5HC B ' CB @ M
 BCH : CF A 5BI : 57H F ÷ B ; "

HC @ F 5 B 7 9 G	B5A 9	85H9
I B @ 9 G G C H : 9 F K @ 9 G D 9 7 ÷ 9 8 .	8 F 5 K B	5 D
8 - A 9 B G C B G 5 F 9 - B ' A - @ A 9 F F G	9 B ; ' 5 D D F "	H C
... 5 B 8 - B 7 < 9 G	A : ; ' 5 D D F "	H C
@ B 9 5 F H C @ F 5 B 7 9 G		
... C B 9 D @ 5 7 9 8 9 7 - A 5 @ ± \$ " &	D F C D F - 9 6 F M 5 B 8 7 C B : - 8 9 B H 5 @	
... H K C D @ 5 7 9 8 9 7 - A 5 @ ± \$ " & (H k 9 B : C F A 5 H C B 7 C B H 5 B 9 8 - B H k 6	
5 B : 1 @ F . ± ' \$ π "	8 F 5 K B : ' 6 H k 9 G C @ 9 D F C D 9 F H M C :	
	H k C F @ 5 6 G z B 7 " " 5 B M F 9 D F C 8 I 7 H C B	
	B D 5 F H C F 5 G 5 K < C @ K H k C I H	
	H k 9 K F H 9 B D 9 F A 6 G C B C :	
	H k C F @ 5 6 G z B 7 " " 6 D F C < 6 + 9 8 "	

H k C F @ 5 6 G z B 7 "	DC ' 6 C L ' ' * *
	B 9 K H C B ' B >
H # @ .	
D @ 5 B C ! 7 C B 7 5 J 9 ' 7 M @ B 8 F ÷ 5 @ @ 9 B G 9 G	
A 5 H 9 F 5 @	G 4 9 F 9 J "
6 ? +	5 5
G 7 5 @ . % %	G < 9 9 H % C : %
8 K ; " " B C "	D 5 F H B C "
(\$ (' ! 9 \$ %	@ % -) @ %