

F9J "	89G7 F-DHC B.	B5A 9#85H9.

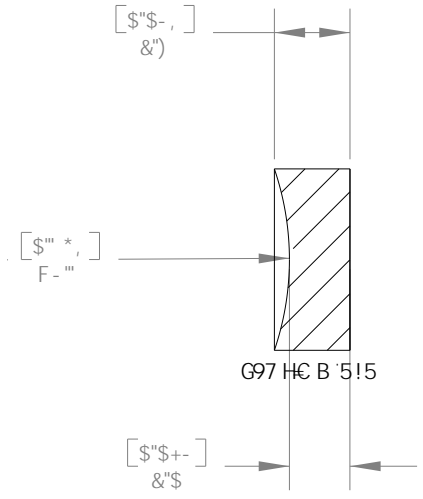
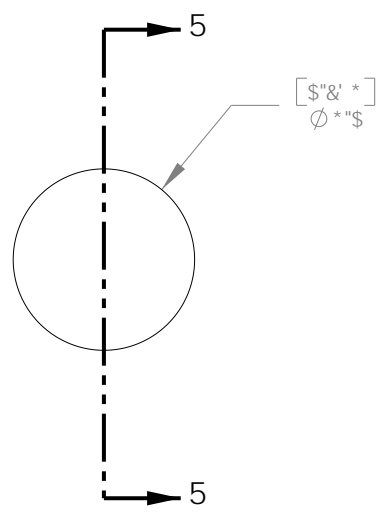

89G÷ B K 5J 9@9B; Hk. ' * ' ' ba
 G7 F 5H7 <#8 ÷ . (\$ # & \$
 8-5A 9H9F HC @9F 5B 7 9. Z \$ " \$ \$ a a # \$ " % \$ a a
 7 @5F '5D9F 5H F 9. 2- \$ i
 7 9BHF 5HC B. ' ' 5F 7 'A B"
 5 @5F '7 C 5HB; G'5F 9'6FC 5865B8 '5F '
 7 C 5HB; GK #k FO\$") i ' C J 9F 'Hk 99BHF 9F5B; 9
 5H\$S 'B 7 -8 9B 7 9"
 7 C 5HB; . '1 B 7 C 5H98
 : C 7 5 @ @9B; Hk. ! % " \$ a a
 657 ? : C 7 5 @ @9B; Hk. ! % " " a a
 b1 %) % \$, &

HC @F 5B 7 9G	B5A 9	85H9
I B @9GC H: 9FK @9 GD97 ÷ 98.	8F5K B	HC
8-A 9B GC BG 5F 9-B 'B 7 < 9G	9B; '5DDF"	HC
@B 95F HC @F 5B 7 9G	A: ; '5DDF"	HC
... Hk C D @5 7 9 8 97-A 5 @ ± \$ \$ % \$		
... Hk F 99 D @5 7 9 8 97-A 5 @ ± \$ \$ % \$		
5B: 1 @5 F. ± ' \$ π	DFC DF-9H 6FM 5B 8 7 C B: -8 9B H 5 @	
GI F: 5 7 9: -B G< . ' & A - 7 FC -B 7 < 9G	Hk-9 B: CFA 5HC B 7 C B H 5-B 98 -B Hk-G	
D5F 5 @ @9 CA. '\$ \$ \$ &	8F5K B: 'G H-9 GC @9 DFC D9F HMC:	
: @5 HB 9CG '\$ \$ \$ &	Hk C F @5 6Gz-B 7 " '5 B MF 9DFC 8I 7 HC B	
GF 5 ÷ < HB 9CG '\$ \$ \$ &	-B D5F HC F 5G 5 K < C @K #k C I H	
7 C B 7 9B HF - 7 H M '\$ \$ \$ &	Hk-9 K F #H 9B D9FA 4GC B C:	
D9F D9B 8-7 1 @5 F #M '\$ \$ \$ &	Hk C F @5 6Gz-B 7 " 'G DFC < -6 +H 8"	
Hk F 95 8. 7 @5 GG &: #		

Hk C F @5 6Gz-B 7 "		DC '6C L' **
		B 9K HC B B >
H# @.		
D @5 BC '7 C B 7 5 J 9 @BG Z ! % " \$ a a ' X 1 * " \$ a a '		
A 5H9F 5 @	6? +	G#9 F9J "
		5 6
G< 99H% C: %		
8K ; " " BC "	D5FH BC "	
' (& (! 9 \$ %	@ % \$ ')	