

F9J "	89G7 F-DHC B.	B5A 9#85H9.

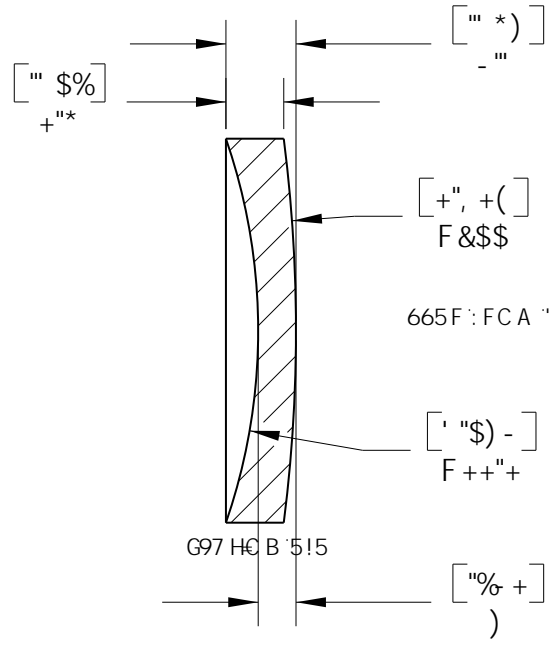
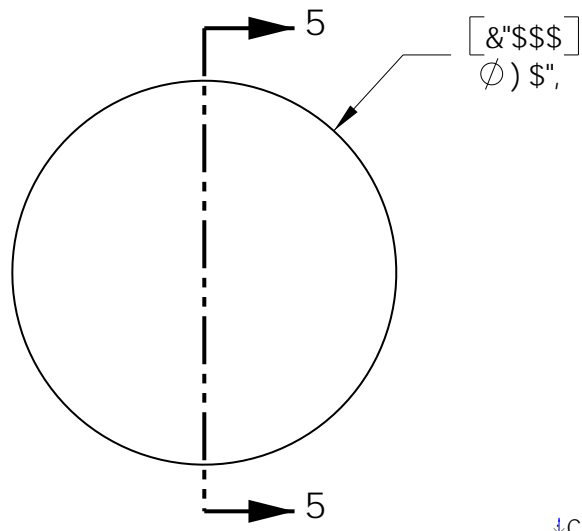

\*C 75@@B; Hk. !&) \$"\$a a  
657?: C 75@ !&(+ "- a a  
B 89L. %)%) '4 \*' ' ba  
89G= B 'K 5J 9@B; Hk. ' \*' ' ba  
G7 F5H7 <#8 = '( \$&\$  
8-5A 9HF 'HC @F 5B 79. Ž \$"\$a a # \$"\$a a  
7 @95F '5D9FH F9. O- \$i  
7 9BHF 5HC B. ' '5F7 'A B  
7 9BHF 'Hk-? ?B9GG'HC @F 5B 79. '- \$"\$a a  
7 <5A : 9F '\$&\$a a '5H() \$'5@@G<5FD'98; 9G  
98; 9Hk-? ?B9GG'5GGI A B; 'G<5FD'98; 9  
5B8; 9B '69. C F97 <5A : 9F

**BCH9.**  
: CF 'B: CFA 5HC B 'CB@M  
BCH: CF 'A 5BI : 57H F-B;  
5@I B+G; 9B 'B 'A @A 9HFG

<b>HC@F5B79G</b>	B5A 9	85H9
1 B@GGCH: 9FK @9 GD97 =98.	8F5K B	5D )#&#&\$*\$
8-A 9BGCBG5F9-B 'B7<9G	9B: '5DDF"	HC )#&#&\$*\$
@B95F HC@F5B79G	A:: '5DDF"	HC )#&#&\$*\$
"Hk C D@579897-A 5@ ±\$"\$%	<b>DFC DF-96FM5B87CB: -98H5@</b>	
"Hk F99D@579897-A 5@ ±\$"\$%	Hk-9 B: CFA 5HC B 7 C B H5 B 98 B Hk-6	
5B: 1 @5F. '±' \$F"	8F5K B: '6Hk-9GC @DFC D9FHMC:	
GI F: 579: B-G<." &A =FC-B7<9G	Hk C F @56Gz-B7 "5BMF9DFC 8I 7 HC B	
D5F5 @9@CA. '\$\$\$&	B D5FHC F 5G5 K <C @K Hk C I H	
: @5B9CG '\$\$\$&	Hk-9K F #9B 'D9FA @GC B C:	
GF 5 = <H9CG '\$\$\$&	Hk C F @56Gz-B7 "6DFC <6+98"	
7 C B 7 9BHF =7 HM '\$\$\$&		
D9FD9B 8-71 @5F+M '\$\$\$&		
Hk F958. 7 @5GG&: #		

Hk C F @56Gz-B7 " DC '6CL" **	
B9K HC B 'B >	
H#H@.	
« ) \$"\$, a a '6?+ 'B9. 5HJ 9'A 9B-G7I G@9B G	
A 5H9F 5@	G#9 F9J "
6?+ž: fUXY '5	5 5
G7 5@. %%	G<99H% C: %
8K ; " "BC "	D5FH'BC "
(, , &19\$%	@%&* -!5