



## **LDC 500 Laser Diode Controller**

### **Instruction Manual**

Doc. Number 2136-D01

Rev D 7-9-2000

Copyright © 1997 **Thorlabs, Inc.**

435 Route 206N

Newton, NJ 07860 USA

Phone (973) 579-7227 FAX (973) 300-3600 [www.thorlabs.com](http://www.thorlabs.com)

## Table of content

	<b>Page</b>
1 General information .....	1-1
1.1 General description .....	1-1
1.2 Specifications .....	1-3
1.3 Ordering codes and accessories.....	1-4
1.4 Safety instructions .....	1-4
1.5 Warranty.....	1-5
2 Operation.....	2-1
2.1 Operating elements.....	2-1
2.2 Starting up .....	2-3
2.3 Operating the LDC 500.....	2-3
2.3.1 Setting the current limit "ILIM" .....	2-3
2.3.2 Selecting the laser diode polarity .....	2-4
2.3.3 Connecting laser diode and photodiode .....	2-4
2.3.4 Constant current mode (CONST I) .....	2-6
2.3.5 Constant power mode (CONST P).....	2-7
2.3.6 Calibrating the optical power display.....	2-9
2.3.7 Analog modulation of the laser diode .....	2-9
2.3.8 Control Output (Laser Current Monitor).....	2-10
3 Remote control.....	3-1
4 Service.....	4-1
4.1 Changing the line voltage.....	4-1
4.2 Replacing the main fuse .....	4-1
4.3 Adjusting Power Display decimal point.....	4-2
4.4 Maintenance and repair .....	4-2

# 1 General information

This manual contains the operating instructions for the LDC 500 laser diode controller by *Thorlabs*. In the first chapter you will find a general description of the units, technical specifications, a list of the available accessories, safety instructions and the warranty. Chapter 2 contains detailed operating instructions. Chapter 3 offers service information.

**We aim to develop and deliver optimally suited laser diode controllers for your application. To reach this goal, we need your suggestions on how our products can be further improved. Please let us know your proposals and criticisms. We and our distributors are at your disposal at any time.**

*Thorlabs, Inc.*

## 1.1 General description

The LDC 500 laser diode controller by *Thorlabs* is an extremely precise controller for laser diodes and LEDs. When used with the Thorlabs TEC2000 temperature controller, the laser current or the optical output power and the temperature of the connected laser diode can be precisely regulated. Thus the laser diode works as a stable optical transmitter.

The LDC 500 laser diode controller is well suited for:

- **Safe and simple operation of all laser diodes up to 0.5A**
- **Power stabilized light sources**
- **Wavelength tuning by controlling the current**
- **Wavelength modulation by current modulation**

To protect the laser diode against damage, the LDC 500 provides the following protection circuitry:

- **Softstart function**
- **Adjustable laser current limit**
- **Safety Interlock (open circuit monitoring of the laser diode mount connection)**
- **Electronic short-circuit for the laser diode**
- **Separate enable switch to turn the laser diode current on and off**
- **Monitoring LED for LASER ON mode**

Features:

- The LDC 500's front panel arrangement makes it easy to use.
- The operating levels (laser current, current limit, laser power, photodiode current), selected via a push button switch, are shown on an illuminated 4½-digit LCD display.
- The on/off delay and the soft start function protect the laser diode against undesired spikes.
- An independent limit for the laser current can be set with a 20-turn potentiometer, protecting the laser diode from operating errors.
- When the output is open, an electronic switch short-circuits the current output and no voltage is applied to the laser diode.

- When turned on, the LDC 500 is automatically in LASER DISABLED mode. The laser current can be switched on/off with a separate button on the front panel.
- Laser diodes and photodiodes are connected by a DB9 female connector located on the rear of the unit. The output for the laser diode and the input for the photodiode are bipolar, thereby allowing all polarities of commercially available laser diodes to be used with the LDC500.
- With a control signal at the output jack, an external LED can be driven to indicate LASER ON mode when the laser current is switched on.
- The laser current or the optical output power of the laser diode can be modulated via a modulation input at the rear of the unit.
- If an error occurs or the limit for the laser current is reached, the corresponding LED lights up and a beeper sounds a short warning signal.
- The installed line filter and the transformer shielding provide low ripple output.
- An internal fan provides cooling of the LDC 500 to protect the unit against overheating and high environmental temperatures. With free air circulation, a safe operation of the unit is guaranteed to at least 40 °C ambient temperature.
- Thorlabs has various mounts with built-in TEC temperature regulation and Bias-T inputs for RF modulation for a number of different laser packages that work directly with the LDC500.
- If a laser diode head and the corresponding cable (LDC500-CAB) by *Thorlabs* is used, damages caused by wrong connections are impossible.

## 1.2 Specifications

### Current control:

Control range (continuously adjustable)	0...±500 mA
Compliance voltage	> 4
Setting accuracy	±0.2 mA
Resolution	0.1 mA
Noise (10Hz...10MHz)	< 5 µA
Ripple (50Hz, rms)	< 2 µA
Transients	< 25 µA
Short term fluctuations (15 s)	< 20 µA
Temperature coefficient	≤ 50 ppm/°C
Drift (30 min, 0...10Hz)	< 50 µA

### Power control:

Photodiode current range	5 µA...2 mA	
Resolution photodiode current	0.1 µA	
Power range	20 mW/200 mW	jumper
Resolution optical power	1 µW/10 µW	jumper
Setting accuracy	±2 µA	
Drift	< 1 µA	

### Current limit:

Setting accuracy	±1.5 mA
Resolution	0.1 mA

### Analog Modulation - Control Input/Output:

Input impedance	10 kΩ
Bandwidth (current control)	DC...150 kHz
Laser current modulation coefficient	50 mA/V
Control Output (Laser Current Monitor)	0 to 10V (50mA/V)

### Connectors:

Laser diode, photodiode, LD ON signal, interlock	DB9 Female
Modulation input	BNC
Control output	BNC
Chassis ground	4 mm banana jack

### General data:

Line voltage	110 V ± 10%, 115 V ± 10%, 230 V ± 10%
Line frequency	50...60 Hz
Operating temperature	0...+40°C
Storage temperature	-40°C...+70°C
Warm-up time for rated accuracy	10 min
Weight	< 6.6 lb.
Dimensions (W x H x D)	5.8 x 2.8 x 12.5"

## 1.3 Ordering codes and accessories

The LDC500-CAB Interface Cable, a grounding contact type line cord, and the LDC500 Operating Manual are included with the LDC 500 (line cords for the LDC500-EC version are sold separately). The chart below shows the ordering codes of the units and the accessories currently available.

<u>Ordering-code</u>	<u>Short description</u>
LDC 500	Laser diode controller, current range 0 ... 100 mA / 2.5 V Ultra Low Noise
TCLDM9	<b>laser diode heads for different laser diode packages:</b> Temperature controlled laser diode head for 5.6mm and 9mm laser packages with RF modulation input. Includes built-in mounts for collimating optics and Thorlabs cage plate accessories that support a variety of mounting configurations.
TCLDM3	Same as TCLDM9 but for TO-3 laser packages.
LDC500-CAB	<b>Shielded cable:</b> Cable to connect the laser diode controller LDC 500 to a TCLDM9 or TCLDM3 Laser Diode Head

## 1.4 Safety instructions

It is important to read this chapter before initial operation to avoid device and connected circuit damage as well as endangering operators. These safety instructions must be adhered to strictly.

Only use the original line cord with grounding-contact type plug to connect the unit to the line. The unit is grounded via the ground conductor. To avoid electric shock hazard, the plug of the line cord must be connected to a correctly grounded power outlet. Grounding of the unit by the ground conductor of the line cord is necessary for safe operation. An interrupt of the ground conductor may cause extreme danger and injuries to persons by electric shock.

To ensure safe operation of the unit, always keep the ventilating louvers on both sides and on the rear of the unit free from obstruction of air flow.

The unit must not be operated in the presence of flammable gases or fumes.

The unit must not be opened during operation. Internal adjustment and replacement of parts must be done by qualified service personnel only. Parts must not be replaced during operation. Under certain conditions, dangerous voltages may exist even when the unit is disconnected from the line.

### **Attention:**

**All statements regarding safety of operation and technical data in this manual are only valid if the operation is carried through correctly. All connections to the load have to be made with shielded cables (unless noted otherwise). Thorlabs must consent in writing to any changes done to any components or to using components not provided by Thorlabs.**

**Mobile telephones and walky-talkies must not be used within the reach of three meters near this unit since the field intensities produced by this radio equipment then exceed the maximum allowed level per EN 50 082-1.**

## 1.5 Warranty

*Thorlabs* warrants material and production of the LDC 500 for 12 months from the date of shipment. During this period *Thorlabs* will either repair or replace parts which prove to be defective. For warranty repair or service, the unit must be returned to *Thorlabs*. *Thorlabs* warrants that the firmware, which is determined for this unit by *Thorlabs*, operates correctly if it is used according to our descriptions.

*Thorlabs* does not warranty that the unit will work without errors and interruptions or that this manual is free of errors. *Thorlabs* is not liable for consequential damages.

### **Limitation of warranty:**

This warranty shall not apply to defects resulting from inadequate treatment, interfacing, modification, misuse, operation outside the environmental specifications or unauthorized maintenance.

No other warranty is expressed or implied. *Thorlabs* specifically disclaims the implied warranty of merchantability and suitability for particular purposes.

*Thorlabs* reserves the right to change this manual and the technical specifications of the unit described herein at any time.

## 2 Operation

### 2.1 Operating elements

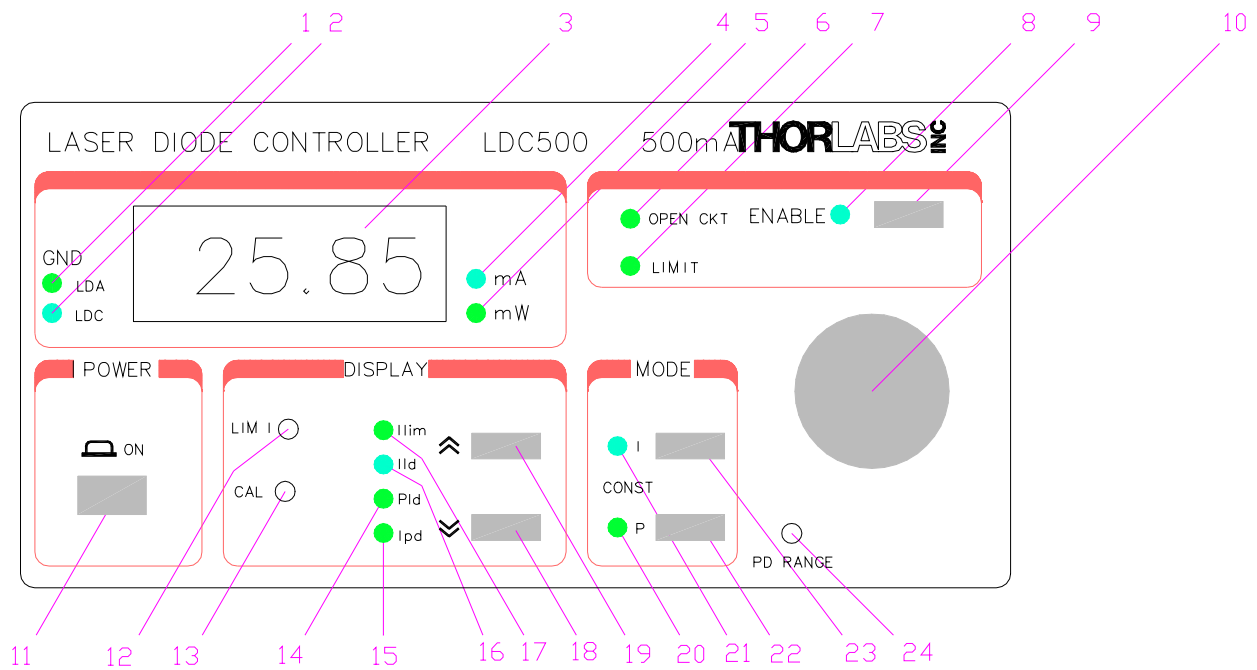
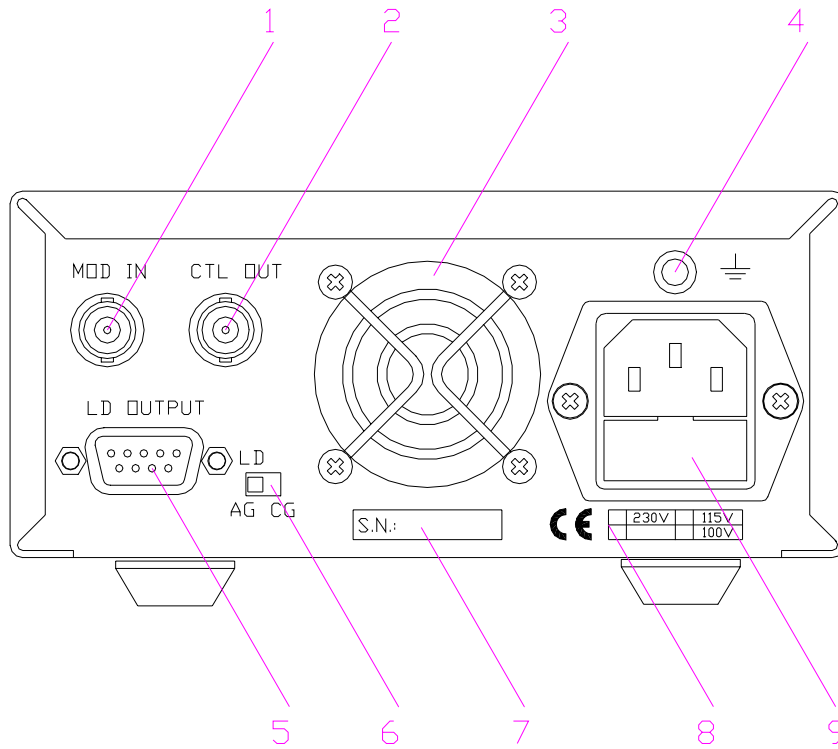

**Fig. 2.1** Displaying- and operating elements at the front panel

1	LED "LDA"	Selected polarity of the laser: anode grounded
2	LED "LDC"	Selected polarity of the laser: cathode grounded
3		4½-digit LCD display
4	LED "mA"	Display is laser current (mA)
5	LED "mW"	Display is laser power (mW)
6	LED "OPEN CKT"	Indicates no laser diode connected
7	LED "LIMIT"	Adjusted current limit reached
8	LED "ENABLE"	Laser current is switched on
9	"ENABLE" Button	Enables the laser current on or off
10		Knob for adjusting the set value
11		Line switch
12	LIM I	Potentiometer for setting the current limit
13	CAL	Potentiometer for calibrating the power display
14	LED "PLD"	Displaying the optical output power
15	LED "IPD"	Displaying the photodiode current
16	LED "ILD"	Displaying the laser current
17	LED "ILIM"	Displaying current limit
18	DOWN Button	Used for selecting the display parameter



19	UP Button	Used for selecting the display parameter
20	LED "P"	Constant power mode
21	LED "I"	Constant current mode
22	"P" Button	Selecting constant power mode
23	"I" Button	Selecting constant current mode
24	PD RANGE	Potentiometer for setting the photodiode current range



**Fig. 2.2 Operating elements on the rear panel**

- 1 Modulation input/ analog control input "MOD IN"
- 2 Control Out (Laser Current Monitor)
- 3 Ventilation Fan
- 4 Connector for chassis ground
- 5 Connector "LD OUT" for laser diode, photodiode, interlock, status-LED (DB9F)
- 6 Switch "LD POL" for selecting the laser diode polarity
- 7 Serial number of the unit
- 8 Letterplate displaying the allowed line voltage
- 9 IEC 320 AC power receptacle and fuse holder

## 2.2 Starting up

Prior to starting operation of an LDC 500, check that the line voltage specified on the rear panel near the AC input jack agrees with your local supply and that the appropriate fuse is inserted.

For changing the line voltage refer to chapter 4.1.

Connect the unit to the line with the provided line cord. Turn the unit on by means of the line switch (11).

The chassis ground (R4) can be used for grounding the laser mount to the AC ground potential if required. The ground pin of the laser diode is internally connected to chassis ground.

After switching on the unit, the LCD display (3) should become visible and an LED indicating the displayed value (14 ... 17) should also light up. If no display is shown, please check line voltage and line fuse.

Use button (18) and (19) to select the desired value to be displayed at any time.

The LDC 500 is immediately ready to use after turning on. The rated accuracy is reached, however, after a warming-up time of approximately 10 minutes.

## 2.3 Operating the LDC 500

### 2.3.1 Setting the current limit "ILIM"

Before operating a laser diode, always set the current limit to the maximum desired operating current for your laser. Refer to the laser manufacturer's data to determine the safe operating current for the laser.

**NOTE: Many laser manufacturers supply generic data sheets that indicate a MIN / TYP/ MAX operating current for a laser. These numbers indicate the statistical spread of the maximum operating current for this model laser and typically DO NOT specify the maximum current for a specific laser. Be sure to check the actual measured data for your particular laser.**

#### **Procedure to set Ilim:**

- Switch on the unit with the "ON" button (11).
- Select parameter "ILIM" with button (18) or (19).
- Use a small flat blade screwdriver to set the desired current by adjusting the potentiometer "LIM I" (12).

#### **Note:**

The current limit can be displayed at any time by selecting the parameter "ILIM".

If the laser current reaches the set current limit "ILIM" during operation, the LED "LIM" (7) lights up and a beeper sounds a short warning signal.

The current limit can also be adjusted with the output switched on. In any case, you should avoid an adjustment when the LED "LIM" (7) lights up.

### 2.3.2 Selecting the laser diode polarity

With the LDC 500, all possible polarities of the laser diode and the monitor diode can be driven. The laser diode will always be driven with respect to ground. Compared with a floating driver stage, this operating mode has the advantages of higher security for the laser diode, better stability, and lower noise of the laser current by allowing the case of the laser diode to be grounded.

Prior to switching on the laser current, the correct polarity of the laser diode must be selected.

#### Procedure to select the laser polarity:

- Switch off the LDC 500.
- Select the designed polarity with the switch "LD POL" (6).

When operating laser diodes with a built-in monitor diode, the common pin of the laser diode and the photodiode is the ground pin.

The selected polarity of the output is indicated with the LED "LDA" (1) or "LDC" (2) LED to the left of the 4-1/2 digit display .

For safety reasons, there is a middle position of the switch "LD POL" (6) in which the laser is disabled.

**Note:**

If the middle position of the switch "LD POL" (6) is selected, neither the LED (1) nor (2) lights up. The laser current cannot be switched on.

If the laser diode is connected correctly (refer to chapter 2.3.3), but the polarity of the laser diode selected incorrectly via switch (6), the laser diode current cannot be switched on.

If the position of the switch "LD POL" (6) is changed with the laser current switched on, the laser diode current is switched off automatically.

**Note:**

For safety reasons you should select the polarity for the laser diode only with the laser diode current output switched off.

### 2.3.3 Connecting laser diode and photodiode

The LDC 500 can drive all laser diodes up to a maximum current range of 0.5A.

If laser mounts by *Thorlabs* are used, the input "LD INTF" of the laser mount is to be connected to the DB9 female jack labeled "LD OUTPUT" (5) with the cable LDC500-CAB.

If other laser diode mounts are used, connect the laser diode and, if provided, the photodiode with shielded cables to "LD OUTPUT" (5) according to the pin assignment shown in Fig 2.3.

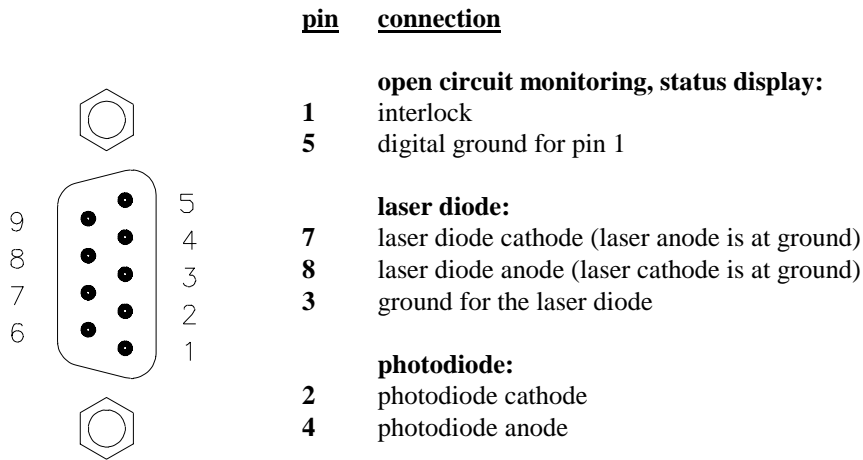

**Fig. 2.3 Pin assignment of jack "LD OUTPUT"**

**Selecting the laser pins to use:**

Determine which laser pin (anode or cathode) is attached to your laser package. This will be connected to pin 3. If the floating laser pin is the cathode attach it to pin 7 and leave pin 8 unconnected. If the floating pin is the laser anode, attach it to pin 8 and leave pin 7 unconnected.

**Safety Interlock**

Pin 1 and pin 5 of the LD OUTPUT jack (5) are contacts to allow for an optional externally connected Interlock switch. Open contacts on this switch will prevent the unit from operating or shut the unit down if it is already operating. The unit can only be Enabled if the switch contacts are closed.

If no interlock switch is used, this feature can be bypassed by connecting Pin 1 to Pin 5 with a wire as shown in Fig. 2.4.

**Connecting the laser diode and photodiode**

Connect laser diode and photodiode according to Fig. 2.4 to the LDC 500.

The ground connection of the laser diode (pin 3) may be connected to the anode of the photodiode (pin 4) or to the cathode of the photodiode (pin 2). This connection should be as close as possible to the laser diode to avoid measurement errors.

If the polarity selected with the switch "LD POL" (6) and the connection of the laser diode do not agree, no current will flow through the laser diode.

The laser diode is always driven with respect to ground. Compared to a floating driver stage, this operating mode has the advantages of higher security for the laser diode and better stability of the laser current.

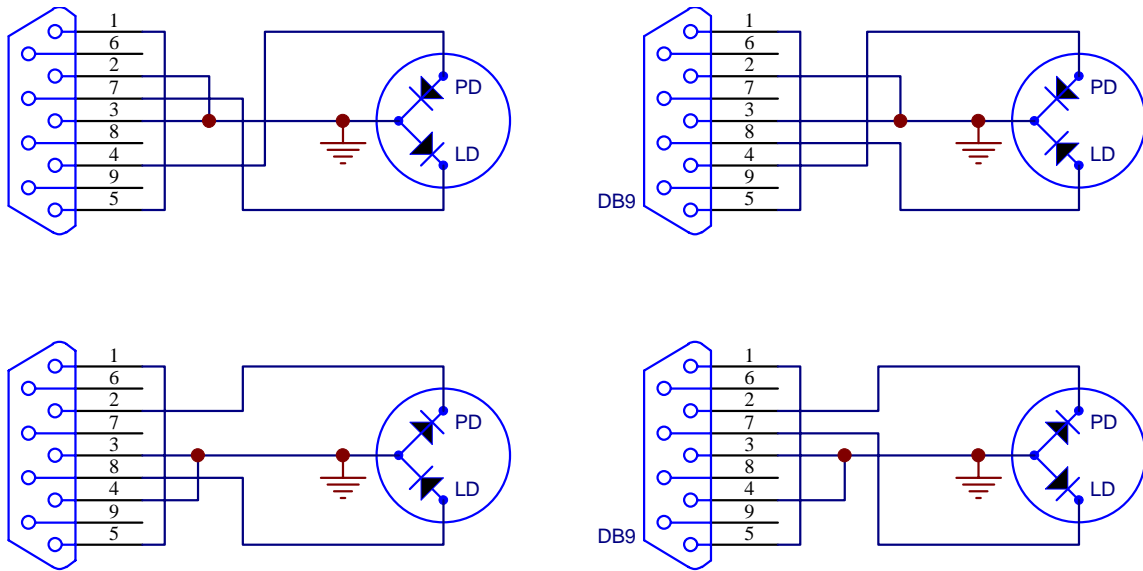

Note: Pin 3 of the DB9 is always at the signal ground. This allows the case of laser to be grounded for ESD protection.

**Fig. 2.4 Connecting laser diode and photodiode**

If the photodiode should be operated with bias, a battery can be connected in series to the photodiode.

With polarity LDA grounded, connect the positive terminal of the battery to the cathode of the photodiode and the negative terminal of the battery to pin 2.

With polarity LDC grounded, connect the negative terminal of the battery to the anode of the photodiode and the positive terminal of the battery to pin 4.

**Note:**

**A wrong polarity of the battery may destroy the photodiode.**

**2.3.4 Constant current mode (CONST I)**

**Procedure to operate in constant current mode:**

- Switch on the LDC 500 (refer to chapter 2.2).
- Select a suitable current limit "ILIM" (refer to chapter 2.3.1).
- Select the appropriate laser polarity (refer to chapter 2.3.2).
- Connect the laser diode (refer to chapter 2.3.3).
- Select the display "ILD" with button (18) or (19).

- Set the adjust knob (10) completely counter-clockwise (CCW).
- Press the button "I" (23) to select constant current mode.
- Switch on the output by pressing key "ENABLE" (9). The LED "ENABLE" (8) lights up, the output is activated and the current slowly rises (about 1 s) to the value set with the adjust knob (10).

**Note:**

The current output can only be switched on if the jack "LD OUTPUT" (R5) is connected correctly.

The display shows the laser current "ILD".

- With the adjust knob (10), the laser current can be set continuously between 0 mA and the selected current limit "ILIM".

If the laser current "ILD" reaches the set current limit "ILIM" during operation, the LED "LIM" (7) lights up, a beeper sounds a short warning signal, and the laser current is limited to the value of the current limit "ILIM".

If the LED "LIM" (7) lights up, noise and ripple no longer correspond to the specifications for normal operation (refer to chapter 2.3.1). However, exceeding the set current limit "ILIM" is not possible.

If the connection to the laser diode is interrupted during operation, the laser diode current is switched off automatically. LED "ENABLE" (8) turns off, LED "OPEN CKT" (6) lights up and a beeper sounds a short warning signal.

If the output is switched on while the interlock is closed and there is no laser diode connected, at first the LED "ENABLE" (8) lights up and the output is switched on. Immediately afterwards the LDC 500 recognizes the absence of the laser diode, switches the output off, the LED "ENABLE" (8) turns off, and the LED "OPEN CKT" (L6) lights up.

After pressing "ENABLE" (9), the LED "OPEN CKT" (6) turns off and the output can be switched on again by pressing "ENABLE" (9).

If a photodiode is connected, the display can be switched to display the photodiode current "IPD" or the optical power "PLD" by pressing buttons (18) or (19).

The laser current can be modulated via the connector "MOD IN" (R3) (refer to chapter 2.3.7).

### **2.3.5 Constant power mode (CONST P)**

With a photodiode connected, the laser diode can also be driven in constant power mode.

#### **Procedure to operate in constant power mode:**

- Start operating the LDC 500 in constant current mode (refer to chapter 2.3.4)
- Select the display "IPD" with buttons (18) or (19).
- Check whether an appropriate laser diode current "IPD" is available. A photodiode current of at least 5  $\mu$ A must be available for stable operation of the power control.

**Note:**

If "IPD" is negative the anode and the cathode of the photodiode must be exchanged.

- Disable the laser by pressing "ENABLE" (9) button to switch off the laser current.
- Select constant power (CONST P) with "P" (22).
- Set the adjust knob (10) completely CCW.
- Switch on the output by pressing "ENABLE" (9). The LED "ENABLE" (8) lights up, the output is activated, and the current slowly increases (about 1 s) to the value set with the adjust knob (10).
- With the adjust knob (10), you can continuously set the photodiode current "IPD", and thus the optical power of the laser diode, until the laser current "ILD" reaches the selected current limit "ILIM".

If the desired photodiode current "IPD" cannot be set exactly enough with the adjust knob (10), the range of the knob (10) can be adjusted to the provided photodiode current in wide ranges with the potentiometer "PD RANGE" (24) (refer to changing the IPD setting range).

If no photodiode is connected or the polarity of the photodiode current was selected incorrectly (refer to chapter 2.3.2), the laser current "ILD" increases to the set current limit "ILIM" after the output is switched on.

If the photodiode current "IPD" is interrupted in constant power mode, the laser current "ILD" increases to the set current limit "ILIM".

If the laser current "ILD" is limited by the selected current limit "ILIM", ripple and noise no longer correspond to the specifications for normal operation (refer to chapter 2.3.1). However, the set maximum current "ILIM" cannot be exceeded.

If the connection to the laser diode is interrupted during operation, the output is switched off automatically. LED "ENABLE" (8) turns off, LED "OPEN CKT" (6) lights up, and a beeper sounds a short warning signal.

If the output is switched on while the interlock is closed and there is no laser diode connected, at first the LED "ENABLE" (8) lights up and the output is switched on. Immediately afterwards the LDC 500 recognizes the absence of the laser diode, switches the output off, the LED "ENABLE" (8) turns off, and the LED "OPEN CKT" (6) lights up.

After pressing "ENABLE" (9) the LED "OPEN CKT" (6) turns off and the laser diode current output can be switched on again by pressing "ENABLE" (9).

The laser current can be modulated via the connector "MOD IN" (R3) (refer to chapter 2.3.7).

### **Changing the "IPD" setting range**

To guarantee an easy setting of the operating point in constant power mode, even with small photodiode currents, the full scale of the adjust knob (10) can be set with potentiometer "PD RANGE" (24) between 0.6 mA and 2 mA.

### **Procedure to change the Ipd range:**

- Turn the potentiometer "PD RANGE" (24) completely CCW. Full scale = 0.6 mA.
- Turn the adjust knob (10) completely CCW.

- Select constant power mode CONST P. Connect the laser diode and the photodiode and switch on the laser current.
- Set the desired photodiode current with the adjust knob (10).

If the desired operating point cannot be reached, even if the adjust knob (10) is turned completely clockwise (CW) (i.e.  $IPD > 0.6$  mA), turn the potentiometer "PD RANGE" (24) to CW until the desired setting range has been reached.

**Note:**

Changing the position of the potentiometer "PD RANGE" (24) changes the set value in constant power mode. In constant current mode the potentiometer "PD RANGE" has no function.

### 2.3.6 Calibrating the optical power display

In addition to the photodiode current "IPD", the optical power of the laser diode can also be displayed. The actual optical power is shown only after calibrating the power display. For calibration, the potentiometer "CAL PD" (13) is used.

#### Procedure to calibrate the optical power display:

- Select constant current mode CONST I.
- With the adjustment knob (10), either set a laser current "ILD" or a monitor current "IPD" where the optical output power of the laser diode is known, e.g. from the data sheet of the laser diode. Alternatively, the laser power can also be measured with an optical power meter.
- Select the display "PLD" (5) with button (18) or (19).
- Calibrate the display "PLD" with potentiometer "CAL PD" (13) to the value of the actual optical power. If the display can not be set as high as the laser power, it may be necessary to change the decimal point position of the display (see Section 4.3) and repeat this procedure.

### 2.3.7 Analog modulation of the laser diode

To generate certain time functions, the laser current "ILD" or the photodiode current "IPD" can be modulated via an independently grounded modulation input "MOD IN" (R1).

"ILD" and "IPD" are calculated as:

$$ILD = ILD\ SET + I_{MAX} * U_{MOD} / 10\ V$$

or  $IPD = IPD\ SET + 0.2\ mA * U_{MOD}$

with:

ILD SET or IPD SET: value set with (L10)

UMOD: voltage at "MOD IN" (R1)

#### Procedure to operate the analog modulation input:

- Start operation in constant current or constant power mode (refer to chapter 2.3.4 or 2.3.5) and set the desired set value with the adjust knob (10).



- Connect the modulation source to the jack "MOD IN" (R1). Avoid ground loops when connecting the function generator.

If the laser current "ILD" reaches the set current limit "ILIM" in operation, the LED "LIM" (7) lights up, a beeper sounds a short warning signal, and the laser current is limited to the value of the current limit "ILIM".

If the laser current "ILD" is limited by the selected current limit "ILIM", ripple and noise no longer correspond to the specifications for normal operation (refer to chapter 2.3.1). However, the set maximum current "ILIM" cannot be exceeded.

### **2.3.8 Control Output (Laser Current Monitor)**

A rear panel BNC labelled CTL OUT allows the laser current to be monitored with a voltmeter, strip chart recorder, oscilloscope, etc.. The output range is from 0 to 10V with a transfer coefficient of 50mA/V.

### **3 Remote control**

The LDC 500 includes analog inputs to provide simple, semi-automatic control systems to be assembled.

The following control or read back functions are possible:

#### **Interlock**

If a relay contact or an open collector transistor is switched in the interlock line (refer to chapter 2.3.3), the output can be switched off automatically at any time. However, an automatic reactivation is not possible.

#### **Setting a set value**

If the adjust knob (10) is set to the CCW stop, the set value can be controlled with an analog voltage of 0 ... 10 V, thus a setting via a D/A converter card is easily possible.

## 4 Service

### 4.1 Changing the line voltage

The LDC 500 can be operated at line voltages of 100 V, 115 V or 230 V.

#### **Procedure to change the line voltage:**

- Switch off the LDC 500 and remove the line cord.
- Remove the 2 screws of the top cover (on the bottom of the unit).
- Slide the top cover off towards the back.
- Select the desired line voltage at the voltage selector switch near the transformer.
- Push the top cover back onto the unit and fasten it with the 2 screws.
- If necessary, change the main fuse (refer to chapter 4.2).

### 4.2 Replacing the main fuse

If the main fuse has blown due to line distortion, incorrect line voltage or other causes, it can be easily replaced from the rear without opening the unit.

#### **Attention:**

**To avoid fire risk, only the fuse designated for the line voltage must be used.**

The recommended fuses are:

100 V and 115 V:	0.5 AT
230 V:	0.25 AT

#### **Procedure to replace fuse:**

- Turn off the LDC 500 and disconnect the line cord.
- Open the fuse drawer of the main connector (R9) with a screwdriver.
- Replace the defective fuse and close the drawer.

### **4.3 Adjusting Power Display decimal point**

The decimal point of the power display may be adjusting by installing or removing a jumper inside the LDC500. This allows the display to show up to 20mW (jumper JP6 not installed) or up to 200mW (jumper JP6 installed).

- Switch off the LDC 500 and remove the line cord.
- Remove the 2 screws of the top cover (on the bottom of the unit).
- Slide the top cover off towards the back.
- Locate the 2 pin jumper labelled JP6 located near the front of the PCB.
- Install a shorting jumper across JP6 to set the display range to 0-200mW. Remove any shorting jumper across JP6 to set the range to 0-20mW.
- Replace the cover and secure with the 2 mounting screws.

### **4.4 Maintenance and repair**

The LDC 500 does not need regular maintenance by the user. The unit and the LCD display can be cleaned with a soft, moist cloth and a mild detergent.

The LDC 500 does not contain any modules that could be repaired by the user himself. If any malfunction occurs, the whole unit must be sent back to *Thorlabs*.

To guarantee the specifications given in chapter 1.2 over a long period, it is recommended that the unit be calibrated by *Thorlabs* every two years.