

TPA850P10 - August 28, 2018

Item # TPA850P10 was discontinued on August 28, 2018. For informational purposes, this is a copy of the website content at that time and is valid only for the stated product.

TAPERED AMPLIFIER

- ▶ 850 nm Center Wavelength
- ▶ 1 W Output Power
- ▶ Controlled, Collimated Output Beam
- ▶ 14-Pin Butterfly Package

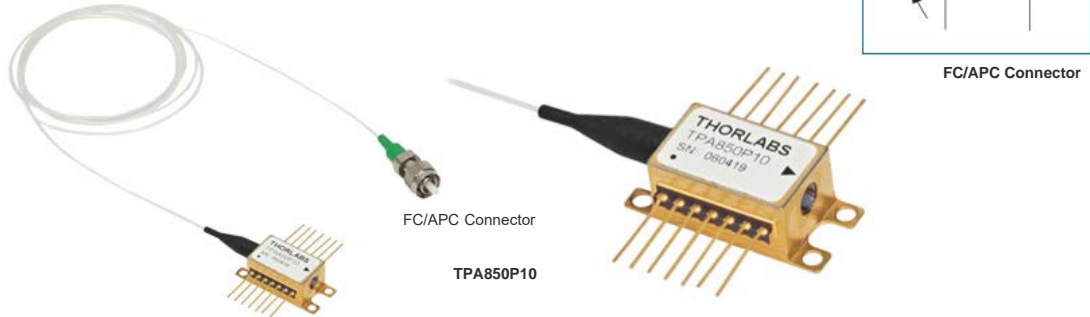

OVERVIEW

Features

These items will be retired without replacement when stock is depleted. If you require this part for line production, please contact our OEM Team.

Limited STOCK

- Output Centered at 850 nm
- 1 W Output Power
- PM Fiber Input, FC/APC Connector
- 14-Pin Butterfly Package

This Thorlabs' Tapered Amplifier consists of an optical amplifier integrated into an industry-standard, 14-pin butterfly package. Available at a center wavelength of 850 nm, this modular tapered amplifier is easy to integrate into larger systems. The output of the amplifier is free space. Thorlabs recommends using an optical isolator (IO-3-850-HP) to prevent back reflections from damaging the amplifier.

The input to the butterfly package is fiber coupled to simplify alignment procedures that customers typically have to perform when working with a traditional tapered amplifier. In addition, the butterfly package protects the amplifier itself from damage and contamination, thus yielding an extended lifetime. Thorlabs' tapered amplifier design also incorporates collimating and beam-shaping optics to produce a nearly circular, collimated output beam. The FC/APC connectors and PM fiber input enables connection to any type of seed laser, such as home-built or custom External Cavity Lasers. For maximal coupling, the polarization axis of the input beam should be aligned to the slow axis of the tapered amplifier's PM fiber. For this amplifier, the slow axis is aligned to the key on the fiber connector. For more information on the needed input laser power and the associated power output from the tapered amplifier, please see the *Graphs* tab.

This tapered amplifier specifies both a maximum current and maximum power. These are tandem specs and therefore both must be observed simultaneously. In the normal course of operation, the chip will typically reach maximum power before reaching the current threshold. For example, with a seed laser power of 5 mW, the TPA850P10 will typically output about 1 W with a drive current of about 2.5 A (the maximum current output of the LDC2500B). Additionally, it is recommended that the seed power be a few mW in power (5 - 10 mW is a decent range for most tapered amplifiers) in order to reduce the load on the TEC. Due to inefficiencies in the chip, at very low seed powers (<1 mW) there is considerable heat generation and thus considerable effort on part of the TEC to properly maintain chip temperature. As the seed power increases, these inefficiencies are overcome and the heat generation is reduced. Over about 10 mW, there is no significant gain in thermal efficiencies; thus there is no reason, in terms of temperature regulation, to go above 10 mW input power.

These chips have a maximum operating temperature range of 10 to 40 °C. It should be noted that the package temperature must be kept low enough (<35 °C) for the internal TEC to properly pump heat away from the chip. Our LDC2500B dual current and TEC controller (available below) is designed specifically to meet the thermal and power needs of our tapered amplifier. It has two TEC's and specially designed heat sinks to address the problem of overheating. The case temperature of the tapered amplifiers is controlled by the second TEC in order to stabilize their gain and to keep the chip temperature under control.

Specifications

Item #	TPA850P10
Center Wavelength	850 nm
Small Signal Gain ^a	24 dB
Amplification Bandwidth	CWL ± 5 nm
Operating Current	2.5 A
Output Power	1 W
Output Polarization State	TE ^b
Case Operating Temperature ^c	10 to 40 °C
Fiber	PM780-HP
Fiber Length	1 m
Connector	FC/APC, 2.0 mm Narrow Key
Internal Package Thermistor	10 kΩ
Steinhart-Hart Coefficients	A: 1.1292×10^{-3} B: 2.3411×10^{-4} C: 8.7755×10^{-8}
TEC Operating Current (T _{case} = 25 °C)	2 A
TEC Operating Voltage (T _{case} = 25 °C)	3 V
Internal Package Thermistore	10 kΩ
Laser Class	4
Compatible Controller	LDC2500B

- At 2 mW seed power
- The polarization is parallel to the package's base.
- Requires an adequate heat sink and non-condensing atmosphere.

(typically 25 - 30 °C). Other integrated driver systems, such as our CLD1015, and mounts, such as our LM14S2, cannot provide sufficient thermal control and could result in damage to the tapered amplifier if employed.

GRAPHS

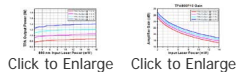

[Click to Enlarge](#)

[Click to Enlarge](#)

RAMAN SPECTROSCOPY

- ▶ Probe Vibrational, Rotational, and Other Low-Frequency Modes of Molecules
- ▶ Study Scattering Cross-Sections and Population Densities of Molecules

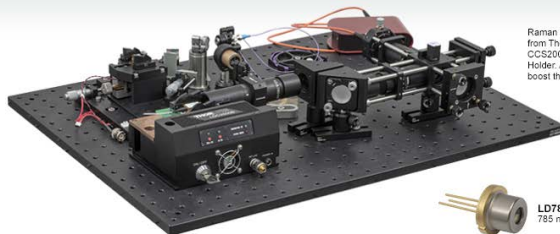

Raman Spectroscopy Experiment constructed from Thorlabs' components, including the CCS200 spectrometer and CVH100 Cuvette Holder. A tapered amplifier is used to further boost the power of the laser source.

LD785-SEV300
785 nm, 300 mW

LD785-SE400
785 nm, 400 mW

Raman Spectroscopy: The Approach

Raman spectroscopy is a spectroscopic technique that detects photons that have undergone Raman scattering. Since Raman scattering is relatively weak compared to Rayleigh scattering, one of the main historical problems with Raman spectroscopy had been separating out the weak Raman signal from the strong Rayleigh signal. Today, this problem is easily remedied with notch or edgepass filters. Similarly, recording the Raman spectrum has been aided greatly by the advent of CCD spectrometers. The image below shows a Raman Spectrometer system constructed using Thorlabs components, designed for 780 nm light using a tunable laser kit fed into a TPA780P20 Tapered Amplifier.

In this side-scattering configuration, the polarization of the laser was set vertically with respect to the table (horizontally polarized light cannot scatter horizontally). Isopropyl alcohol, contained in a cuvette and mounted in a CVH100 Cuvette Holder, was used as a sample. The cuvette holder allowed optical access to all four sides of the cuvette, making it ideal for a Raman spectrometer. The scattered light was collected by a fiber and fed into Thorlabs' CCS200 spectrometer. The Raman spectra for isopropyl alcohol, measured with this 780 nm Raman spectrometer, is presented to the lower right.



[Click to Enlarge](#)

A Raman spectrometer constructed from Thorlabs components.

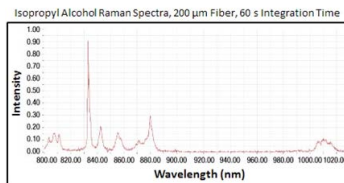

[Click to Enlarge](#)

Raman spectrum for isopropyl alcohol, measured with the 780 nm Raman spectrometer discussed above.

Power in Raman Spectroscopy

Power is important in Raman measurements. Raman scattering is a weak, low-probability event with a $1/\lambda^4$ wavelength-dependent efficiency. Sensitivity and integration time for data accumulation improve with increasing power, as long as the notch or edgepass filter can sufficiently attenuate the strong Rayleigh signal and the power is below the damage/saturation thresholds of the devices. To address this need, Thorlabs offers several laser diode packages for 785 nm that have output powers on the order of several hundred milliwatts, such as the LD785-SE400 or LD785-SEV300, capable of delivering 400 mW and 300 mW of power, respectively.

Laser Sources for Raman Spectroscopy

When using a laser to produce Raman scattering in a sample, sufficient power is important to improve the sensitivity and integration time of measurements. Thorlabs has invested in developing our GaAs material design and processing capabilities in order to produce reliable devices while improving the output power and available wavelengths.

A selection of Thorlabs' laser sources useful for Raman spectroscopy is outlined below.

GaAs-Based Fabry-Perot and DFB Semiconductor Laser Diodes

Our line of GaAs-based gain chips and diode lasers offers the possibility to improve the signal quality of an instrument by dropping in a higher power replacement or to design a new instrument around a customized diode. Traditionally, many Raman spectrometers have been built around 785 nm chips. Thorlabs offers two $\varnothing 9$ mm TO can laser diodes at 785 nm, with one diode providing 400 mW of power (LD785-SE400), and the other, a wavelength-stabilized laser diode, providing 300 mW of power (LD785-SEV300).

For some applications, other wavelengths may be desired to balance the $1/\lambda^4$ Raman signal dependence with the background fluorescence of a particular sample. The GaAs material system can be designed to produce wavelengths from 630 nm up to about



LD785-SEV300
TO-Can Fabry-Perot Laser Diode

LD785-SE400
TO-Can Fabry-Perot Laser Diode

[Click to Enlarge](#)

1050 nm. In these cases, Thorlabs' OEM manufacturing capabilities may be able to develop a solution to suit a particular application. Please contact Sales-TQE@thorlabs.com for more information or to discuss an application.



Click to Enlarge

Tapered Amplifiers

To achieve powers of 1 W in a free-space beam, it is possible to use a tapered gain medium. Thorlabs offers a tapered amplifier for use with seed sources at 850 nm with maximum output powers of 1 W.

The butterfly package offers two major advantages to working with bare chips. First, the input side is fiber coupled so the seed can be fed into the amplifier via the FC/APC connector. Second, a lens system within the package on the output side helps to collimate and correct the strong astigmatism of the bare chip.

More information about the tapered amplifiers can be found here.

Delivering Light to the Sample

The Raman spectroscopy experiment described above was constructed using components from Thorlabs' extensive line of optomechanical components, optic mounts, and optics. The setup was built on a breadboard using our SM1 lens tube and 30 mm cage systems. Components were mounted using our Ø1/2" and Ø1" post assemblies and bases. Alternatively, our extensive line of optical rails provides another option for building a support structure for your experiment. In addition to our standard line of optic mounts, Polaris® low-drift kinematic mirror mounts are available for mounting optics in the system that require long-term alignment stability, particularly in conditions where the temperature may cycle in between experimental runs.

Optics

Thorlabs offers a wide range of mirrors which can be used to guide light through the system. Besides our plano broadband-dielectric- and metallic-coated mirrors, we also offer concave and off-axis parabolic mirrors that can be used to focus or collimate light within the system without introducing chromatic aberration.



Click to Enlarge

Raman scattering produces a relatively weak signal compared to optical signals produced by other mechanisms, such as Rayleigh scattering or fluorescence from the sample. Filters that can remove unwanted signals are an important part of a Raman spectroscopy system. Thorlabs' line of premium hard-coated edgepass filters and bandpass filters provide a solution. Our line includes longpass filters with cutoff wavelengths between 400 nm and 1500 nm and bandpass filters with center wavelengths between 400 nm and 1064 nm.

Fiber

Fiber patch cables can be a convenient way to simplify light introduction or collection in Raman spectroscopy applications. They are available with a variety of fiber core sizes, connector types, and cable lengths. If you cannot find a patch cable suitable for your application, you can design your own custom patch cable using our custom cable configurator.

Protecting the Laser from Back Reflections

Back reflections from the optics in a setup can re-enter the cavity of a laser, potentially causing mode-hopping, amplitude modulation, frequency shifts, or even damage to the laser source. Optical isolators are passive magneto-optic devices that only allow light to travel in one direction, protecting the laser source from back reflections or other signals that may occur in the system after the isolator. Thorlabs' optical isolators are available in fiber coupled and free-space configurations with center wavelengths ranging from the UV to the IR. While our most popular isolators are shipped from stock to provide faster service, custom isolators are also available. Visit the Custom Isolator page for more information or to request a quote.

Sample Holder

Thorlabs' CVH100 cuvette holder was used to integrate sample solutions into the Raman spectrometer described above. The holder can be used with both macro and micro cuvettes and features four light ports. A filter can be added via a filter holder that fits into a slot on the top of the CVH100. The cuvette holder also comes with a fiber adapter that includes a collimating lens, allowing output light to be fiber coupled into a detector.



Click to Enlarge

Detection

Thorlabs offers a line of CCD spectrometers that can be used to record the spectrum produced by a Raman spectroscopy setup. These compact spectrometers feature an SMA connectorized input and come with an SMA-to-SMA connectorized fiber patch cable. Each spectrometer is wavelength and amplitude calibrated. The spectrometers are controlled via a software package that includes a graphical user interface and extensive set of drivers for data acquisition and analysis.



Click to Enlarge

Raman Spectroscopy: The Basics

Discovered by Krishna and Raman in 1928, Raman spectroscopy has given rise to a multitude of specific techniques, from Linear Raman Spectroscopy to Coherent Anti-Stokes Raman Spectroscopy, and proves itself to be a powerful tool for spectroscopic analysis. One of the most common applications of Raman spectroscopy is to measure vibrational, rotational, and other low-frequency modes of a system (e.g., molecules).

Raman scattering by molecules is a type of inelastic scattering, in which the final and initial energy states are different, resulting in the molecules being in a different quantum state. Raman scattering is in contrast to Rayleigh scattering, an elastic scattering event, in which the final and initial energy states are the same (i.e., energy is conserved), and the molecules remain in the same quantum state. Both Rayleigh and

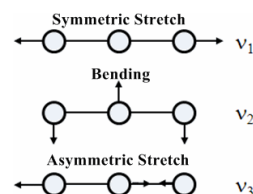

Raman scattering are dependent upon the polarizability of a molecule: the stronger the polarizability of a molecule, the larger the scattering cross section. While both Rayleigh and Raman scattering are second order processes that scale as $1/\lambda^4$, the scattering rate for Rayleigh scattering is on the order of 10^3 times greater than that for Raman scattering [1]. Typically, in Raman spectroscopy, the stronger Rayleigh signal must be extricated since it carries little pertinent information about the vibrational modes.

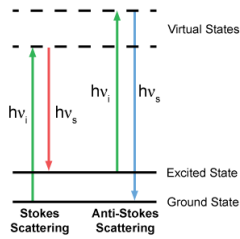

Since Raman spectroscopy requires the polarizability change to be a function of normal coordinates, one of its limitations is that it cannot measure direct dipole transitions. Because of this, Raman spectroscopy is sometimes utilized with other techniques to fully measure the vibrational and rotational states of a molecule. For example, in the CO_2 molecule, of the three vibrational states depicted in the figure to the right, only ν_1 (symmetric stretching) is Raman active. The other two vibrational states (bending and anti-symmetric stretching) are infrared active [2]; thus, Raman and infrared spectroscopy comprise complementary measurements.

Raman scattering is a two-photon process, wherein the incident photon ($h\nu_i$) is absorbed by the molecule, and the

molecule is excited to a "virtual" level (not necessarily a stationary Eigenstate). Once promoted to this virtual level, the molecule will decay to an excited state and emit a "scattered" photon ($h\nu_s$). In general, the molecule begins in the ground state, and thus, the energy of the scattered photon is less than that of the incident photon. The energy difference is related to the vibrational, rotational, or electronic energy of the molecule [2]. The emission of a scattered photon possessing less energy than the incident photon is called Stokes radiation, whereas the emission of a scattered photon possessing more energy than the incident photon is known as anti-Stokes radiation. The figure to the left depicts Stokes and anti-Stokes radiation. Since anti-Stokes radiation requires that the molecule already be in the excited state before scattering, the peak intensity of the anti-Stokes signal is lower than peak intensity of the Stokes signal.

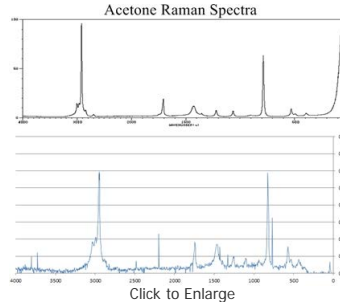

Click to Enlarge
Raman spectrum for Acetone, measured with a 532 nm Raman Spectrometer (bottom), and compared to published results (top).

The graphs to the right show the results of a typical Raman spectrum for acetone, taken with Thorlabs' DJ532-40 laser diode, compared to published results. For standard linear Raman spectroscopy, information about the molecule is obtained through several measurements. The linewidth of the scattered radiation can yield a plethora of diverse information about the system. For example, in a gas sample, the linewidth can represent Doppler width, collisional broadening, natural linewidth, etc. Polarization analysis of the Raman spectrum also yields additional information about anisotropy and the polarizability tensor. Additionally, information about molecular orientation or vibrational symmetry can be extracted from polarization analysis. Finally, the intensity of the Raman lines relates to the scattering cross section and population density of molecules in the initial state.

[1] D. W. Ball, *Spectroscopy* **16**(2), 28 - 30 (2001)
 [2] W. Demtroder: *Laser Spectroscopy Volume 2*, 4th Edition (Springer-Verlag, Berlin, Heidelberg, 2008)
 [3] G. Dent and E. Smith: *Modern Raman Spectroscopy: A Practical Approach*, (Wiley, Chichester, United Kingdom, 2005)
 [4] I. R. Lewis and H. Edwards: *Handbook of Raman Spectroscopy*, (CRC Press, 2001)
 [5] R. L. McCreery: *Raman Spectroscopy for Chemical Analysis*, (John Wiley & Sons, Inc., 2000)

PIN DIAGRAM

Pin Identification

- | | |
|----------------------|-----------------|
| 1. TEC + | 14. TEC - |
| 2. Thermistor (Chip) | 13. Case |
| 3. NC | 12. NC |
| 4. NC | 11. Dev Cathode |
| 5. Thermistor (Chip) | 10. Dev Anode |
| 6. Thermistor (Case) | 9. NC |
| 7. Thermistor (Case) | 8. NC |

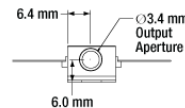
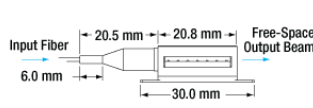
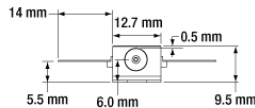
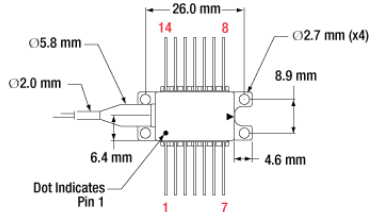

Tapered Amplifier

Part Number	Description	Price	Availability
TPA850P10	850 nm Tapered Amplifier, 1 W, 10 nm BW, Butterfly Pkg, PM Fiber, FC/APC	\$6,681.00	Lead Time

Tapered Amplifier Controller

- ▶ Designed for Thorlabs' Tapered Amplifiers
- ▶ Integrated Current and TEC Controllers
- ▶ Compatible with 14-Pin Butterfly Packages
- ▶ Drive Current up to 2.5 A

- ▶ Dual TEC for Chip and Package Temperature Control
- ▶ USB Connectivity or Standalone Operation

Thorlabs offers the LDC2500B Tapered Amplifier Controller that is ideal for use with the Tapered Amplifiers, as well as other standard 14-pin butterfly packages where case temperature control is required. For more information on this product, please see the complete presentation here. Please contact Tech Support if you have any questions.

Part Number	Description	Price	Availability
LDC2500B	Tapered Amplifier Current and TEC Controller, 2.5 A, 14-Pin Butterfly Package	\$4,193.22	Today

