

Piezoelectric Stack, 150 V, 40.0 μm , Two End Plates



PK4GA3H5P2

Description

The PK4GA3H5P2 piezoelectric stack consists of multiple chips (with isolated inner hole) which are bonded via epoxy and glass beads. It offers a maximum displacement of $40.0 \mu\text{m} \pm 15\%$. A red wire is attached to the electrode that should receive positive bias, and a black wire is attached to the electrode that should be grounded.

Specifications

PK4GA3H5P2 ^a	
Drive Voltage Range	0 - 150 V
Displacement (Free Stroke) at 150 V	$40.0 \mu\text{m} \pm 15\%$
Hysteresis	<15% (See Graph on Next Page)
Load (Recommended) ^b	700 N (155 lbs)
Blocking Force at 150 V	1600 N (360 lbs)
Resonant Frequency	30 kHz (No Load)
Impedance at Resonant Frequency	90 m Ω
Dissipation Factor	<2.0%
Capacitance	$5.5 \mu\text{F} \pm 15\%$
Operating Temperature	-25 to 130 °C
Curie Temperature	230 °C
External Electrodes	Screen-Printed Silver
Outer Dimensions ^c	7.3 mm x 8.9 mm x 45.0 mm with $\varnothing 3.0$ mm Through Hole
Piezo Stack Dimensional Tolerance	± 0.1 mm

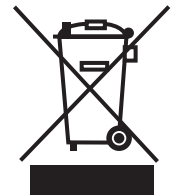

- All specifications are quoted at 25 °C, unless otherwise stated.
- The displacement may vary slightly for different loads, and the maximum displacement occurs when used with the recommended load.
- Outer dimensions include the electrodes, wire connection area, and Kapton® tape but not the length of the wires.

Drawing

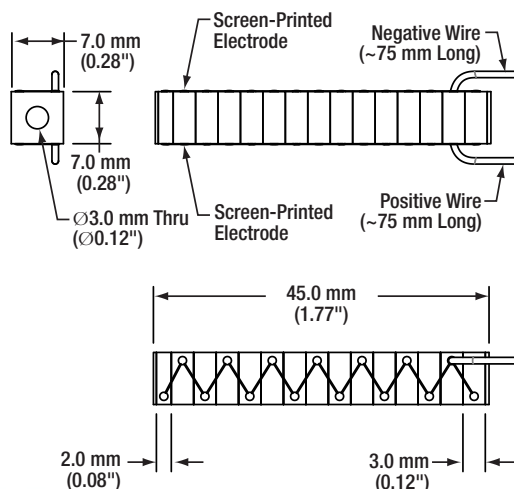

July 1, 2020

CTN009269-S01, Rev B

Typical Performance Plots

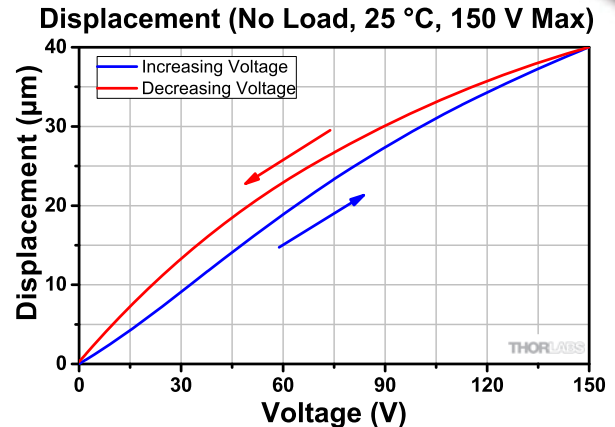
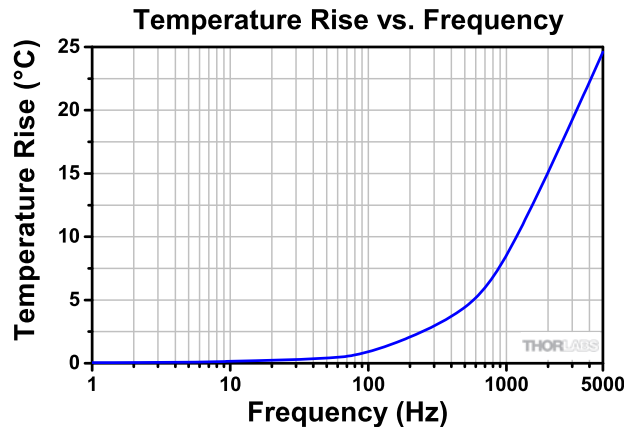

Temperature rises were measured after applying a sine-wave drive voltage ranging from 0 to 150 V at the specified frequency for 10 minutes.

Operation

Electrical Considerations

- The electrode attached to the red wire should be positively biased, and the electrode attached to the black wire should be grounded. The recommended maximum drive voltage is 150 V, and the absolute maximum voltage is 150 V. Exceeding 150 V will decrease the device's lifespan and may cause mechanical failure. Reverse biasing the device may cause mechanical failure.
- If it becomes necessary to reattach the wires to the electrodes, use a soldering iron at a temperature no greater than 370 °C (700 °F) for a maximum of 2 seconds per spot. Solder to the middle of the electrode, keeping the spot as small as possible.
- **Caution:** after driving, the piezo is fully charged. Directly connecting the red and black wires has the risk of electricity discharging, spark, and even failure. We recommend using a resistor (>1 kΩ) between the wires to release the charge.

Attaching Devices to the Piezo

- Any epoxy which cures at a temperature lower than 80 °C is safe to use. We recommend Thorlabs Item Numbers 353NDPK or TS10. Loctite Hysol 9340 is also usable.
- Loads should only be attached to the central area of the largest face since the edges do not translate. Attaching a load to the smaller faces may lead to mechanical failure.

Storage Instructions

- Do not store the device at temperatures above 80 °C.
- Do not store the device in humid environments. The relative humidity (RH) should be less than 40%.
- Do not immerse the device in organic solvents.
- Do not use the device around combustible gases or liquids.