

FIBER SPECIFICATIONS*					
ITEM #	CORE DIAMETER	CLADDING DIAMETER	COATING DIAMETER	NA	WAVELENGTH RANGE
FT400EMT	400 ± 8 μm	425 ± 10 μm	730 ± 30 μm	0.39	400 to 2200 nm

*SPECIFICATIONS BASED ON BARE FIBER DATA

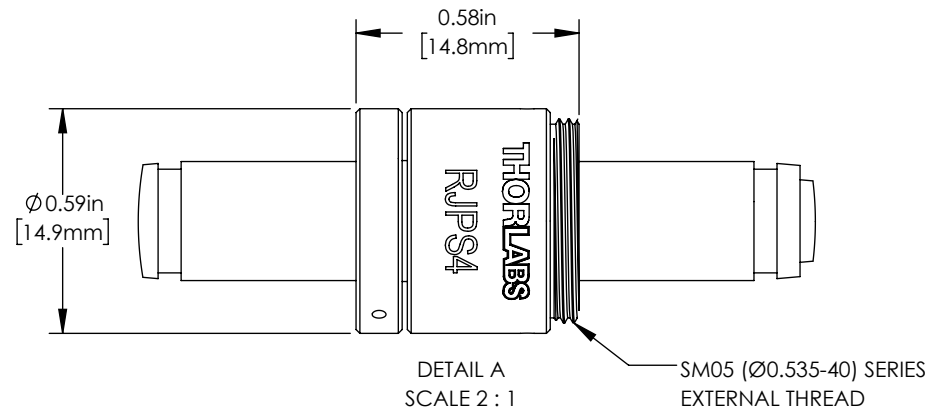
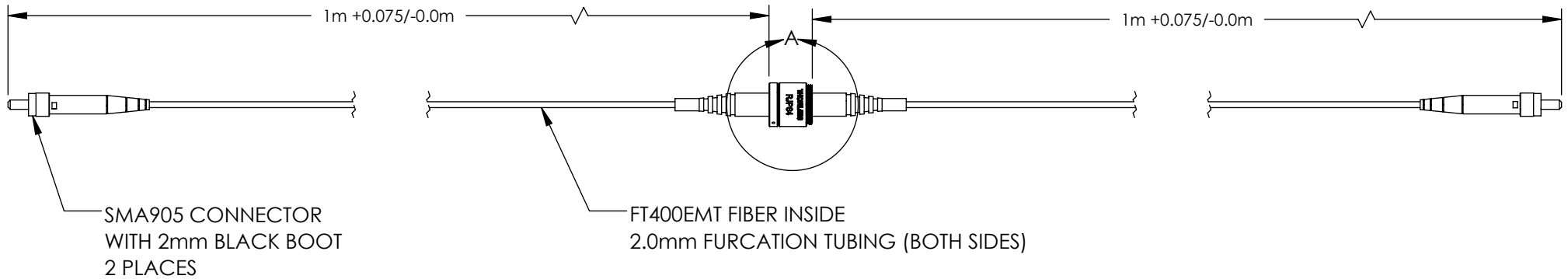

- INCLUDED BUT NOT SHOWN:
- 2 PROTECTIVE DUST CAPS

ROTARY JOINT SPECIFICATIONS	
INSERTION LOSS	<2.0dB
ROTATIONAL VARIATION	+/-0.4dB
STARTUP TORQUE	<0.01Nm

FOR INFORMATION ONLY
NOT FOR MANUFACTURING PURPOSES

DRAWING PROJECTION			THORLABS www.thorlabs.com	
NAME	DATE	FIBER OPTIC PIGTAILED ROTARY JOINT, 400um, 0.39NA FIBER, SMA		
DRAWN	CAL	10/24/13	MATERIAL	
APPROVAL	BAG	03/13/19	N/A	
COPYRIGHT © 2019 BY THORLABS			ITEM #	REV
VALUES IN PARENTHESIS ARE CALCULATED AND MAY CONTAIN ROUND OFF ERRORS			RJPS4	C
			APPROX WEIGHT	
			342g	