THORLABS

SLS201L(/M)

SLS202L(/M)

**Stabilized Tungsten
Light Sources**

User Guide



















Table of Contents

Chapter 1	Warning Symbol Definitions	1
Chapter 2	Safety	2
Chapter 3	Product Overview	3
	3.1. <i>Planck's Law and Black Body Radiation</i>	3
	3.2. <i>Tungsten Light Source</i>	4
	3.3. <i>Spectrum</i>	5
	3.4. <i>Optical Configuration</i>	5
	3.5. <i>Optional Collimator</i>	6
	3.6. <i>Output Stabilization</i>	7
Chapter 4	Operation	8
	4.1. <i>Part List</i>	8
	4.2. <i>Setting Up on a Working Surface</i>	8
	4.3. <i>Switching on the Light Source</i>	9
	4.4. <i>Filter Holder</i>	10
	4.5. <i>Front Fiber Coupler</i>	10
	4.6. <i>Adjusting Fiber Coupler Position</i>	11
	4.7. <i>Collimating Accessory (Optional)</i>	11
	4.8. <i>Application Ideas</i>	12
	4.9. <i>Bulb Module Replacement</i>	13
Chapter 5	Specifications	16
Chapter 6	Mechanical Drawing	17
Chapter 7	Certifications and Compliances	18
Chapter 8	Regulatory	19
Chapter 9	Thorlabs Worldwide Contacts	20

Chapter 1 Warning Symbol Definitions

Below is a list of warning symbols you may encounter in this manual or on your device.

Symbol	Description
	Direct Current
	Alternating Current
	Both Direct and Alternating Current
	Earth Ground Terminal
	Protective Conductor Terminal
	Frame or Chassis Terminal
	Equipotentiality
	On (Supply)
	Off (Supply)
	In Position of a Bi-Stable Push Control
	Out Position of a Bi-Stable Push Control
	Caution: Risk of Electric Shock
	Caution: Hot Surface
	Caution: Risk of Danger
	Warning: Laser Radiation
	Caution: Spinning Blades May Cause Harm

Chapter 2 Safety

The lamp comes with a switching power supply compatible with voltages from 100 to 240 VAC. There is no need to change the fuse.



WARNING



Do not operate this device in explosive environments.



WARNING



Do not operate this device in wet or damp conditions.



WARNING



Do NOT look directly at the light source beam during operation. Do NOT place hand or body part in the light beam as this may cause burning.



CAUTION: HOT SURFACE



The housing of the lamp housing can get very hot during operation. Extensive contact may cause burning.



WARNING: HOT SURFACE



The temperature of the bulb may reach a few hundred °C during operation. Always wait for at least 10 minutes for the bulb module to cool down before performing a bulb module replacement. Always wear gloves when handling bulb modules.

Chapter 3 Product Overview

3.1. Planck's Law and Black Body Radiation

A black body is an object that absorbs all incident electromagnetic radiation (e.g. light), no light passes through or is reflected. However, despite the name, a black body will also emit electromagnetic radiation. The radiation of a black body in thermal equilibrium is described by Planck's Law

$$I(\lambda, T) = \frac{2\pi hc^2}{\lambda^5} \frac{1}{e^{hc/\lambda kT} - 1}$$

Where I is the radiated power per unit area of emitting surface per unit wavelength at temperature T ; K is the Boltzmann constant, h is the Planck constant, and c is the speed of light.

By measuring the spectrum of the black body radiation, we can calculate the temperature of this black body. Figure.1 shows the radiated power per unit area I as a function of wavelength at various temperature.

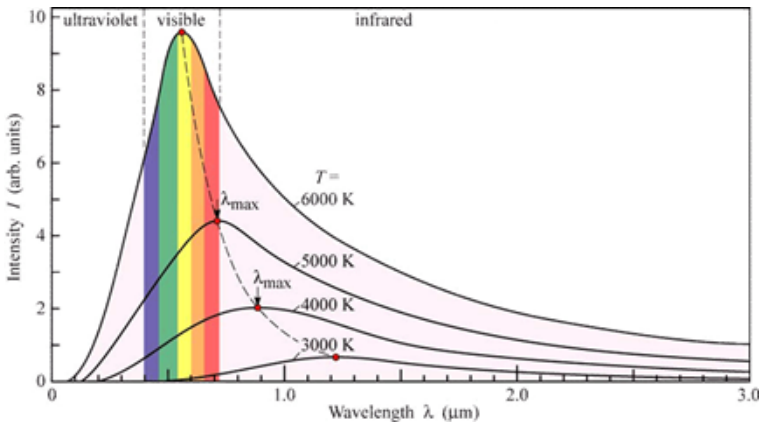

Figure 1 Black body radiation at different temperatures

In real life, broadband light sources may vary widely from the ideal black body in terms of the frequency and intensity of the light emitted. By comparing the light source to an ideal black body at a given temperature, one can characterize the light source by the temperature of the black body radiator which has the same chromaticity, which is known as the color temperature of the light source

3.2. Tungsten Light Source

A tungsten light source is a form of an incandescent lamp. During operation, a current flows through the Tungsten filament, which will heat up to around a couple of thousand Kelvin. Tungsten emits visible and infrared light at this temperature, creating a light source that can be approximated by a black body radiator.

SLS201L is a light source known as Quartz Tungsten Halogen (QTH) light sources. In such a light source, the Tungsten filament is sealed in a quartz envelope with inert gas and halogen mixture filled in the bulb. Tungsten atoms evaporated from the filament during operation will hit the gas atoms and then bounce back to the filament, thus lowering the overall rate of filament evaporation. The halogen in the gas mixture will also react with tungsten deposited on the inner surface of the bulb and form tungsten halide, which evaporates more easily back to the gas mixture. When tungsten halide gets near the filament, it dissociates at the high temperature of the filament, creating a gradient in the concentration of tungsten. Such flow is called the “tungsten-halogen cycle”. It effectively “pumps” the tungsten back to the filament, prolonging the life of the light source and reducing darkening of the bulb.

SLS202L is a Tungsten filament light source for IR applications. It operates at a lower color temperature thus generating more IR output. The filament is sealed behind a Sapphire window which transmits IR better than quartz. A gold reflector is also placed behind the filament which reflects the longer wavelength thus providing higher output in the NIR to MIR range.

Figure 2 shows the structure of the tungsten bulb used in SLS201L and SLS202L stabilized light sources. For SLS201L, the filament is sealed in a Quartz Envelope. For SLS202L, the filament is sealed in a cavity with a sapphire protective window on top of it. There is a gold reflector inside the cavity which reflects out all the IR light generated from the filament.

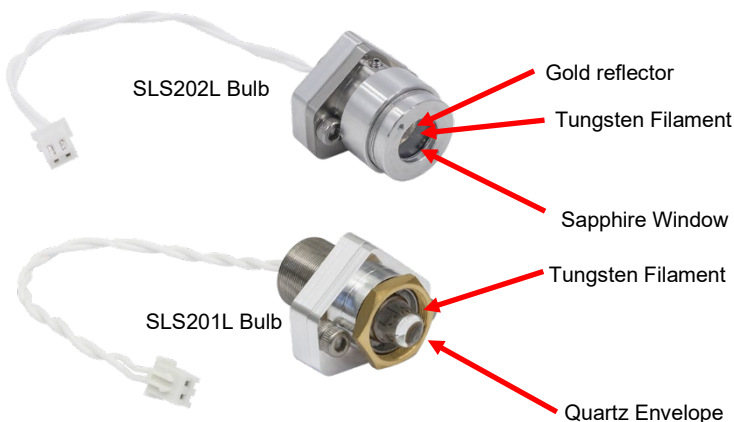

Figure 2 Structure of the Tungsten Halogen bulb used in SLS201L/SLS202L

3.3. Spectrum

The SLS201L tungsten halogen light source generates visible to IR output as far as 2600 nm, with a color temperature of 2796 K. The SLS202L generates output from 450 to 5500 nm with a color temperature of 1900 K. Figure 3 shows the typical output spectra of SLS201L and SLS202L compared to a theoretical black body spectrum at the corresponding temperature.

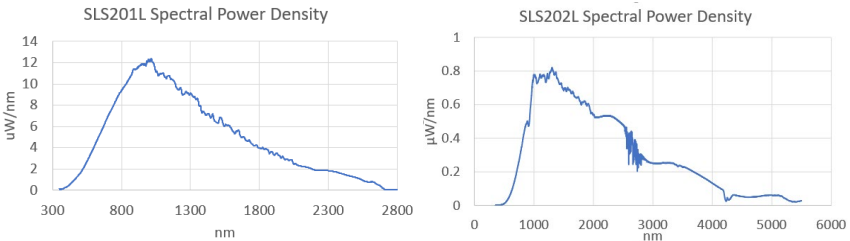

Figure 3 Typical Spectra

3.4. Optical Configuration

SLS201L/SLS202L are Tungsten Light Sources. The bulb is placed inside the housing, at the back focus of the 1st lens. The lens roughly collimates the output from the bulb and then a 2nd lens focuses the collimated beam into a multimode fiber patch cable, providing a fiber coupled broadband light source. Figure 4 shows the outline of beam path in SLS201L and SLS202L.

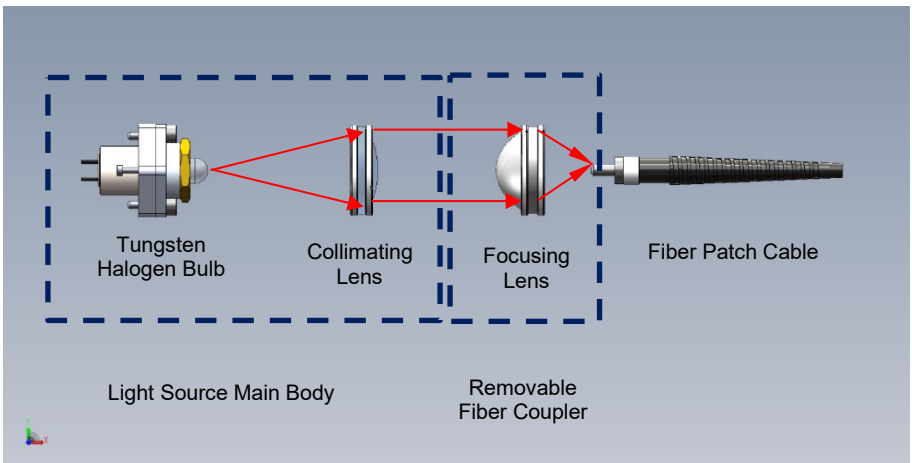

Figure 4 Basic Optical Configuration of SLS201L/SLS202L

The bulb and the collimating lens is located in the main body of the light source while the focusing lens is placed in a removable fiber coupler at the front the light

source main body. With the fiber coupler (focusing lens) removed, users can get access to the roughly collimated beam after the 1st lens.

The SLS201L/SLS202L features a quick release mechanism allowing users to easily remove and put back the fiber coupler, switching between a free space light source and a fiber coupled one.

3.5. Optional Collimator

Thorlabs also provides optional collimator (not included in the package) for SLS201L and SLS202L. As shown in Figure 5, the collimator works as an alternative to the fiber coupler. It utilizes the same focusing lens as in the fiber coupler to focus the roughly collimated beam from the 1st lens inside the light source main body into a 1mm pinhole. The pinhole cleans up the beam and then the beam is collimated again through a 3rd lens, giving a much better collimated free space beam output.

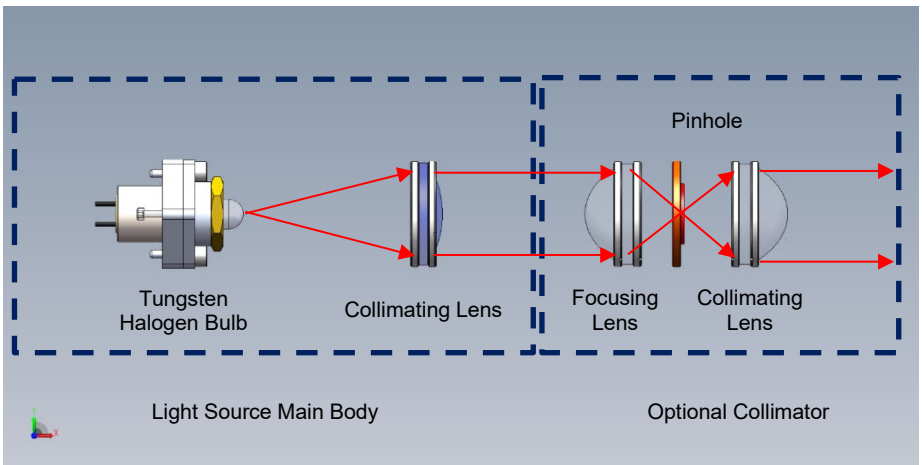

Figure 5 Optional Collimator of SLS201L/SLS202L

3.6. Output Stabilization

Unlike traditional filament based light sources, the SLS201L/SLS202L will not suffer either from a gradual decrease or short term fluctuation in brightness during its lifetime.

SLS201L/SLS202L light source is equipped with an internal feedback loop and therefore can ensure a constant intensity, low noise and long life span. The principle of operation is depicted in the block diagram below. The optical intensity is measured by an internal photodiode, which feeds its monitor signal to the controller unit. The controller unit then adjusts the driving current of the power supply to compensate any drift or fluctuation in the optical output.

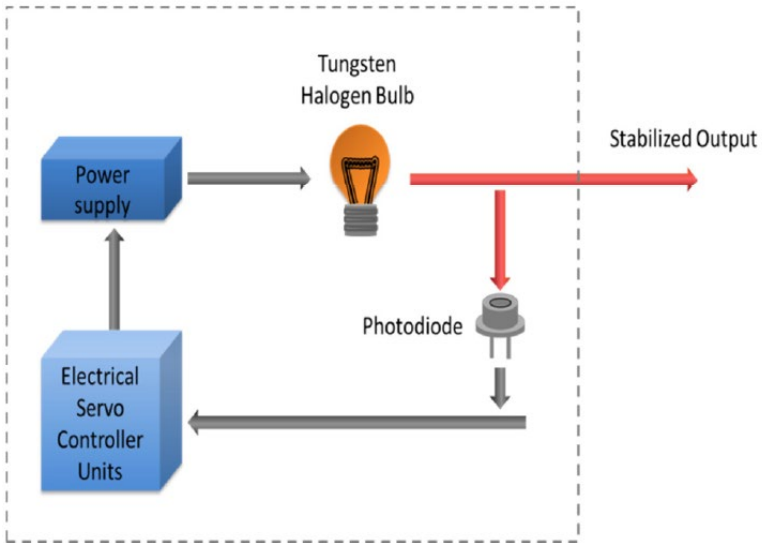

Figure 6 Closed Feedback Loop in SLS201L/SLS202L

Chapter 4 Operation

4.1. Part List

The package contains the following items:

1. SLS201L/SLS202L Light Source
2. DS12 12 V Power Supply
3. Power Cord
4. 1.3 mm (0.050") Hex Key
5. 1.5 mm Hex Key
6. 2 mm (5/64") Hex Key
7. 400 μ m core, 0.39NA Fiber Patch Cable (SLS201L only)
8. 30 mm Hex Wrench

4.2. Setting Up on a Working Surface

The light source has four non-adjustable plastic feet at the bottom so that it can be placed directly onto a flat working surfaces, as shown in Figure 7 (a). It also has two 1/4"-20 (M6) threaded mounting hole on the bottom, which are compatible with Thorlabs standard optical posts and post holders, enabling it to be mounted on a breadboard or optical as shown in Figure 7 (b).

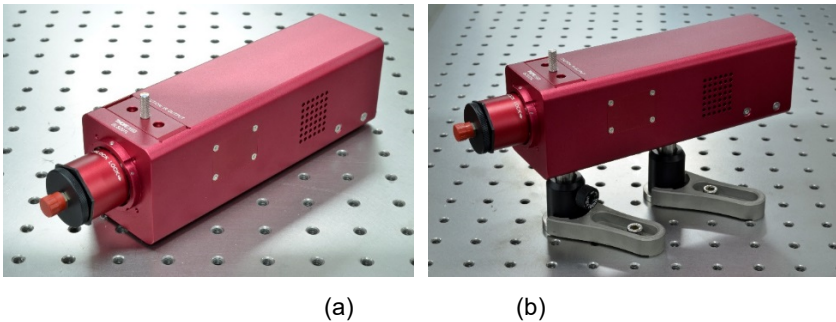

Figure 7 SLS201L Set Up on a Working Surface

4.3. Switching on the Light Source

After setting up the light source on a working surface, follow the steps below:



Figure 8 Switching on SLS201L/SLS202L

1. Connect the power supply to the 4-pin "Power In" plug on the back panel of the light source;
2. Rotate the threaded cap on the connector to lock it;
3. Flip the toggle switch to "I" to turn on the light source.

During normal operation, the green LED on the back panel will be lit. Please allow 45 minutes warm-up time for the light source to reach a stable state. Please notice that the cooling fan on the back panel works will only rotate after the interior of the light source reaches 65 °C. It is completely normal for the fan not to rotate during operations.



CAUTION: HOT SURFACE



The housing of the light source can get very hot during operation. The temperature may reach ~60 °C. Avoid extensive contact with skin.



WARNING



The light source generates high power IR output. Do NOT look directly at the light source beam during operation. Do NOT place hand or body part in the light beam as this may cause burning.

4.4. Filter Holder

The light source is equipped with a removable filter holder. The filter holder (filters sold separately) has an SM1 internal thread and one retaining ring. It allows the user to mount any Ø25 mm or Ø1" optics, the thickness of which is less than 8 mm, inside the light source.

The removable filter can be locked into place with the filter setscrew, located on the side of the stabilized light source. Use included 1.5 mm hex key to tighten/loosen the setscrew.



Figure 9 Removable Filter Holder of SLS201L

4.5. Front Fiber Coupler

The light source also features a fiber coupler at the output of the device. The fiber coupler has standard SMA connector for easy connection with SMA fiber patch cables. The fiber adapter is pre-adjusted to its optimum position before shipping out and does not require users to re-align in most circumstances.

The SLS201L/SLS202L features a quick release mechanism allowing users to easily install and remove the fiber coupler, switching between a free space light source and a fiber coupled one. The great mechanical repeatability of the quick release mechanism ensures that installing/removing the fiber coupler will not change its positioning relative to the bulb, thus ensuring a constant output power level.



Figure 10 Removable Front Lens Tube of SLS201L

As shown in Figure 10, the fiber coupler is installed onto the light source main body with a quick release blade mechanism and secured by a set screw. For free space applications, loosen the set screw with the included 0.050" (1.3 mm) hex key and turn the fiber coupler counterclockwise to unlock and remove the fiber coupler

After remove the fiber coupler, users can see the collimating lens in the light source and get access to a roughly collimated beam.

The SLS201L light source is shipped with a 1 m long, SMA to SMA fiber patch cable with below specs:

Core Diameter	NA	Cladding Diameter	Jacket	Bend Radius		Wavelength Range
				Short Term	Long Term	
400 ± 8 μm	0.39 ± 0.02	425 ± 10 μm	FT030 (Ø3 mm)	20 mm	40 mm	400 to 2200 nm (Low OH)

The SLS202L light source does not include any fiber patch cable, it is recommended to use with fluoride fibers which are also available on Thorlabs website: www.thorlabs.com

4.6. Adjusting Fiber Coupler Position

The fiber adapter is pre-adjusted to its optimum position before shipping out. But if really necessary, it is also allow users to do adjustment. As shown in below Figure 11, use the included 30 mm hex wrench to loosen the external retaining ring by turning it counterclockwise. Then rotate the SMA fiber adapter to adjust its position.



Figure 11 Adjust Fiber Adapter Position

4.7. Collimating Accessory (Optional)

Thorlabs also offer collimators for SLS201L and SLS202L separately as optional accessories for the light source. They are available on Thorlabs website: www.thorlabs.com

The collimator provides a well collimated beam but with a reduced power level. It also features the same quick release mechanism as in the standard fiber coupler, allowing quick and easy swap between the two different types of accessories.



Figure 12 Collimator Installed on SLS201L

4.8. Application Ideas

There are four 4-40 threaded holes on the front panel of the light source house to allow the integration of Thorlabs' 30 mm Cage System. The SM1 internal thread in the front lens tube also provides compatibility with Thorlabs' SM1 Lens Tubes and optical mounts.

Figure 13 illustrates how an SLS201L/SLS202L light source can be integrated with a 30 mm cage system and SM1 lens tube.



Figure 13 SLS201L/SLS202L with 30 mm Cage System and SM1 Lens Tube

4.9. Bulb Module Replacement



Warning



Always power off the unit before opening the housing.



Warning



The bulb surface temperature may reach a few hundred °C during operation. Always wait at least 10 minutes after turning off the lamp for cool down before performing a bulb module replacement.



Caution



Wear protective gloves when handling the bulb module. Moisture and grease from hands left on the bulb may shorten the bulb lifetime.



Warning



The electronics inside a light source are ESD sensitive. When performing a bulb module replacement, always wear ESD protection to avoid damaging the light source.

Thorlabs offers pre-aligned bulb replacement modules for SLS201L and SLS202L light source. The replacement modules are available on www.thorlabs.com under the SLS251 and SLS252 item numbers, respectively.

To replace the bulb module, place the light source upside down to reveal the underside of the unit. Using the included 5/64" (2 mm) hex key, remove the screw closest to the end of the unit from both the left and right sides. DO NOT remove the screws closest to the fan ventilation holes.



Figure 14 Remove the two screws at the rear of the light source.

Using the same 2 mm hex key, remove the four screws holding on the cavity cover.



Figure 15 Remove the four screws holding the cover.

Then using the 1.5 mm hex key included with the replacement bulb, remove the cap screw that locks the bulb module.



Figure 16 Loosen the bulb module locking screw.

Unplug the white plug that is connected to the bulb module. (It is located on the far side of the circuit board if the output aperture of the lamp is facing to the right.)



Figure 17 Unplug the bulb module connector.

Carefully pull out the old module by sliding the wire and attached plug out. Watch out for the PD signal wires when pulling out the old module since they may get in the way.



Figure 18 Pull out the bulb module.

Two aluminum dowel pins, located on either side of the bulb module, may slip out of their holes while the module is being removed. Be careful not to misplace them as they are needed for the new module installation.



Figure 19 Do not remove the dowel pins on the bulb module.

To install the new bulb module, place the two dowel pins in their corresponding holes in the new bulb module.

Slide the new bulb module in the bulb chamber. Pass the wire and plug through the hole in the central wall first and then insert the module. The two dowel pins should slide smoothly into the holes in the wall.

While pressing the bulb against the central wall, screw the cap screw back in using the included 1.5 mm hex key.

Insert the white plug back into the circuit board and secure the cavity cover.



Figure 20 Holes on the Central Wall for Bulb Dowel Pins

Chapter 5 Specifications

Specifications	SLS201L(/M)	SLS202L(/M)
Wavelength Range	360 – 2600 nm	450 – 5500 nm
Peak Wavelength ¹	1000 nm	1500 nm
Color Temperature	2796 K	1900 K
Color Temperature Stability	±15 K	
Bulb Power	9 W	7.2 W
Fiber Coupled Output Power (Typical)	10 mW ²	1.5 mW ³
Free Space Output Power (Typical) ⁴	500 mW	700 mW
Collimated Output Power (Typical) ⁵	60 mW	15 mW
Beam Divergence without Fiber Coupler ⁶	8.2°	13.8°
Collimated Beam Divergence ^{5,6}	2°	1.4°
Collimated Beam Diameter ^{5,7}	24 mm	10 mm
Output Power Drift per Hour (Typical)	0.01%	
Optical Power Drift per °C (Typical)	0.1%	
Output Power Stability ⁸	< 0.05%	
Power Supply	100 – 240 VAC	
Operating Temperature	0 to 45 °C	
Storage Temperature	-15 to 70 °C	
Dimension (L x W x H)	216.4 mm × 55.0 mm × 57.5 mm (8.52" × 2.17" × 2.26")	

¹ Theoretic Value based on Black Body Radiation.

² Measured with Included fiber patch cable at beginning of bulb lifetime.

³ Measured with Thorlabs MZ41L1 ZrF₄ MIR patch cable at the beginning of bulb lifetime.

⁴ Measured at the output port of the light source with fiber coupler removed.

⁵ Measured with optional collimator accessory.

⁶ Half Angle, Design Value @ 587 nm

⁷ Measured 10 cm away from the collimating lens.

⁸ Standard deviation of optical power value in percentage, measured at room temperature over a 1 hour period with 1 Hz sampling rate after 45 minutes warm-up.

Chapter 6 Mechanical Drawing

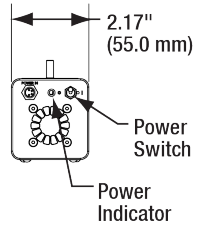
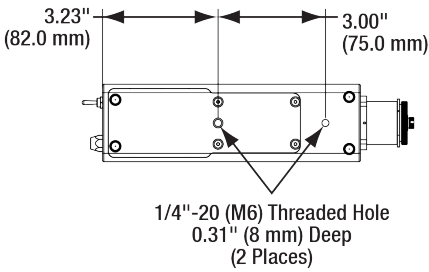
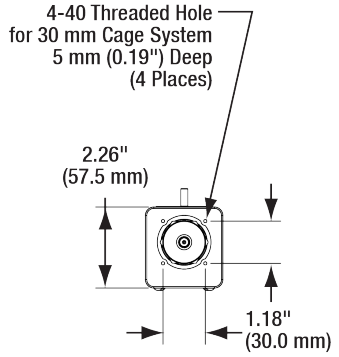
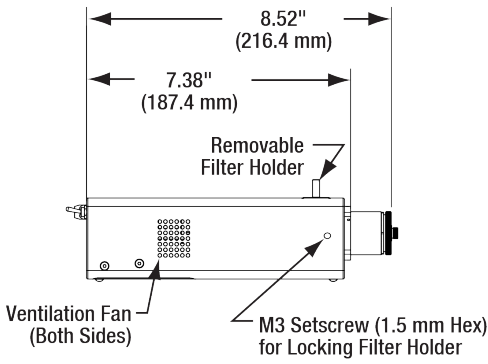

Chapter 7 Certifications and Compliances



Declaration of Conformity

We: Thorlabs Optical Electronic Technology (Shanghai) Co., Ltd
of: Room A101, No.100, Lane 2891, South Qilianshan Rd, Shanghai

In accordance with the following directive(s):

2014/35/EU	Low Voltage Directive (LVD)
2014/30/EU	Electromagnetic Compatibility (EMC) Directive
2011/65/EU	RoHS 2 Directive
2009/125/EC	Ecodesign Directive

hereby declare that:

Model: **SLS201L, SLS201L/M, SLS202L, SLS202L/M, SLS203L, SLS203L/M**
Equipment: **Stabilized Broadband Light Source**

Is in conformity with the applicable requirements of the following documents:

EN 61010-1:2010
EN 61326-1:2013
EN 62471:2008 (Exempt Group)

and which, issued under the sole responsibility of Thorlabs, is in conformity with Directive 2011/65/EU of the European Parliament and of the Council of 8th June 2011 on the restriction of the use of certain hazardous substances in electrical and electronic equipment, for the reason stated below:

does not contain substances in excess of the maximum concentration values tolerated by weight in homogenous materials as listed in Annex II of the Directive.

I hereby declare that the equipment named has been designed to comply with the relevant section of the above referenced specifications, and complies with all applicable Essential Requirements of the Directives.

Signed:

on: 8. May 2017

Name: Shanshan Song
Position: General Manager

This device complies with Part 15 of the FCC Rules. Operation is subject to the following two conditions:

- (1) this device may not cause harmful interference, and
- (2) this device must accept any interference received, including interference that may cause undesired operation.

Chapter 8 Regulatory

As required by the WEEE (Waste Electrical and Electronic Equipment Directive) of the European Community and the corresponding national laws, Thorlabs offers all end users in the EC the possibility to return “end of life” units without incurring disposal charges.

- This offer is valid for Thorlabs electrical and electronic equipment:
- Sold after August 13, 2005
- Marked correspondingly with the crossed out “wheelie bin” logo (see right)
- Sold to a company or institute within the EC
- Currently owned by a company or institute within the EC
- Still complete, not disassembled and not contaminated

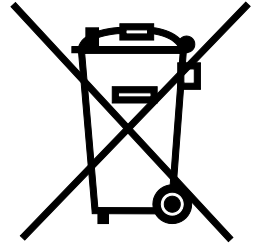

As the WEEE directive applies to self-contained operational electrical and electronic products, this end of life take back service does not refer to other Thorlabs products, such as:

- Pure OEM products, that means assemblies to be built into a unit by the user (e.g. OEM laser driver cards)
- Components
- Mechanics and optics
- Left over parts of units disassembled by the user (PCB's, housings etc.).

If you wish to return a Thorlabs unit for waste recovery, please contact Thorlabs or your nearest dealer for further information.

Waste Treatment is Your Own Responsibility

If you do not return an “end of life” unit to Thorlabs, you must hand it to a company specialized in waste recovery. Do not dispose of the unit in a litter bin or at a public waste disposal site.

Ecological Background

It is well known that WEEE pollutes the environment by releasing toxic products during decomposition. The aim of the European RoHS directive is to reduce the content of toxic substances in electronic products in the future.

The intent of the WEEE directive is to enforce the recycling of WEEE. A controlled recycling of end of life products will thereby avoid negative impacts on the environment.

Chapter 9 Thorlabs Worldwide Contacts

For technical support or sales inquiries, please visit us at www.thorlabs.com/contact for our most up-to-date contact information.



USA, Canada, and South America

Thorlabs, Inc.
sales@thorlabs.com
techsupport@thorlabs.com

Europe

Thorlabs GmbH
europe@thorlabs.com

France

Thorlabs SAS
sales.fr@thorlabs.com

Japan

Thorlabs Japan, Inc.
sales@thorlabs.jp

UK and Ireland

Thorlabs Ltd.
sales.uk@thorlabs.com
techsupport.uk@thorlabs.com

Scandinavia

Thorlabs Sweden AB
scandinavia@thorlabs.com

Brazil

Thorlabs Vendas de Fotônicos Ltda.
brasil@thorlabs.com

China

Thorlabs China
chinasales@thorlabs.com



THORLABS

www.thorlabs.com
